

VLG-23M.I

Technical Data

 Art. No.
11143093

Digital Monochrome Matrix Camera, IP65/67, Gigabit Ethernet

Sensor Information

Model Name	Sony IMX174
Type	1/1.2" progressive scan CMOS
Shutter	Global
Native Resolution	1920 x 1200 pixels
Scan Area	11.25 mm x 7.03 mm
Pixel Size	5.86 μm x 5.86 μm

Data Quality

@ 20 °C, gain = 1, exposure time = 32 msec

Readout Noise (σ)	0.06 LSB @ 8 bit, 1 LSB @ 12 bit (typical)
Dynamic Range	73 dB (typical)

Acquisition Formats

Image Formats	Format	Resolution	Frame Rate	t_{readout}
	Full Frame	1920 x 1200	53 fps ¹	15.5 msec
Pixel Formats	Mono8, Mono12, Mono12 Packed			
Partial Scan	True Partial Scan, Region of Interest (ROI) arbitrary			

Image Pre-Processing

Analog Controls	Exposure Time (45 μsec ... 60 sec Step Size 1 μsec) Gain (0 ... 48 dB), Offset (0 ... 255 LSB 12 bit),
Gamma Correction	Gamma (0.1 ... 2 available if LUT is enabled)
LUT	Luminance (12 bit)
Color Models	Mono
Color Tolerance	Only on Color Cameras
Color Processing	Only on Color Cameras
Color Adjustment	Only on Color Cameras
Binning Horizontal	1 or 2 ²
Binning Vertical	1 or 2 ²
Image Flipping	Horizontal, vertical
Defect Pixel Correction	via Defect Pixel List with up to 511 Pixel Coordinates

Process Synchronization

Modes	Free Running, Trigger
Free Running	Continuous or Adjustable Acquisition Frame Rate (0.01 ... 1703 Hz)
Trigger Sources	Hardware, Software, ActionCommand, All or Off
Trigger Delay	0 ... 2 sec, Tracking and buffering of up to 256 triggers
Sequencer Characteristics	up to 128 sets of parameters, up to 65536 loop passes, up to 65536 repetitions of sets of parameters, up to 65536 images per trigger event
Sequencer Parameters	Exposure Time, Gain Factor, Output Line, ROI Offset x, ROI offset y
External Flash Sync	via Exposure Active $t_{\text{delay flash}} \leq 3 \mu\text{sec}$, $t_{\text{duration}} = t_{\text{exposure}}$

Digital I/Os

Lines	Input: Line 0, Output: Line1, Line 2, Line 3
Circuit Times	Output: $t_{\text{ON}} = \text{typ. } 3 \mu\text{sec}$ $t_{\text{OFF}} = \text{typ. } 40 \mu\text{sec}$
Output Sources	Off, ExposureActive, Line 0, Timer1 ... 3, ReadoutActive, User0 ... 2, TriggerReady, TriggerOverlapped, TriggerSkipped, Sequencer Output 0 ... 2
Line Debouncer	Low and high signal separately selectable Debouncing Time 0 ... 5 msec, Step Size: 1 μsec

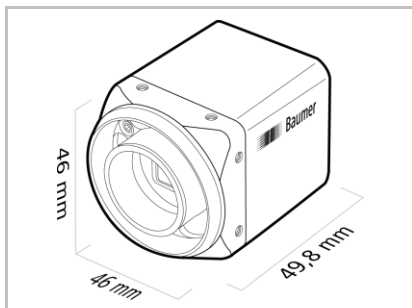

Sensor Graph: Relative Response

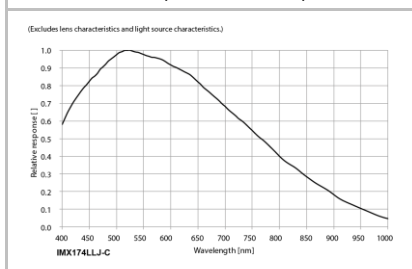
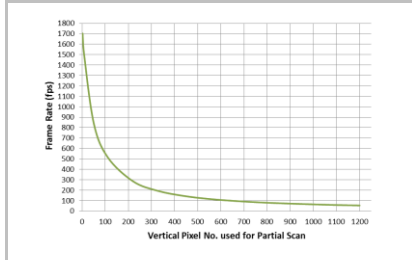
 Frame Rates / Partial Scan
(Measured at Mono8/BayerRGB-Format)

Digital Output: High Active

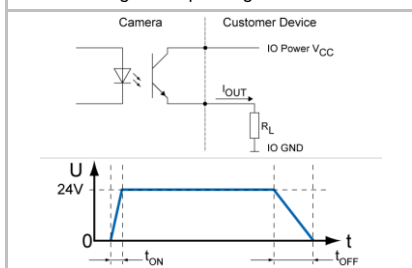
¹ limited frame rate depend on used interface board

² Binning calculated on camera (no higher frame rate) – Sensor do not support binning operation

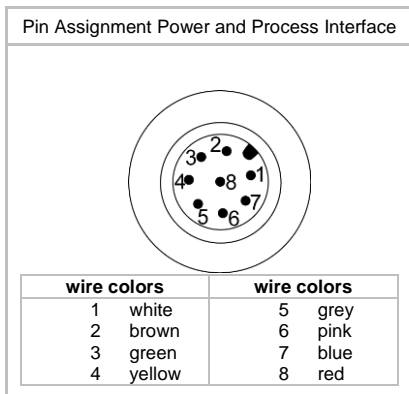
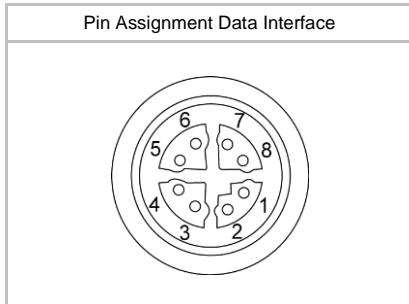
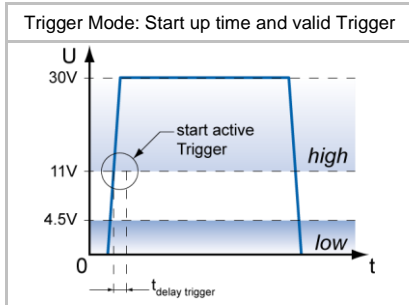
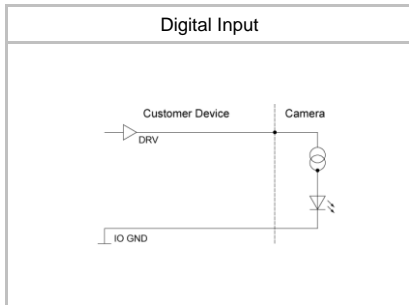
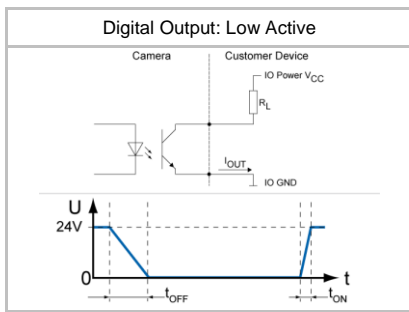

Interfaces and Connectors

Data Interface	Gigabit Ethernet	Transfer Rate	1000 Mbits/sec
	Fast Ethernet	Transfer Rate	100 Mbits/sec
	Connector:	8P8C Modular Jack (RJ45) screw lock type	
	Pin Assignment:	1 – MX1+	5 – MX3-
		2 – MX1-	6 – MX2-
		3 – MX2+	7 – MX4+
		4 – MX3+	8 – MX4-
Power Interface	Connector:	SACC-DSI-M 8MS-6CON-L180 SH	
	Assignment:	1 – Power VCC	4 – OUT 1
		2 – IN1	5 – IO Power VCC
		3 – GND	6 – IO GND
Process Interface	Connector:	SACC-DSI-M8FS-3CON-M10-L180 SH	
	Assignment:	1 – not used	
		3 – OUT2	
		4 – OUT3	

Mechanical Data

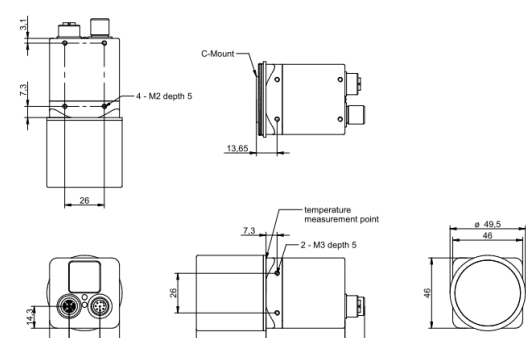
Housing	Aluminium, IP65/67
Dimensions	

Weight	185 g (220g incl. Tube)
--------	-------------------------

Optical Data

Lens Mount	C-Mount
Optical Filter	Dust Protection Glass

Electrical Data

Power Supply (ext.)	VCC: 12 ... 24 V DC \pm 20%
	I: 145 ... 273mA
Power over Ethernet	Class 0 device
	VCC: 36 ... 57 V DC
	I: 79 mA @ 48 VDC
Power Consumption	approx. 3.5 W @ 12 VDC and 53 fps
	approx. 3.8 W @ 48 VDC (PoE) and 53 fps
Digital Input	$U_{IN(low)}$: 0.0 ... 4.5 VDC
	$U_{IN(high)}$: 11.0 ... 30.0 VDC
	I_{IN} : 6.0 ... 10 mA
	min. Impulse Length: 2.0 μ sec
	Trigger Delay out of treadout: 2.6 μ sec
	max. Trigger Delay during treadout: 12.3 μ sec
Digital Output	U_{EXT} : 5 ... 30 V DC
	I_{OUT} : max. 50 mA

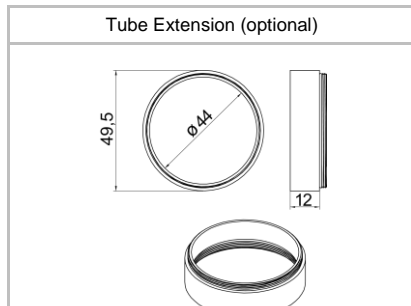
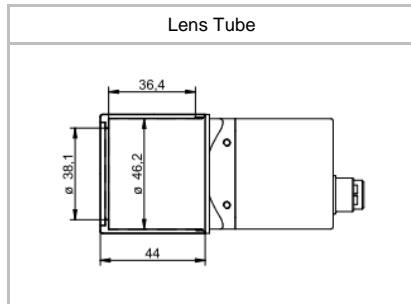
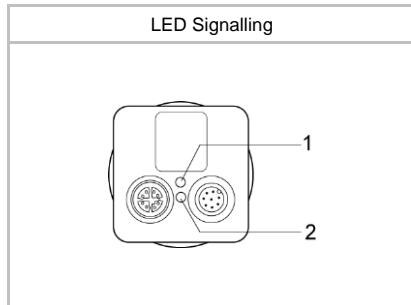
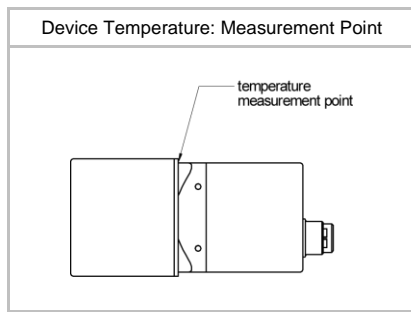

Art. No.: 11089149



LED Signalling

LED 1 (top)	Green	Link active
	Green flash	Receiving
LED 2 (bottom)	Yellow	Transmitting

Environmental Data

Storage Temperature	-10 °C bis +70 °C	
Operating Temperature	+5°C ... +50°C	
Device Temperature	T _{max} = 50 °C @ Measurement Point	
Humidity	10 % ... 90 % non-condensing	
Conformity	RoHs, REACH, CE	

Network Interface Data

Network Interface	Gigabit Ethernet	1000BASE-T	1000 Mbits/sec
	Fast Ethernet	100 BASE-T	100 Mbits/sec
Ethernet IP Configuration	Persistent IP, DHCP, LLA		
Packet Size	576 ... 16 KByte, Jumbo Frames supported		

GigE Vision® Features (in compliance with GigE Vision® 1.2)

Events Transmission via Asynchronous Message Channel	PrimaryApplicationStitch, GigEVisionError, GigEVisionHeartbeatTimeOut, EventLost, EventDiscarded, Line0RisingEdge, Line0FallingEdge, Line1RisingEdge, Line1FallingEdge, Line2RisingEdge, Line2FallingEdge, Line3RisingEdge, Line3FallingEdge, ExposureStart, ExposureEnd, FrameStart, FrameEnd, TriggerReady, TriggerOverlapped, TriggerSkipped		
Frame Counter	up to 2 ³²		
Payload Size	4 ... 4.608.272 Byte		
Transmission Delay	0 .. 2 ³² -1 Ticks (1 Tick = 1 nsec)		
Timestamp	64 bit		
Packet Delay	0 .. 2 ³² -1 Ticks		
Packet Resend	Resend Buffer:	120 MB (13 Images)	

GenICam™ Features (in compliance with SFNC 1.5.1)

Timer	Timer Selector: Timer 1 ... 3 TimerTriggerSource: Line0, SoftwareTrigger, CommandTrigger, ExposureStart, ExposureEnd, FrameStart, FrameEnd, TriggerSkipped, Off TimerDelay: 0 µsec ... 2 sec, Step Size: 1 µsec TimerDuration: 10 µsec ... 2 sec, Step Size: 1 µsec		
User Sets	Factory Settings:	UserSet0 (read only)	
	Freely Programmable:	UserSet1, UserSet2, UserSet3	
	Parameters:	any user definable Parameter	
Acquisition Abort	Delay up to 15.5 msec		

Vendor Specific Features

FPN Correction	no
HDR	no

Factory Settings after Start-Up

Operation Mode	Free Running
Analog Controls	Exposure Time: 15 msec, Gain: 0 dB, Offset: 0
Pixel Format	Mono8
Partial Scan	Off
Acquisition Frame Rate	Off
Timer	Off
Transmission Delay	Off
Defect Pixel Correction	On
FPN Correction	-
Digital Input	Line0, invert = false, trigger source = All
Digital Output	Line1, invert = false, line source = Off