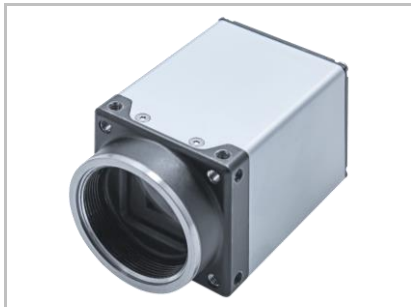

# VLG-03M.CS

## Technical Data

 Art. No.  
11163336

### Digital Monochrome Matrix Camera, Gigabit Ethernet

#### Sensor Information

Model Name	CMOSIS CMV-300
Type	1/3" progressive scan CMOS
Shutter	global
Native Resolution	640 x 480 pixels
Scan Area	4.74 mm x 3.55 mm
Pixel Size	7.4 μm x 7.4 μm

#### Data Quality

@ 20 °C, gain = 1, exposure time = 32 msec

Readout Noise	$\sigma < 0.5$ LSB (8 bit) typical
Dynamic Range	typical > 55 dB

#### Acquisition Formats

Image Formats	Format	Resolution	Frame Rate	t <sub>readout</sub>
	Full Frame	640 x 480	376 fps	2.65 msec
Pixel Formats	Mono8, Mono12, Mono12 Packed			
Partial Scan	True Partial Scan, Region of Interest (ROI) arbitrary			

#### Image Pre-Processing

Analog Controls	Exposure Time (15 μsec ... 1 sec   Step Size 1 μsec) Gain (0 ... 18 dB), Offset (0 ... 255 LSB   12 bit),
Gamma Correction	Gamma (0.1 ... 2   available if LUT is enabled)
LUT	Luminance (12 bit)
Color Models	Mono
Color Tolerance	Only on Color Cameras
Color Processing	Only on Color Cameras
Color Adjustment	Only on Color Cameras
Binning Horizontal	1 or 2
Binning Vertical	1 or 2
Image Flipping	Horizontal, vertical
Defect Pixel Correction	via Defect Pixel List with up to 511 Pixel Coordinates

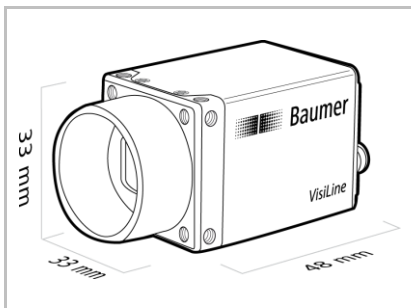

Sensor Graph: Relative Response



Digital Output: High Active

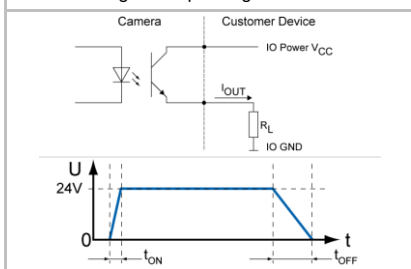

Digital Output: Low Active

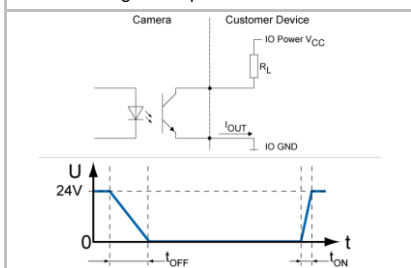

#### Process Synchronization

Modes	Free Running, Trigger
Free Running	Continuous or Adjustable Acquisition Frame Rate (0 ... 5914 Hz)
Trigger Sources	Hardware, Software, ActionCommand, All or Off
Trigger Delay	0 ... 2 sec, Tracking and buffering of up to 512 triggers
Sequencer Characteristics	up to 128 sets of parameters, up to 65536 loop passes, up to 65536 repetitions of sets of parameters, up to 65536 images per trigger event
Sequencer Parameters	Exposure Time, Gain Factor, Output Line, ROI Offset x, ROI offset y
External Flash Sync	via Exposure Active t <sub>delay flash</sub> ≤ 3 μsec, t <sub>duration</sub> = t <sub>exposure</sub>

#### Digital I/Os

Lines	Input: Line 0, Output: Line1, Line 2, Line 3
Circuit Times	Output: t <sub>ON</sub> = typ. 3 μsec t <sub>OFF</sub> = typ. 40 μsec
Output Sources	Off, ExposureActive, Line 0, Timer1 ... 3, ReadoutActive, User0 ... 2, TriggerReady, TriggerOverlapped, TriggerSkipped, Sequencer Output 0 ... 2
Line Debouncer	Low and high signal separately selectable Debouncing Time 0 ... 5 msec, Step Size: 1 μsec

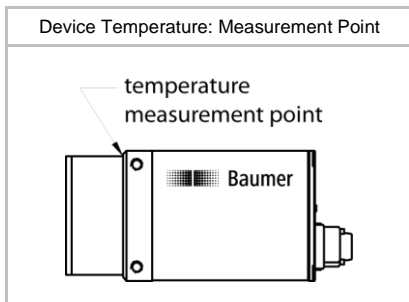
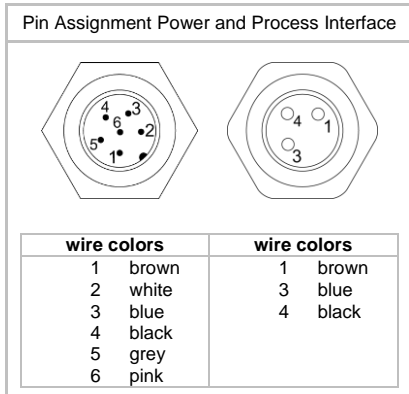
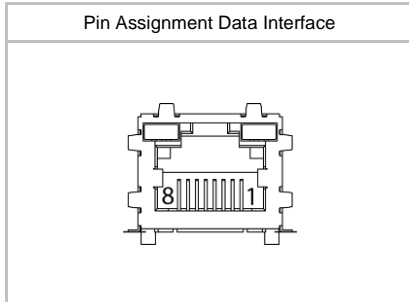
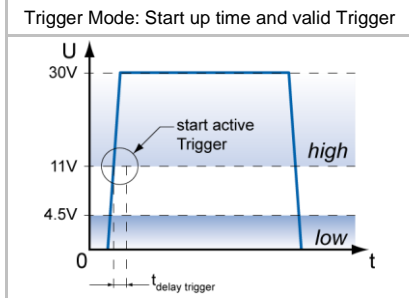
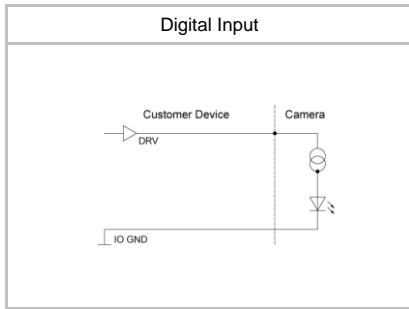
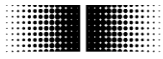

## Interfaces and Connectors

<b>Data Interface</b>	Gigabit Ethernet Fast Ethernet Connector: Pin Assignment:	Transfer Rate 1000 Mbits/sec Transfer Rate 100 Mbits/sec 8P8C Modular Jack (RJ45) screw lock type 1 – MX1+      5 – MX3- 2 – MX1-      6 – MX2- 3 – MX2+      7 – MX4+ 4 – MX3+      8 – MX4-
<b>Power Interface</b>	Connector: Assignment:	SACC-DSI-M 8MS-6CON-L180 SH 1 – Power VCC      4 – OUT 1 2 – IN1              5 – IO Power VCC 3 – GND             6 – IO GND
<b>Process Interface</b>	Connector: Assignment:	SACC-DSI-M8FS-3CON-M10-L180 SH 1 – not used 3 – OUT2 4 – OUT3

## Mechanical Data

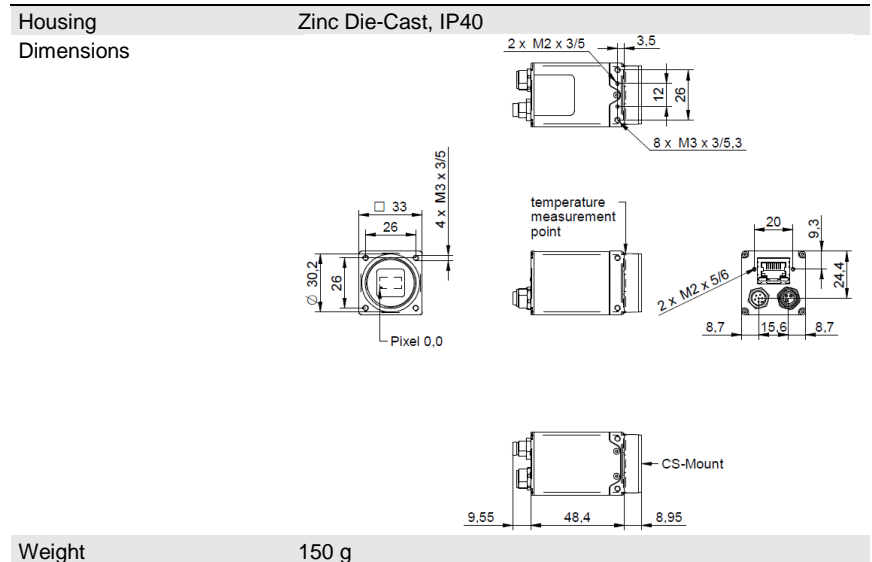

<b>Weight</b>	150 g
---------------	-------

## Optical Data

<b>Lens Mount</b>	C-Mount
<b>Optical Filter</b>	Dust Protection Glass

## Electrical Data

<b>Power Supply (ext.)</b>	VCC: 12 ... 24 V DC $\pm$ 20% I: 130 ... 250mA
<b>Power over Ethernet</b>	Class 0 device VCC: 36 ... 57 V DC I: 75 mA @ 48 VDC
<b>Power Consumption</b>	approx. 3.0 W @ 12 VDC and 376 fps approx. 3.6 W @ 48 VDC (PoE) and 376 fps
<b>Digital Input</b>	$U_{IN(low)}$ : 0.0 ... 4.5 VDC $U_{IN(high)}$ : 11.0 ... 30.0 VDC $I_{IN}$ : 6.0 ... 10 mA min. Impulse Length: 2.0 $\mu$ sec Trigger Delay out of <i>treadout</i> : 1.0 $\mu$ sec max. Trigger Delay during <i>treadout</i> : 14.0 $\mu$ sec
<b>Digital Output</b>	$U_{EXT}$ : 5 ... 30 V DC $I_{OUT}$ : max. 50 mA

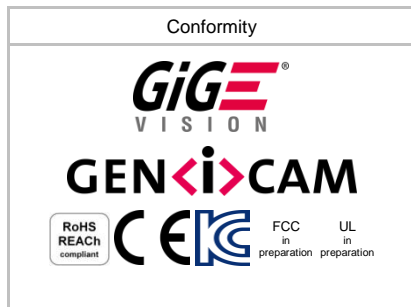
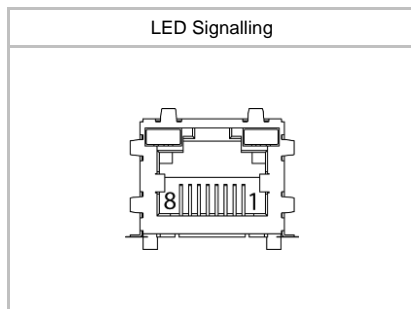

### LED Signalling

LED 1 (right)	Green	Link active
	Green flash	Receiving
LED 2 (left)	Yellow	Transmitting

### Environmental Data

Storage Temperature	-10 °C bis +70 °C	
Operating Temperature	+5°C ... +50°C	
Device Temperature	T <sub>max</sub> = 50 °C @ Measurement Point	
Humidity	10 % ... 90 % non-condensing	
Conformity	RoHs, REACH, CE	
KC Registration No. / Date	MSIP-REI-BkR-VLG-03MCS / 15.09.2017	

### Network Interface Data

Network Interface	Gigabit Ethernet	1000BASE-T	1000 Mbits/sec
	Fast Ethernet	100 BASE-T	100 Mbits/sec
Ethernet IP Configuration	Persistent IP, DHCP, LLA		
Packet Size	576 ... 16 KByte, Jumbo Frames supported		

### GigE Vision® Features (in compliance with GigE Vision® 1.2)

Events Transmission via Asynchronous Message Channel	PrimaryApplicationStitch, GigEVisionError, GigEVisionHeartbeatTimeOut, EventLost, EventDiscarded, Line0RisingEdge, Line0FallingEdge, Line1RisingEdge, Line1FallingEdge, Line2RisingEdge, Line2FallingEdge, Line3RisingEdge, Line3FallingEdge, ExposureStart, ExposureEnd, FrameStart, FrameEnd, TriggerReady, TriggerOverlapped, TriggerSkipped	
Frame Counter	up to 2 <sup>32</sup>	
Payload Size	4 ... 4.431.664Byte	
Transmission Delay	0 .. 2 <sup>32</sup> -1 Ticks (1 Tick = 1 nsec)	
Timestamp	64 bit	
Packet Delay	0 .. 2 <sup>32</sup> -1 Ticks	
Packet Resend	Resend Buffer:	120 MB (15 Images)

### GenICam™ Features (in compliance with SFNC 1.5.1)

Timer	Timer Selector: Timer 1 ... 3 TimerTriggerSource: Line0, SoftwareTrigger, CommandTrigger, ExposureStart, ExposureEnd, FrameStart, FrameEnd, TriggerSkipped, Off TimerDelay: 0 µsec ... 2 sec, Step Size: 1 µsec TimerDuration: 10 µsec ... 2 sec, Step Size: 1 µsec	
User Sets	Factory Settings:	UserSet0 (read only)
	Freely Programmable:	UserSet1, UserSet2, UserSet3
	Parameters:	any user definable Parameter
Acquisition Abort	Delay up to 37 msec	

### Factory Settings after Start-Up

Operation Mode	Free Running
Analog Controls	Exposure Time: 4 msec, Gain: 0 dB, Offset: 0
Pixel Format	Mono8
Partial Scan	Off
Acquisition Frame Rate	Off
Timer	Off
Transmission Delay	Off
Defect Pixel Correction	On
Digital Input	Line0, invert = false, trigger source = All
Digital Output	Line1, invert = false, line source = Off