

VLG-02C

Technical Data

 Art. No.
11094927

Digital Color Matrix Camera, Gigabit Ethernet

Sensor Information

Model Name	SONY ICX618
Type	1/4" progressive scan CCD, EXview HAD technology
Shutter	Global
Native Resolution	656 x 490 pixels
Scan Area	3.67 mm x 2.74 mm
Pixel Size	5.6 μm x 5.6 μm

Data Quality

@ 20 °C, gain = 1, exposure time = 32 msec

Readout Noise (σ)	0.2 LSB @ 8 bit, 3.5 LSB @ 12 bit (typical)
Dynamic Range	61 dB (typical)

Acquisition Formats

Image Formats	Format	Resolution	Frame Rate	t_{readout}
	Full Frame	656 x 490	160 fps	6.25 msec
Pixel Formats	Mono8, BayerRG8, BayerRG12, RGB8 Packed, BGR8Packed, YUV411Packed, YUV422Packed, YUV444Packed			
Partial Scan	True Partial Scan, Region of Interest (ROI) arbitrary			

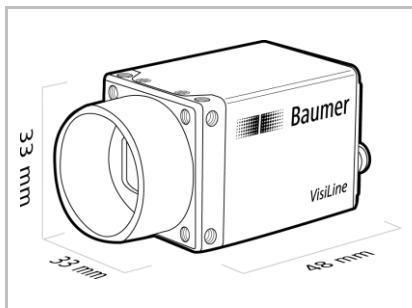

Sensor Graph: Relative Response

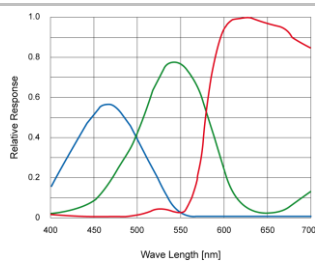
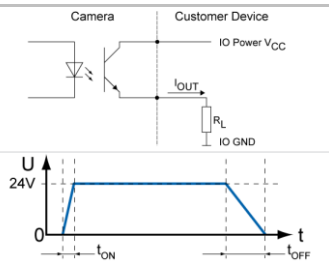

Image Pre-Processing

Analog Controls	Exposure Time (4 μsec ... 60 sec Step Size 1 μsec) Gain (0 ... 29 dB), Offset (0 ... 1023 LSB 14 bit),
Gamma Correction	Gamma (0.1 ... 2 available if LUT is enabled)
LUT	Luminance (12 bit)
Color Models	RGB, YUV, Mono
Color Tolerance	0,6 % (typical)
Color Processing	Integrated color processor for high quality color calculation
Color Adjustment	White Balance (manual & one push)
Binning Horizontal	1 or 2 (true color binning)
Binning Vertical	1 or 2 (true color binning)
Image Flipping	Horizontal
Defect Pixel Correction	via Defect Pixel List with up to 511 Pixel Coordinates

Digital Output: High Active



Digital Output: Low Active

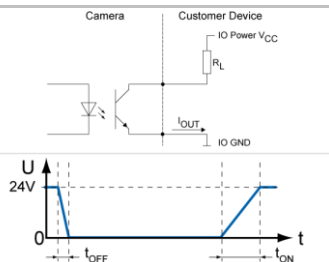

Process Synchronization

Modes	Free Running, Trigger
Free Running	Continuous or Adjustable Acquisition Frame Rate ¹ (0.01 ... 1072 Hz)
Trigger Sources	Hardware, Software, ActionCommand, All or Off
Trigger Delay	0 ... 2 sec, Tracking and buffering of up to 512 triggers
Sequencer Characteristics	up to 128 sets of parameters, up to 65536 loop passes, up to 65536 repetitions of sets of parameters, up to 65536 images per trigger event
Sequencer Parameters	Exposure Time, Gain Factor, Output Line, ROI Offset x, ROI Offset y
External Flash Sync	via Exposure Active $t_{\text{delay flash}} \leq 3 \mu\text{sec}$, $t_{\text{duration}} = t_{\text{exposure}}$

Digital I/Os

Lines	Input: Line 0, Output: Line1, Line 2, Line 3
Circuit Times	Output: $t_{\text{ON}} = \text{typ. } 3 \mu\text{sec}$ $t_{\text{OFF}} = \text{typ. } 40 \mu\text{sec}$
Output Sources	Off, ExposureActive, Line 0, Timer1 ... 3, ReadoutActive, User0 ... 2, TriggerReady, TriggerOverlapped, TriggerSkipped, Sequencer Output 0 ... 2
Line Debouncer	Low and high signal separately selectable Debouncing Time 0 ... 5 msec, Step Size: 1 μsec

¹ Max. Acquisition Frame Rate can be achieved by using the following camera settings: min. Exposure + max. Binning + ROI | min. Size Y + Mono8

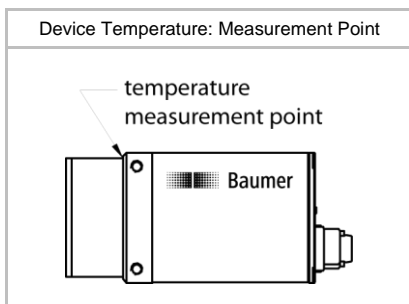
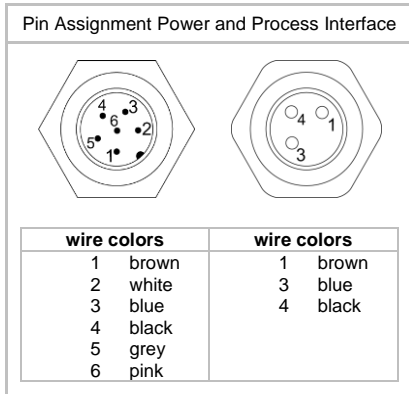
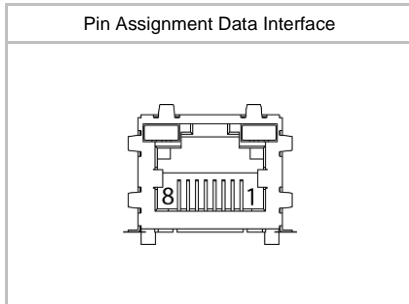
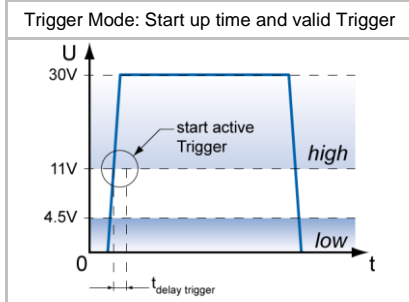
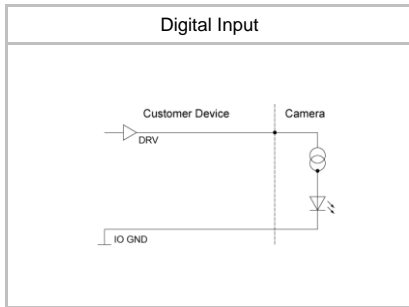

Interfaces and Connectors

Data Interface	Gigabit Ethernet	Transfer Rate	1000 Mbits/sec
	Fast Ethernet	Transfer Rate	100 Mbits/sec
	Connector:	8P8C Modular Jack (RJ45) screw lock type	
	Pin Assignment:	1 – MX1+	5 – MX3-
		2 – MX1-	6 – MX2-
		3 – MX2+	7 – MX4+
		4 – MX3+	8 – MX4-
Power Interface	Connector:	SACC-DSI-M 8MS-6CON-L180 SH	
	Assignment:	1 – Power VCC	4 – OUT 1
		2 – IN1	5 – IO Power VCC
		3 – GND	6 – IO GND
Process Interface	Connector:	SACC-DSI-M8FS-3CON-M10-L180 SH	
	Assignment:	1 – not used	
		3 – OUT2	
		4 – OUT3	

Mechanical Data

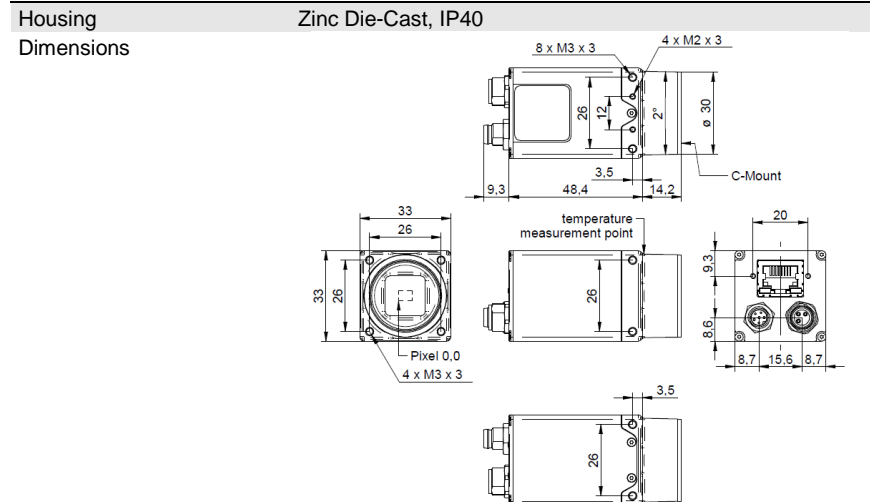

Weight	150 g
--------	-------

Optical Data

Lens Mount	C-Mount
Optical Filter	IR-Cut Filter

Electrical Data

Power Supply (ext.)	VCC:	12 ... 24 V DC ± 20%
	I:	139 ... 269 mA
Power over Ethernet	Class 0 device	
	VCC:	36 ... 57 V DC
	I:	77 mA @ 48 VDC
Power Consumption	approx.	3.4 W @ 12 VDC and 160 fps
	approx.	3.7 W @ 48 VDC (PoE) and 160 fps
Digital Input	$U_{IN(low)}$:	0.0 ... 4.5 VDC
	$U_{IN(high)}$:	11.0 ... 30.0 VDC
	I_{IN} :	6.0 ... 10 mA
	min. Impulse Length:	2.0 µsec
	Trigger Delay out of treadout:	1.0 µsec
	max. Trigger Delay during treadout:	14.0 µsec
Digital Output	U_{EXT} :	5 ... 30 V DC
	I_{OUT} :	max. 50 mA

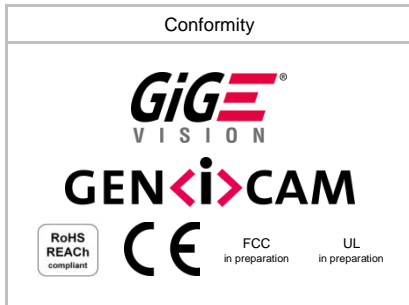
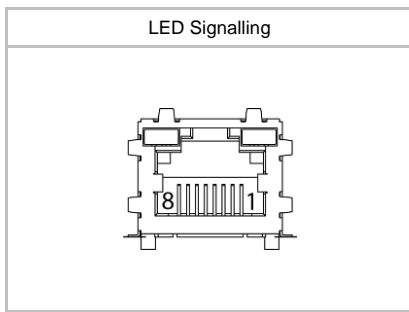

LED Signalling

LED 1 (right)	Green	Link active
	Green flash	Receiving
LED 2 (left)	Yellow	Transmitting

Environmental Data

Storage Temperature	-10 °C bis +70 °C
Operating Temperature	+5°C ... +50°C
Device Temperature	T _{max} = 50 °C @ Measurement Point
Humidity	10 % ... 90 % non-condensing
Conformity	RoHs, REACH, CE

Network Interface Data

Network Interface	Gigabit Ethernet	1000BASE-T	1000 Mbits/sec
	Fast Ethernet	100 BASE-T	100 Mbits/sec
Ethernet IP Configuration	Persistent IP, DHCP, LLA		
Packet Size	576 ... 16 KByte, Jumbo Frames supported		

GigE Vision® Features (in compliance with GigE Vision® 1.2)

Events Transmission via Asynchronous Message Channel	PrimaryApplicationStitch, GigEVisionError, GigEVisionHeartbeatTimeOut, EventLost, EventDiscarded, Line0RisingEdge, Line0FallingEdge, Line1RisingEdge, Line1FallingEdge, Line2RisingEdge, Line2FallingEdge, Line3RisingEdge, Line3FallingEdge, ExposureStart, ExposureEnd, FrameStart, FrameEnd, TriggerReady, TriggerOverlapped, TriggerSkipped	
Frame Counter	up to 2 ³²	
Payload Size	4 ... 643.152 Byte	
Transmission Delay	0 .. 2 ³² -1 Ticks (1 Tick = 1 nsec)	
Timestamp	64 bit	
Packet Delay	0 .. 2 ³² -1 Ticks	
Packet Resend	Resend Buffer:	120 MB (30 Images)

GeniCam™ Features (in compliance with SFNC 1.5.1)

Timer	Timer Selector: Timer 1 ... 3 TimerTriggerSource: Line0, SoftwareTrigger, CommandTrigger, ExposureStart, ExposureEnd, FrameStart, FrameEnd, TriggerSkipped, Off TimerDelay: 0 µsec ... 2 sec, Step Size: 1 µsec TimerDuration: 10 µsec ... 2 sec, Step Size: 1 µsec	
User Sets	Factory Settings:	UserSet0 (read only)
	Freely Programmable:	UserSet1, UserSet2, UserSet3
	Parameters:	any user definable Parameter
Acquisition Abort	Delay up to 6.3 msec	

Factory Settings after Start-Up

Operation Mode	Free Running
Analog Controls	Exposure Time: 4 msec, Gain: 0 dB, Offset: 0
Pixel Format	BayerRG8
Partial Scan	Off
Acquisition Frame Rate	Off
Timer	Off
Transmission Delay	Off
Defect Pixel Correction	On
Digital Input	Line0, invert = false, trigger source = All
Digital Output	Line1, invert = false, line source = Off