

Sensor Information

Model Name	Sony IMX290
Type	1/2.8" progressive scan CMOS
Shutter	Rolling Shutter, Global Reset Shutter
Resolution	1920 x 1080 pixels
Scan Area	5.56 mm x 3.13 mm
Pixel Size	2.9 μm x 2.9 μm

Data Quality

@ 20 °C, gain = 1, exposure time = 4 msec

Dark Noise (σ)	3 e- typical
Saturation	14000 e- typical
Dynamic Range	71 dB typical
SNR	41 dB typical
Quantum efficiency η	83 % @ 536 nm typical

Acquisition

Resolution	1920 px x 1080 px		
Interface Frame Rate (depends on used interface performance)	Format	Resolution	max. Frame Rate (@ Trigger Mode) ²⁾
	Full Frame	1920 x 1080	58 fps
	Binning 2x2	960 x 540	89 fps
	Binning 2x1	960 x 1080	58 fps
	Binning 1x2	1920 x 540	89 fps
Acquisition Frame Rate ¹⁾ (Burst Mode)	89 fps $t_{readout} = 11.2$ msec (max. Res. Full Frame) @ 10 bit		
	60 fps $t_{readout} = 16.7$ msec (max. Res. Full Frame) @ 12 bit		
Pixel Formats	Mono8, Mono10, Mono12, Mono12p		
Partial Scan	True Partial Scan with increasing Frame Rate on Y direction, Region of Interest (ROI) arbitrary		
	Width: minimum 32, increment 32		
	Height: minimum 2, increment 2		
Adjustable Acquisition Frame Rate	Off or Off or 0.39 ... 65535 Hz		
Acquisition Mode	Continuous, Single Frame and Multi Frame		
Acquisition Status	AcquisitionActive, AcquisitionTrigger Wait		
Exposure Mode	Timed		
Readout Mode	not available		

Image Pre-Processing

Analog Controls	Exposure Time (15 μsec ... 60 sec Step Size 1 μsec) Gain (0...48 dB), Offset (0 ... 255 LSB 12 bit)
Auto Function	ExposureAuto and GainAuto with BrightnessAutoPriority based on BrightnessAuto ROI
LUT	Luminance (12 bit)
Color Models	Mono
Color Processing	-
Color Adjustment	-
Color Enhancement	-
Color Tolerance	-

¹⁾ Sensor readout, different from pixel format

²⁾ depends on the used interface

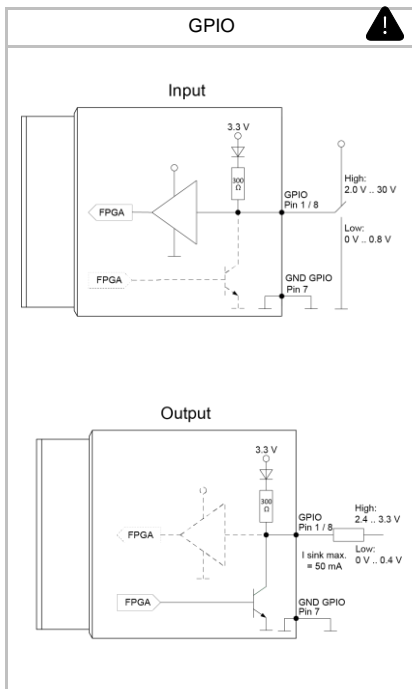
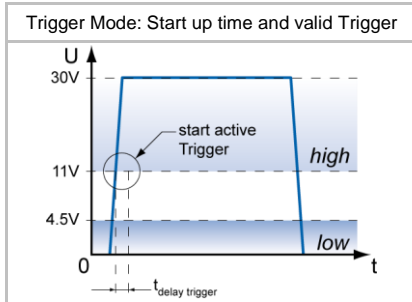
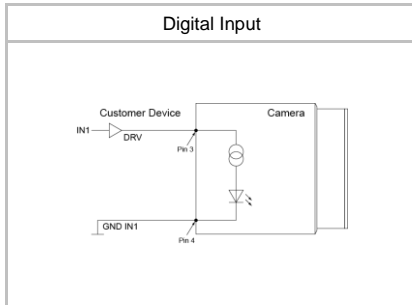
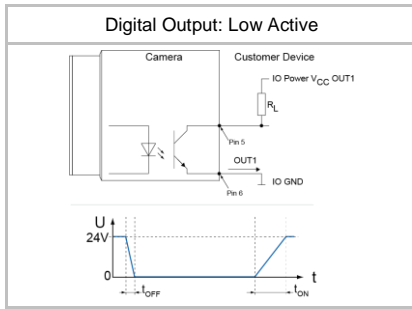

¹⁾ Sensor readout, different from pixel format

Image Pre-Processing

Binning Horizontal	1 or 2
Binning Vertical	1 or 2
Image Flipping	no
Defect Pixel Correction	via Defect Pixel List with up to 512 Pixel Coordinates
Fix Pattern Noise Correction	-

Process Synchronization

Trigger Mode	Off (Free Running), On (Trigger)
Trigger Overlap Type	Trigger Mode On: Off Trigger Mode Off: Not available
Trigger Sources	Hardware (Line0, 1, 2), Software, Counter 1, 2 End, Action CMD (Action 1), All or Off max. Trigger Delay out of t _{readout} : ¹⁾ 11124 μsec / 10 μsec @ 10 bit (Rolling / Global Reset) 16603 μsec / 14.9 μsec @ 12 bit (Rolling / Global Reset) max. Trigger Delay during t _{readout} : ¹⁾ -
Trigger Delay	0 ... 2 sec, Tracking and buffering of up to 256 triggers
External Flash Sync	via Exposure Active t _{delay flash} ≤ 3 μsec, t _{duration} = t _{exposure}
Encoder Function	-
PTP Function	-

Digital I/Os

Lines	Input: Line 0, Output: Line3, GPIO: Line 1, Line 2
Output Sources	Off, ExposureActive, Timer1, ReadoutActive, UserOutput 1-3 and TriggerReady
Line Debouncer	Low and high signal separately selectable Debouncing Time 0 ... 5 msec, Step Size: 1 μsec

Memory

Image Buffer	95 MB 16 Images (Trigger Mode) / 1 Image (Free Running Mode)
Non-volatile Memory	128 kb

Network Interface Data

Interface	Gigabit Ethernet 1000BASE-T 1000 Mbits/sec Fast Ethernet 100 BASE-T 100 Mbits/sec
Ethernet IP Configuration	Persistent IP, DHCP, LLA
Packet Size	576 ... 9000 Byte, Jumbo Frames supported

GigE Vision® Features

Events	DeviceTemperatureStatusChanged, EventLost, ExposureEnd, ExposureStart, FrameEnd, FrameStart, FrameTransferSkipped, GigEVisionError, GigEVisionHeartbeatTimeOut, PrimaryApplicationSwitch, Line0..2 FallingEdge, Line0..2 RisingEdge, TransferBufferFull, TransferBufferReady, TriggerOverlapped, TriggerReady, TriggerSkipped
Transmission via Asynchronous Message Channel	yes, Action 1 for Trigger
Action CMD	yes, Action 1 for Trigger
Frame Counter	up to 2 ³²
Payload Size	0 ... 4147412 Byte
Timestamp	64 bit, resolution in nsec, increment = 8
Packet Delay	0 .. 2 ³² - 1 nsec
Packet Resend	Resend Buffer: 64 MB (16 Images)
GigE Vision	v2.0 (v1.2 backward compatible)

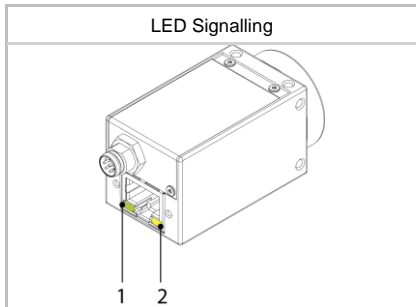
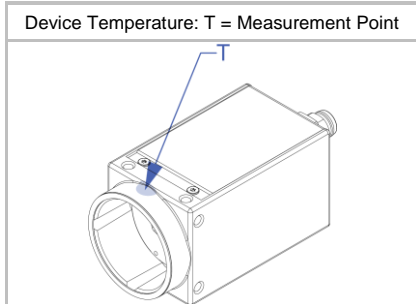
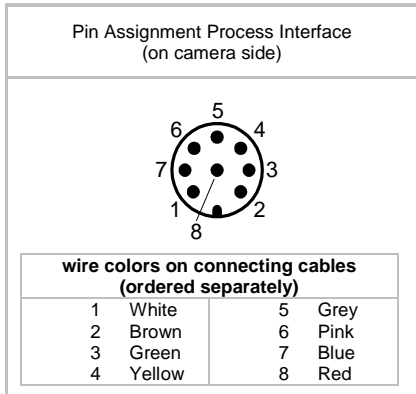
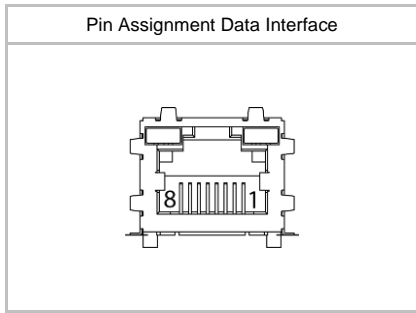

Interfaces and Connectors

Data and Power Interface	Gigabit Ethernet	Transfer Rate	1000 Mbits/sec
	Fast Ethernet	Transfer Rate	100 Mbits/sec
	Connector:	8P8C Modular Jack (RJ45), screw lock type	
Process Interface	Connector:	M8/8-pin (SACC-DSI-M8MS-8CON-M8-L180)	
	Assignment:	1 - MX1+	2 - MX1-
		3 - MX2+	4 - MX3+
		5 - MX3-	6 - MX2-
		7 - MX4+	8 - MX4-
		Assignment:	1 - GPIO (Line2)
		3 - IN1 (Line0)	4 - GND IN1
		5 - Power VCC OUT	6 - OUT1 (Line3)
		7 - GND (Power, GPIO)	8 - GPIO (Line1)

Caution



* Note GPIOs: Ground loops are to be avoided and can lead to destruction of the device.

Optical Data

Lens Mount	C-Mount
Optical Filter	-

Mechanical Data

Housing	Zinc die casting, baked varnish (until 02-2020 nickel-chrome-plated)
Protection Class	IP40 (with mounted lens and GigE cable)
Weight	120 g
Dimensions	

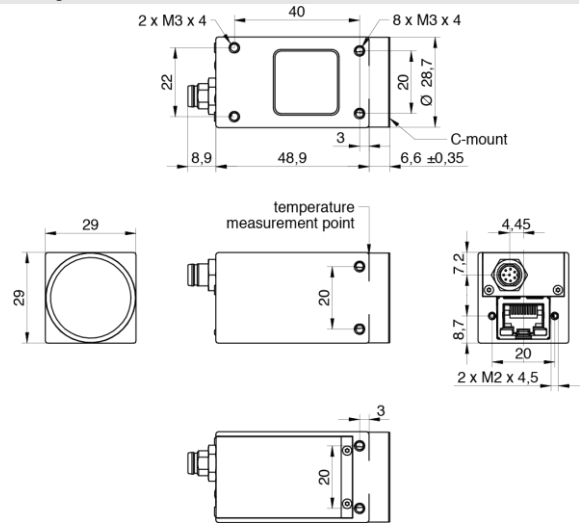

Environmental Data

Storage Temperature	-10 °C ... +70 °C
Operating Temperature	+5 °C ... +65 °C @ T = Measurement Point or *) +5 °C ... +72 °C @ internal Temperature Sensor
	Ambient temperature above 37 °C requires heat dissipation measures.
Int. Temperature	yes, accuracy:
Sensor	±1 °C (typ) 0 °C ... +85 °C
Humidity	10 % ... 90 % non-condensing

*) the maximum temperature for Sony sensor characteristics (sensor performance) are guaranteed up to 54°C @ Measurement Point or 60°C @ internal temperature sensor

LED Signalling

LED	LED 1	Green static	Link ON
		Green flash	RX active
LED 2	LED 2	Yellow static	Error
		Yellow flash	TX active

Electrical Data

Power Supply (ext.)	VCC: 12 ... 24 V DC \pm 20% I: 79 ... 159 mA
Power over Ethernet	Class 1 device VCC: 36 ... 57 V DC I: 50 mA @ 48 VDC
Power Consumption	approx. 1.9 W @ 12VDC and 58 fps approx. 2.4 W @ 48 VDC (PoE) and 58 fps (Factory Setting "Default")
Digital Input	Optocoupler $U_{IN(low)}$: 0.0 ... 4.5 VDC $U_{IN(high)}$: 11.0 ... 30.0 VDC I_{IN} : 3.0 ... 10.0 mA min. Impulse Length: 2.0 μ sec
Digital Output	Optocoupler U_{EXT} : 5 ... 30 V DC I_{OUT} : max. 50 mA t_{ON} = typ. 3 μ sec t_{OFF} = typ. 40 μ sec
GPIO	direct, without optocoupler
GPIO used as Input:	$U_{IN(low)}$: 0.0 ... 0.8 VDC $U_{IN(high)}$: 2.0 ... 30.0 VDC min. Impulse Length: 2.0 μ sec
GPIO used as Output:	$U_{Out(low)}$: 0.0 ... 0.4 VDC ($I_{sink\ max}$: 50 mA) $U_{Out(high)}$: 2.4 ... 3.3VDC (I_{max} : 1 mA)
Caution 	* The General Purpose I/Os (GPIOs) are not potential-free and do not have an overrun cut-off. Incorrect wiring (overvoltage, undervoltage or voltage reversal) can lead to defects in the electronic system. Ground loops are to be avoided and can lead to destruction of the device.

Conformity

Conformity	CE, RoHS, REACH
KC Registration No. / Date	- / -
MTBF	60 years @ T = 45 °C / 39 years @ T = 60 °C T = Measurement Point

GenICam™ Features

Short Exposure Range	-
Timer	Timer Selector: Timer 1 TimerTriggerSource: Line0, SoftwareTrigger, ExposureStart, ExposureEnd, FrameTransferSkipped, TriggerSkipped, Action 1 and Off TimerDelay: 0 μ sec ... 2 sec, Step Size: 1 μ sec TimerDuration: 4 μ sec ... 2 sec, Step Size: 1 μ sec
Counter	Counter Selector: Counter 1, Counter 2 CounterValue: 0 ... 65535 Counter Event Source: Counter1End or Counter2End, ExposureActive, FrameTransferSkipped, FrameTrigger, TriggerSkipped, Line0..2 and Off Counter Reset Source: Counter1End, Counter2End, Line0..2 and Off
Sequencer	no

GenICam™ Features

User Sets	Factory Settings: UserSet0 (read only) Freely Programmable: UserSet1, UserSet2, UserSet3 Parameters: any user definable Parameter
Acquisition Abort	Delay up to 16.7 msec
Chunk Data	yes, Chunk Selector: Binning, BlackLevel, CounterValue, DeviceTemperature, ExposureTime, FrameID, Gain, Height, Image, ImageControl, LineStatusAll, OffsetX, OffsetY, PixelFormat, , Timestamp, Width
Device Temperature	InHouse Event generation for Normal to High, High to Exceeded and Exceeded to Normal Exceeded (no image transfer) = max. internal temperature sensor + 1 °C
Device Link Throughput Limit	yes, up to max. Device Link Speed
Custom Data	yes, 128 Byte
SFNC Version	v2.4

Factory Settings after Start-Up

Ethernet IP Configuration	
Trigger Mode	Off (Free Running)
Analog Controls	Exposure Time: 4 msec, Gain: 0 dB, Offset: 0
Pixel Format	Mono8
Partial Scan	Off
Acquisition Frame Rate	Off
Timer/Counter/Sequencer	Off
Defect Pixel Correction	ON
Fixed Pattern Noise Correction	-
Digital Input	Line0, invert = false
Digital Output	Line3, invert = false, line source = Off
GPIO 1/2	Line1, Line2, invert = false, LineMode = Input
TriggerSource	All

Partial Scan @ FullFrame, min Exposure, Mono8 (monochrome camera) or BayerRG8 (color camera)

	Resolution	max. fps acquisition	max. fps interface ²⁾
Full HD	1920 x 1080	58,5	58,5
SXGA	1280 x 1024	91,8	91,8
HD720	1280 x 720	129,7	129,7
XGA	1024 x 768	124,7	124,7
SVGA	800 x 600	157,5	157,5
VGA	640 x 480	194,4	194,4
CIF	352 x 288	296,9	296,9
QVGA	320 x 240	297,0	297,0
QCIF	176 x 144	-	-
LineScan	1920 x 1024	61,7	61,7
	1920 x 512	121,3	121,3
	1920 x 256	234,9	234,9
	1920 x 128	296,9	296,9
	1920 x 64	296,9	296,9
	1920 x 32	296,9	296,9
	1920 x 16	296,9	296,9
	1920 x 8	297,0	297,0
	1920 x 4	296,9	296,9
	1920 x 2	297,0	297,0
	1920 x 1	-	-

²⁾ depends on the used interface