

## Sensor Information

Model Name	Sony IMX304
Type	1.1" progressive scan CMOS
Shutter	Global Shutter
Resolution	4096 x 3000 pixels
Scan Area	14.13 mm x 10.35 mm
Pixel Size	3.45 $\mu\text{m}$ x 3.45 $\mu\text{m}$

## Data Quality

@ 20 °C, gain = 1, exposure time = 4 msec

Dark Noise ( $\sigma$ )	2 e- typical
Saturation	9500 e- typical
Dynamic Range	71 dB typical
SNR	40 dB typical
Quantum efficiency $\eta$	47 % @ 465 nm, 58 % @ 536 nm, 53 % @ 631 nm typical

## Acquisition

Resolution	4096 px x 3000 px		
Interface Frame Rate (depends on used interface performance)	Format	Resolution	max. Frame Rate (@ Trigger Mode) <sup>2)</sup>
	Full Frame	4096 x 3000	9 fps
	Binning 2x2	2048 x 1500	15 fps
	Binning 2x1	2048 x 3000	15 fps
	Binning 1x2	4096 x 1500	15 fps
Acquisition Frame Rate <sup>1)</sup> (Burst Mode)	15 fps   $t_{\text{readout}} = 65.9 \text{ msec}$ (max. Res. Full Frame) @ 12 bit		

**Pixel Formats**  
BayerRG8, BayerRG10, BayerRG12, BayerRG12p  
Mono8, Mono10, Mono12, Mono12p, RGB8, BGR8

**Partial Scan**  
True Partial Scan with increasing Frame Rate on Y direction, Region of Interest (ROI) arbitrary

Width: minimum 16, increment 16  
Height: minimum 2, increment 2

**Adjustable Acquisition Frame Rate**  
Off or Off or 0.01 ... 65535 Hz

**Acquisition Mode**  
Continuous, Single Frame and Multi Frame

**Acquisition Status**  
AcquisitionActive, AcquisitionTrigger Wait

**Exposure Mode**  
Timed

**Readout Mode**  
Overlapped, Sequential

## Image Pre-Processing

**Analog Controls**  
Exposure Time (1  $\mu\text{sec}$  ... 60 sec | Step Size 1  $\mu\text{sec}$ )  
Gain (0...48 dB), Offset (0 ... 255 LSB | 12 bit)

**Auto Function**  
BalanceWhiteAuto based on FullFrame

**LUT**  
Luminance (12 bit)

**Color Models**  
Mono, Raw Bayer, RGB and BGR

**Color Processing**  
Integrated color processor for high quality color calculation

**Color Adjustment**  
Manual White Balance  
Automatic White Balance (Once or Continuous) based on Region of Interest (ROI)

**Color Enhancement**  
Color Transformation to sRGB color space by optimized Matrix for 3000 K, 5000 K, 6500 K and 9500 K  
Lightsource or User defined Matrix

**Color Tolerance**  
-

<sup>1)</sup> Sensor readout, different from pixel format

<sup>2)</sup> depends on the used interface

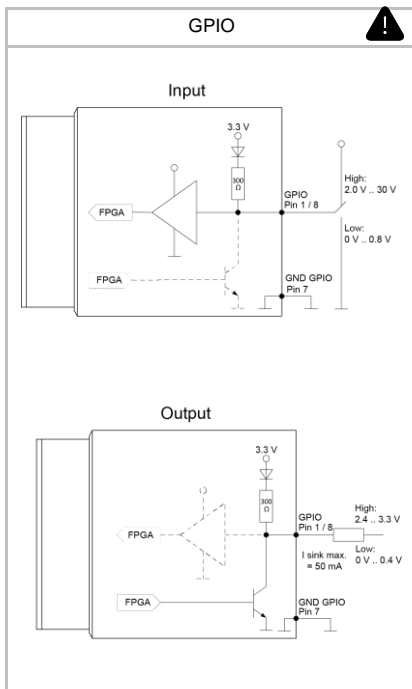
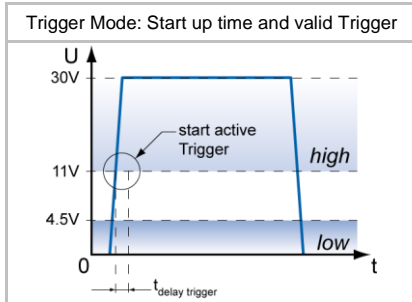
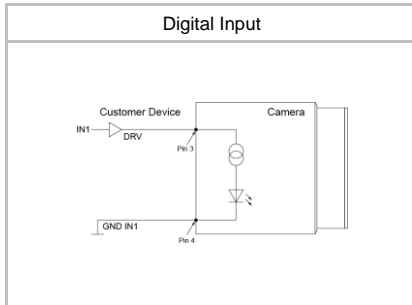
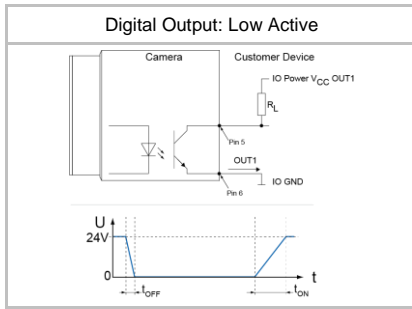

<sup>1)</sup> Sensor readout, different from pixel format

## Image Pre-Processing

Binning Horizontal	1 or 2
Binning Vertical	1 or 2
Image Flipping	Horizontal, vertical
Defect Pixel Correction	via Defect Pixel List with up to 512 Pixel Coordinates
Fix Pattern Noise Correction	-

## Process Synchronization

Trigger Mode	Off (Free Running), On (Trigger)
Trigger Overlap Type	Readout
Trigger Sources	Hardware (Line0, 1, 2), Software, Counter 1, 2 End, Action CMD (Action 1), All or Off fixed Trigger Delay out of $t_{readout}$ : <sup>1)</sup> 97.7 $\mu\text{sec}$ @ 12 bit max. Trigger Delay during $t_{readout}$ : <sup>1)</sup> 114.1 $\mu\text{sec}$ @ 12 bit
Trigger Delay	0 ... 2 sec, Tracking and buffering of up to 128 triggers
External Flash Sync	via Exposure Active $t_{delay\ flash} \leq 3\ \mu\text{sec}$ , $t_{duration} = t_{exposure}$
Encoder Function	yes, via Counter and Trigger Source
PTP Function	yes, Master or Slave (IEEE 1588)

## Digital I/Os

Lines	Input: Line 0, Output: Line3, GPIO: Line 1, Line 2
Output Sources	Off, ExposureActive, Timer1, ReadoutActive, UserOutput 1-3 and TriggerReady
Line Debouncer	Low and high signal separately selectable Debouncing Time 0 ... 5 msec, Step Size: 1 $\mu\text{sec}$

## Memory

Image Buffer	36 MB 1 Images (Trigger Mode) / 1 Image (Free Running Mode)
Non-volatile Memory	128 kb

## Network Interface Data

Interface	Gigabit Ethernet 1000BASE-T 1000 Mbits/sec Fast Ethernet 100 BASE-T 100 Mbits/sec
Ethernet IP Configuration	Persistent IP, DHCP, LLA
Packet Size	576 ... 9000 Byte, Jumbo Frames supported

## GigE Vision® Features

Events Transmission via Asynchronous Message Channel	DeviceTemperatureStatusChanged, EventLost, ExposureEnd, ExposureStart, FrameEnd, FrameStart, FrameTransferSkipped, GigE VisionError, GigE VisionHeartbeatTimeout, PrimaryApplicationSwitch, Line0..2 FallingEdge, Line0..2 RisingEdge, TransferBufferFull, TransferBufferReady, TriggerOverlapped, TriggerReady, TriggerSkipped, PtpServoStatusChanged, PtpStatusChanged
Action CMD	yes, Action 1 for Trigger
Frame Counter	up to 2 <sup>32</sup>
Payload Size	0 ... 36864240 Byte
Timestamp	64 bit, resolution in nsec, increment = 8
Packet Delay	0 .. 2 <sup>32</sup> - 1 nsec
Packet Resend	Resend Buffer: 71 MB (2 Images)
GigE Vision	v2.0

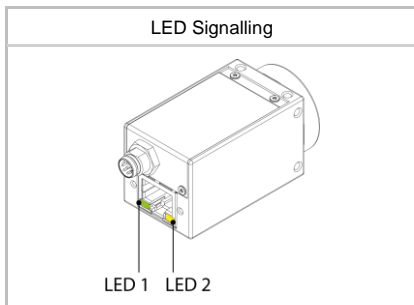
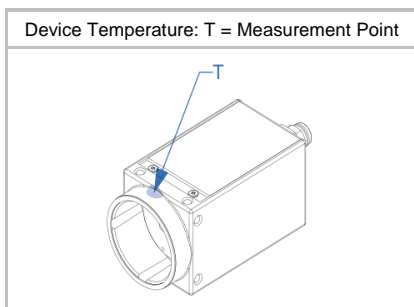
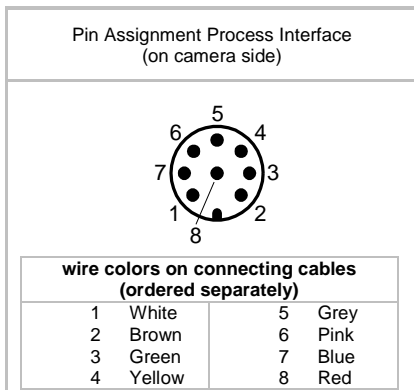
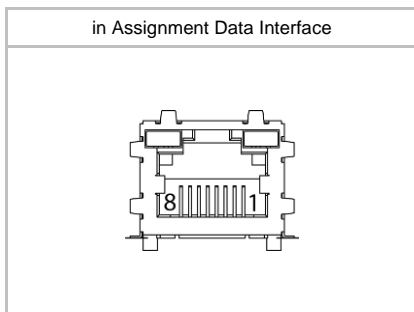

## Interfaces and Connectors

Data and Power Interface	Gigabit Ethernet	Transfer Rate	1000 Mbits/sec
	Fast Ethernet	Transfer Rate	100 Mbits/sec
	Connector:	8P8C Modular Jack (RJ45), screw lock type	
Process Interface	Connector:	M8/8-pin (SACC-DSI-M8MS-8CON-M8-L180)	
	Assignment:	1 - GPIO (Line2) 3 - IN1 (Line0) 5 - Power VCC OUT 7 - GND (Power, GPIO)	2 - MX1- 4 - MX3+ 6 - MX2- 8 - MX4- 4 - GND IN1 6 - OUT1 (Line3) 8 - GPIO (Line1)

Caution



\* Note GPIOs: Ground loops are to be avoided and can lead to destruction of the device.

## Optical Data

Lens Mount	C-Mount
Optical Filter	IR cut filter

## Mechanical Data

Housing	Zinc die casting, nickel-chrome-plated
Protection Class	IP40 (with mounted lens and GigE cable)
Weight	120 g
Dimensions	

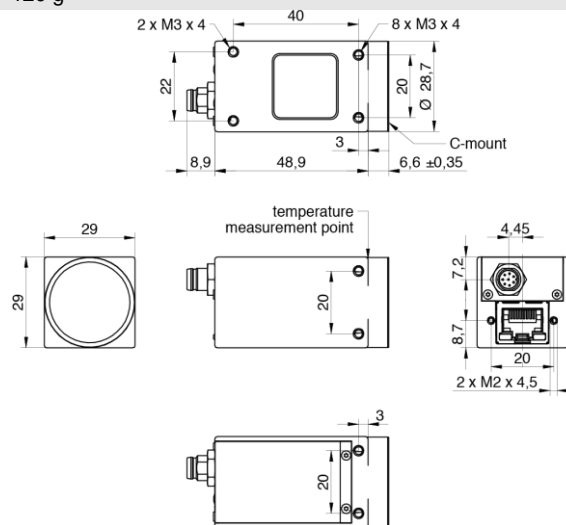

## Environmental Data

Storage Temperature	-10 °C ... + 70 °C
Operating Temperature	0 °C ... +65 °C @ T = Measurement Point or 0 °C ... +75 °C @ internal Temperature Sensor Ambient temperature above 30 °C requires heat dissipation measures.
Int. Temperature Sensor	yes, accuracy: ±2 °C (typ) -40 °C ... 0 °C ±1 °C (typ) 0 °C ... +85 °C
Humidity	10 % ... 90 % non-condensing

<sup>7)</sup> the maximum temperature for Sony sensor characteristics (sensor performance) are guaranteed up to 53°C @ Measurement Point or 60°C @ internal temperature sensor

## LED Signalling

LED	LED 1	Green static	Link ON
		Green flash	RX active
	LED 2	Yellow static	Error
		Yellow flash	TX active

## Electrical Data

Power Supply (ext.)	VCC: 12 ... 24 V DC $\pm$ 20% I: 116 ... 234 mA
Power over Ethernet	Class 1 device VCC: 36 ... 57 V DC I: 77 mA @ 48 VDC
Power Consumption	approx. 2.8 W @ 12VDC and 9 fps approx. 3.7 W @ 48 VDC (PoE) and 9 fps (Factory Setting "Default")
Digital Input	Optocoupler $U_{IN(low)}$ : 0.0 ... 4.5 VDC $U_{IN(high)}$ : 11.0 ... 30.0 VDC $I_{IN}$ : 3.0 ... 10.0 mA min. Impulse Length: 2.0 $\mu$ sec
Digital Output	Optocoupler $U_{EXT}$ : 5 ... 30 V DC $I_{OUT}$ : max. 50 mA $t_{ON}$ = typ. 3 $\mu$ sec $t_{OFF}$ = typ. 40 $\mu$ sec
GPIO	direct, without optocoupler
GPIO used as Input:	$U_{IN(low)}$ : 0.0 ... 0.8 VDC $U_{IN(high)}$ : 2.0 ... 30.0 VDC min. Impulse Length: 2.0 $\mu$ sec
GPIO used as Output:	$U_{Out(low)}$ : 0.0 ... 0.4 VDC ( $I_{sink\ max}$ : 50 mA) $U_{Out(high)}$ : 2.4 ... 3.3VDC ( $I_{max}$ : 1 mA)
Caution 	* The General Purpose I/Os (GPIOs) are not potential-free and do not have an overrun cut-off. Incorrect wiring (overvoltage, undervoltage or voltage reversal) can lead to defects in the electronic system. Ground loops are to be avoided and can lead to destruction of the device.

## Conformity

Conformity	CE, RoHS, REACH
KC Registration No. / Date	- / -
MTBF	51 years @ T = 45 °C / 33 years @ T = 60 °C T = Measurement Point

## GenICam™ Features

Short Exposure Range	yes, ShortExposureTimeEnable Short Exposure Range 1 $\mu$ sec ... 60 sec Default Exposure Range 15 $\mu$ sec ... 60 sec
Timer	Timer Selector: Timer 1 TimerTriggerSource: Line0, SoftwareTrigger, ExposureStart, ExposureEnd, FrameTransferSkipped, TriggerSkipped, Action 1 and Off TimerDelay: 0 $\mu$ sec ... 2 sec, Step Size: 1 $\mu$ sec TimerDuration: 4 $\mu$ sec ... 2 sec, Step Size: 1 $\mu$ sec
Counter	Counter Selector: Counter 1, Counter 2 CounterValue: 0 ... 65535 Counter Event Source: Counter1End or Counter2End, ExposureActive, FrameTransferSkipped, FrameTrigger, TriggerSkipped, Line0..2 and Off Counter Reset Source: Counter1End, Counter2End, Line0..2
Sequencer	Sequencer Characteristics: up to 128 sets, up to 4 possible pathes for triggered set transitions, 6 trigger sources: Counter1End, Counter2End, ExposureActive, Line0..2, ReadoutActive, Timer1End Sequencer Parameters for Exposure, Gain, Trigger, ROI and Output: ExposureTime, CounterDuration, CounterEventActivation, CounterEventSource, CounterResetSource, ExposureMode, ExposureTime, Gain, Height, OffsetX, OffsetY, TriggerMode, UserOutputValue, UserOutputValueAll, Width

## GenICam™ Features

User Sets	Factory Settings: UserSet0 (read only) Freely Programmable: UserSet1, UserSet2, UserSet3 Parameters: any user definable Parameter
Acquisition Abort	Delay up to 65.9 msec
Chunk Data	yes, Chunk Selector: Binning, BlackLevel, CounterValue, DeviceTemperature, ExposureTime, FrameID, Gain, Height, Image, ImageControl, LineStatusAll, OffsetX, OffsetY, PixelFormat, SequencerSetActive, Timestamp, TriggerID, Width
Device Temperature	InHouse Event generation for Normal to High, High to Exceeded and Exceeded to Normal Exceeded (no image transfer) = max. internal temperature sensor + 1 °C
Device Link Throughput Limit	yes, up to max. Device Link Speed
Custom Data	yes, 128 Byte
SFNC Version	v2.4

## Factory Settings after Start-Up

Ethernet IP Configuration	
Trigger Mode	Off (Free Running)
Analog Controls	Exposure Time: 4 msec, Gain: 0 dB, Offset: 0
Pixel Format	BayerRG8
Partial Scan	Off
Acquisition Frame Rate	Off
Timer/Counter/Sequencer	Off
Defect Pixel Correction	ON
Fixed Pattern Noise Correction	-
Digital Input	Line0, invert = false
Digital Output	Line3, invert = false, line source = Off
GPIO 1/2	Line1, Line2, invert = false, LineMode = Input
TriggerSource	All

## Partial Scan @ FullFrame, min Exposure, Mono8 (monochrome camera) or BayerRG8 (color camera)

	Resolution	max. fps acquisition	max. fps interface <sup>2)</sup>
UHD (4K)	3840 x 2160	20	14
Full HD	1920 x 1080	40	40
SXGA	1280 x 1024	42	42
HD720	1280 x 720	59	59
XGA	1024 x 768	56	56
SVGA	800 x 600	70	70
VGA	640 x 480	86	86
CIF	352 x 288	133	133
QVGA	320 x 240	155	155
QCIF	176 x 144	229	229
LineScan	4096 x 2048	22	14
	4096 x 1024	42	29
	4096 x 512	81	58
	4096 x 256	147	117
	4096 x 128	248	235
	4096 x 64	378	378
	4096 x 32	511	511
	4096 x 16	621	621
	4096 x 8	695	695
	4096 x 4	739	739
	4096 x 2	764	764
	4096 x 1	-	-

<sup>2)</sup> depends on the used interface