

**Digital Monochrome (b/w)
Progressive Scan Camera**

 System: **Gigabit Ethernet**

Baumer TXG14NIR

Revision 2.1

Art. No: 11044473

- Gigabit Ethernet progressive scan CCD camera
- 1392 x 1040 pixel
- Up to 20 full frames per second
- GigE Vision® standard compliant
- Outstanding image quality
- High sensitivity and dynamic range
- High quality slow scan mode for lowest readout noise
- Binning and true partial scan function (ROI) for increased frame rates
- External synchronization via industrial compliant process interface (trigger / flash)
- Integrated supplementary function for flexible integration
- Sequence function up to $2^{31}-1$ frames per sequence
- Jumbo frames supported
- Integrated 32 MByte RAM for temporarily image data buffering
- Camera parameter programmable in real-time
- Ultra compact and lightweight aluminum housing
- Standard RJ45 connector
- Screw-lock type industrial connector
- Baumer-GAPI: Flexible, generic software interface for Windows / Linux



1. Overview

Model Name	TXG14NIR
Sensor	2/3" interline progressive scan CCD Exview technology
Shutter / readout mode	global shutter / progressive scan readout
Number of pixel	1392 x 1040
Scan area	8.98 mm x 6.70 mm
Pixel size	6.45 μm x 6.45 μm
Color filter	-
Operation modes	
Trigger mode	yes, sequential operation
Free running mode	yes, sequential operation
Signal processing	real-time software programmable
Pixel clock	40 MHz fast scan / 20 MHz high quality (HQ) scan
A/D converter	12 bit
Exposure control (t_{exp})	total: 4 μsec .. 60 sec step: 1 μsec NIR-Mode starts at 250 μsec
Gain control	0 .. 20 dB
Offset (black level)	0 .. 255 LSB (12 bit)
Image data buffer	max. 7 images

Technical specifications subject to change

Image acquisition								
Camera image format modes		Format (pixel)	Gen\timesCam standard	Format ID	Pixel format	Pixel clock MHz	Frames per sec. *)	t _{readout}
Full frame HQ	slow	1392 x 1040	Vendor specific	00	Mono8 **)	20	10	100 msec
					Mono12			
					Mono12 Packed			
Full frame	fast	1392 x 1040	yes	01	Mono8 **)	40	20	50 msec
					Mono12			
					Mono12 Packed			
Binning 2x2 HQ	slow	696 x 520	Vendor specific	02	Mono8 **)	20	19	51 msec
					Mono12			
					Mono12 Packed			
Binning 2x2	fast	696 x 520	yes	03	Mono8 **)	40	39	26 msec
					Mono12			
					Mono12 Packed			
Binning 1x2 HQ	slow	1392 x 520	Vendor specific	04	Mono8 **)	20	19	51 msec
					Mono12			
					Mono12 Packed			
Binning 1x2	fast	1392 x 520	yes	05	Mono8 **)	40	39	26 msec
					Mono12			
					Mono12 Packed			
Binning 2x1 HQ	slow	696 x 1040	Vendor specific	06	Mono8 **)	20	10	100 msec
					Mono12			
					Mono12 Packed			
Binning 2x1	fast	696 x 1040	yes	07	Mono8 **)	40	20	50 msec
					Mono12			
					Mono12 Packed			
Standard features								
Image size controls								
Binning horizontal	yes, 1 or 2							
Binning vertical	yes, 1 or 2							
Pixel format	Mono8, Mono12, Mono12Packed							
Test image selector	yes, in all modes Off, GreyHorizontalRamp, GreyVerticalRamp, HorizontalLineMoving, VerticalLineMoving HorizontalAndVerticalLineMoving							
Partial scan	yes, format freely programmable in all modes (binning on partial scan ok)							
Analog controls								
Gain	yes							
Black Level (Off set)	yes							
Gamma	yes, user programmable (available if LUT is enable) ****) total: 0.001 .. 2							
Brightness correction (custom)	yes, in all binning modes							
Acquisition and Trigger								
Acquisition mode	Continuous							

Acquisition frame rate	yes, ON / OFF (only in freerunning mode) 0 .. 182 Hz step: 0.01 Hz
Trigger source	HardwareTrigger (Line0), SoftwareTrigger, CommandTrigger (ActionCommand), All or Off
Trigger delay	0 .. 2 sec, 512 trigger can be tracked, step: 1 µsec
Sequencer	Up to 2 ³¹ -1 frames per sequence / one exposure time and gain value for each parameter set max. set of sequences: Up to 2 ³¹ -1 frames x 256 parameter sets
Digital I/O	
Lines	Input: Line0, Output: Line1
Line source (outputs only)	Line1: Off, ExposureActive, Timer1, ReadoutActive, User0, TriggerReady, TriggerSkipped
Line debouncer	yes, low and high signal separately selectable 0 .. 5 msec step: 1 µsec
Event Generation	
Events	GigEVisionError, Heartbeattimeout, EventLost, Line0RisingEdge, Line0FallingEdge, Line1RisingEdge, Line1FallingEdge, ExposureStart, ExposureEnd, FrameStart, FrameEnd, TriggerReady, TriggerSkipped
Event Notification	yes, ON / OFF
Counters and Timers	
Framecounter	yes, 2 ³² can be set by user
Timer	yes, TimerSelector: Timer1 TimerTriggerSource: Off, Input: Line0, SoftwareTrigger, CommandTrigger (ActionCommand), ExposureStart, ExposureEnd, FrameStart, FrameEnd, TriggerSkipped TimerDelay: 0 µsec .. 2 sec, step: 1 µsec TimerDuration: 10 µsec .. 2 sec, step: 1 µsec
LUT Controls	
LUT selector	1 LUT: Luminance (12 bit) ON / OFF
Defect pixel correction (custom)	yes, ON / OFF
Defect pixel list (custom)	yes, max. 256 pixel coordinates (x, y) can be stored
GigEVisionTransportLayer	
PayLoadsize	4 Byte ... 2.895.632 Byte
TransmissionDelay (custom)	0 .. 2 ³² -1 ticks
UserSets	
User set selector	Default (factory settings / read only) UserSet1, UserSet2, UserSet3 (read and write)
UserSetDefaultSelector	yes, define the start up "UserSet"
Advanced features	
Time stamp function	yes, 64 bit tick = 32 nsec
Asynchronous message channel	yes
Concatenation function	yes
User defined identifier	yes, user programmable permanent identifier
ActionCommand	yes, ID 0 = Trigger
DeviceTemperature	no
Data quality	at 20 °C, gain = 1, exposure time = 32 msec, full frame mode, slow scan
Readout noise	σ < 0.5 LSB (8 bit) typical
Dynamic range	typical > 54 dB
Optical interface	C-Mount on request: CS-Mount
Optical filter	dust protection on request: super polished, IR cut filter, daylight filter or no filter

Technical specifications subject to change

Process interface functions	
Async. Trigger	yes, trigger mode operation, "Off", "software trigger", "hardware trigger", "command trigger" or "all" separately selectable (overtriggered signals and trigger signals during the readout time will be notified in the received image header)
Exposure Active (External flash sync)	yes, delay_value ($t_{\text{delay flash}}$) $\leq 4 \mu\text{sec}$, duration_value (t_{duration}): slow mode = $t_{\text{exp}} + 94 \mu\text{sec}$ fast mode = $t_{\text{exp}} + 47 \mu\text{sec}$
User Output	yes, ON / OFF
Timer	yes, Timer1
Software reset	yes, delay up to 102 msec
Asynchronous reset	Full frame / Binning 2x1 slow delay up to 21.3 msec fast 10.7 msec
	Binning 2x2 / Binning 1x2 slow delay up to 11.0 msec fast 5.5 msec
Image info header	yes
Electrical interface	
Data / control	standard single cable 1000 Base-T, Cat6 recommended / minimum Cat5e option: screw lock type connector
Power	VCC: 8 VDC .. 30 VDC I: 450 mA .. 135 mA
Power consumption	approx. 4 Watt
Digital input	Line0: trigger signal, opto decoupled $U_{\text{IN(low)}} = 0 \dots 4.5 \text{ VDC}$, $U_{\text{IN(high)}} = 11 \dots 30 \text{ VDC}$ $I_{\text{IN}} = 6 \dots 10 \text{ mA} / 7 \text{ mA typical}$ rising edge (invert = false) **** min. impulse length (t_{min}): 2 μsec trigger delay out of t_{readout} ($t_{\text{delay trigger}}$): 5 μsec
Digital output	Line 1: opto decoupled $U_{\text{EXT}} = 5 \dots 30 \text{ VDC} / 24 \text{ VDC typical}$, $I_{\text{OUT}} = \text{max. } 16 \text{ mA}$ high active (invert = false) ****
LED	1: green: Power on yellow: Readout active 2: green: Link Phy (1 GBit) green flash: Ethernet RX yellow: Ethernet TX yellow/red flash: Ethernet RX/TX
Environmental	
Storage temperature	-10 °C .. +70 °C
Operating temperature	+5 °C .. +50 °C
Housing operating temperature	between +36 °C .. +50 °C, note the max. housing temperature max. +50 °C *****) (measurement point, see item 4)
Humidity	10 % .. 90 % non condensing
Conformity	CE, FCC Part 15 class B, RoHS compliant
Housing	
Dimensions	36 x 36 x 48 mm ³
Weight	< 100 g
Network interface	
Ethernet IP configuration	1000BASE-T (1000 Mbit / sec) persistent IP / DHCP / LLA
Stream channel packet size	576 Byte (default) .. 65535 Byte jumbo frames supported
Interpacketgap	0 .. 2 ³² -1 ticks
Multicast function	yes
Resend function	yes

Technical specifications subject to change

Software	Baumer-GAPI SDK with supported OS socket driver and Baumer filter driver / SDK for Windows XP (32 bit) / Windows Vista (32 bit / 64 bit) / Windows 7 (32 bit / 64 bit) / Linux Kernel 2.6.xx (64 bit / 32 bit)
	GigE Vision® compatible programs and image processing libraries supported Windows / Linux depending on the actually driver software is used

- *) maximum frame rate in free running mode, effective frame rate depending on camera image format mode settings and set exposure time ($t_{exp} < t_{readout}$)
- ***) default pixel format
- ****) the LUT function will be used for the gamma value and the calculation time of the internal used LUT need app. 2 sec, if the gamma value changed
- *****) can be inverted via software
- *****) housing temperature is limited by CCD sensor specification

2. Camera Factory Settings after Camera Start-up

Camera factory settings after camera start-up	
Operation modes	free running mode
Signal processing	
Exposure control	32 msec
Gain control	factor 1 = 0 dB
Offset (black level)	0
Image acquisition	
Camera image format mode	mode id = 01, full frame Mono8
Partial scan function	not active
Acquisition frame rate	Off
Timer	Off
Transmission delay	0 ticks
Test image selector	Off
Defect pixel correction	On
Electrical interface	
Digital input	1: Line0 disabled, digital output set to low status (high impedance) invert = false line source = Exposure Active
Digital output	1: Line1 disabled invert = false trigger source = Line0

3. Timing Operation Modes

Trigger Mode: start up time

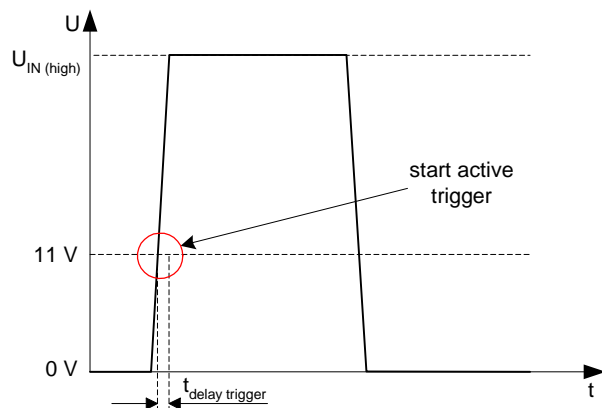

Technical specifications subject to change

Trigger Mode: trigger mode 0, sequential operation

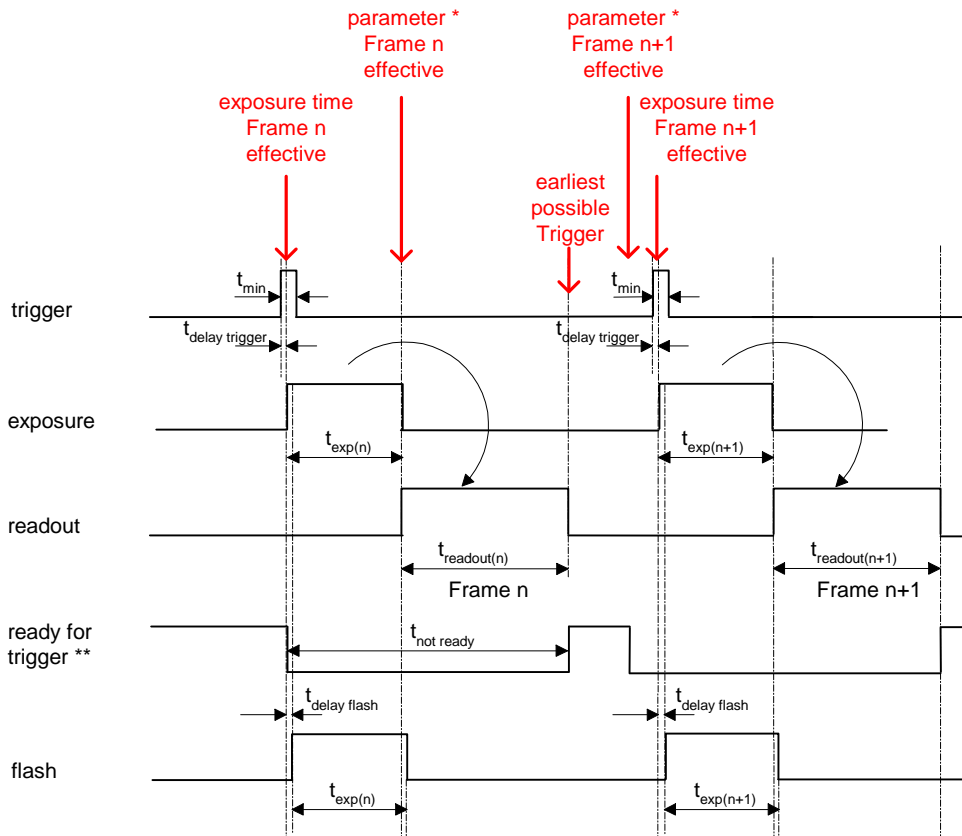

$$t_{\text{earliest possible trigger (n+1)}} = t_{\exp(n)} + t_{\text{readout}(n)}$$

$$t_{\text{not ready (n+1)}} = t_{\exp(n)} + t_{\text{readout}(n)}$$

* image parameter: offset
global gain
mode
partial scan

4. Spectral Sensitivity

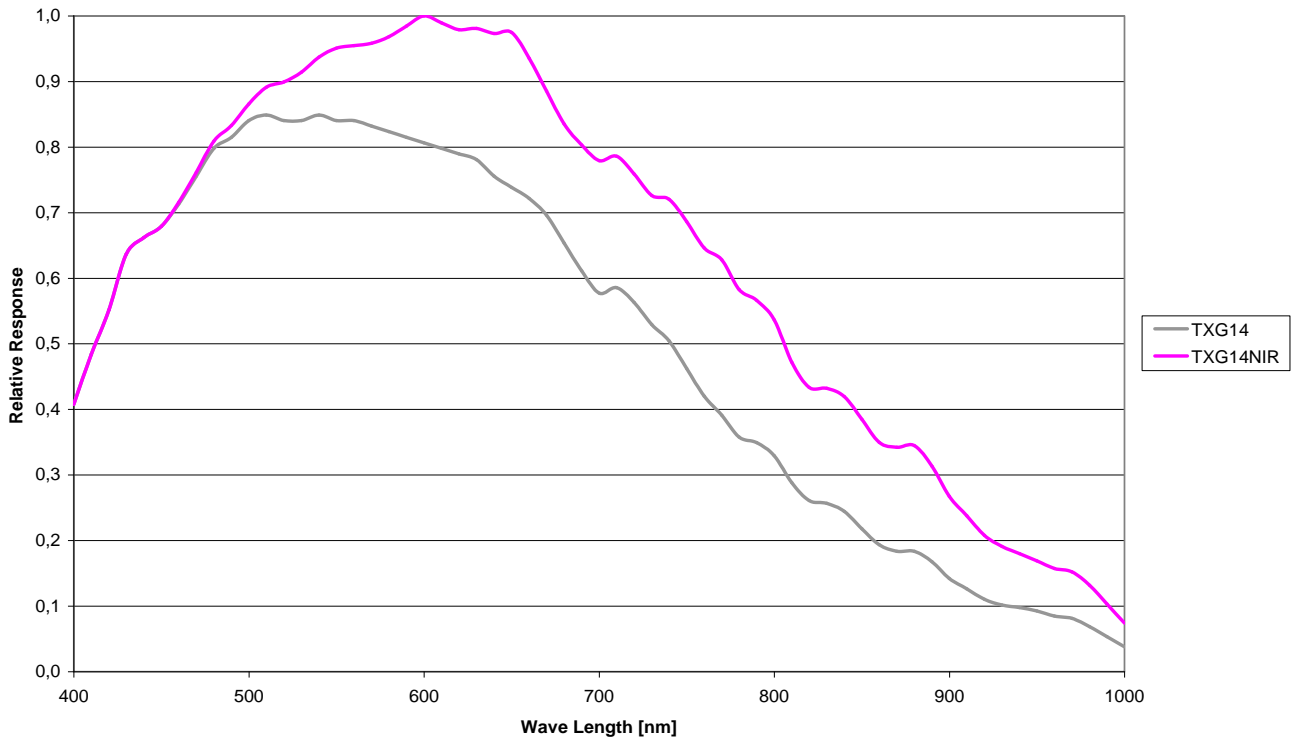

Please note: the measured sensitivity improvement for the TXG14NIR reflects a typical value - it can not be guaranteed for every camera.

5. Housing

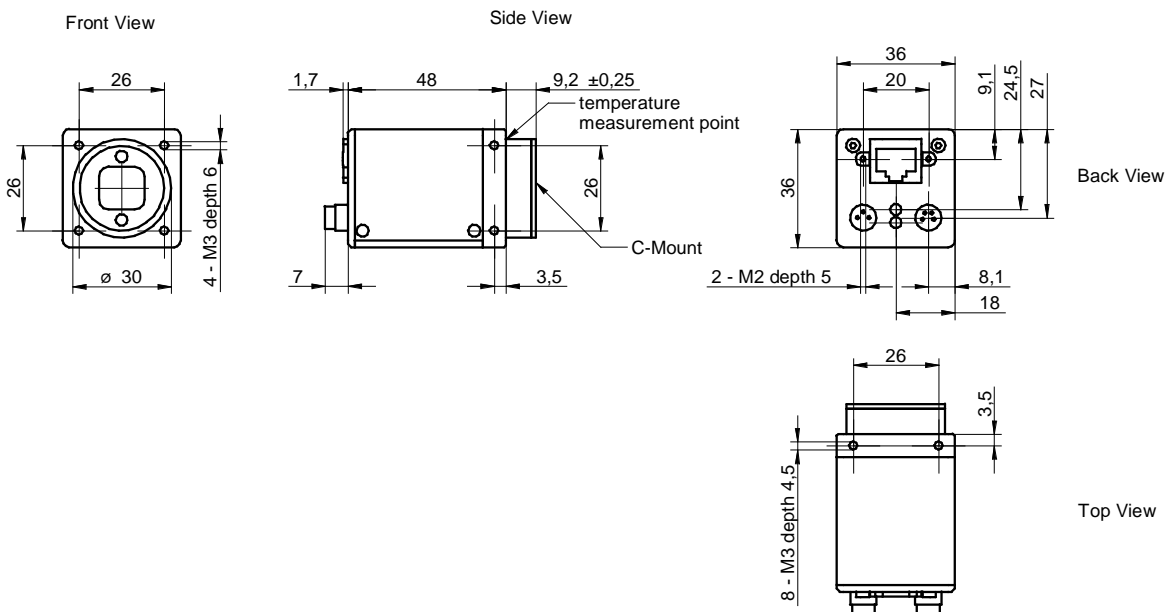



Technical specifications subject to change

6. Connectors / Electrical Interfaces

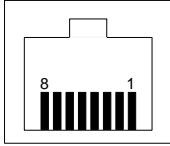
6.1 Pin assignment:

Data / Control 1000 Base-T	Type: RJ45 8P8C mod jack
	1: MX1+ 2: MX1- 3: MX2+ 4: MX3+ 5: MX3- 6: MX2- 7: MX4+ 8: MX4-

Power	Type: Lumberg RSMESD / 3 pin
	1: Power VCC+ 3: Power GND 4: not used
	Power cable wires color: 1 = brown 3 = blue 4 = black

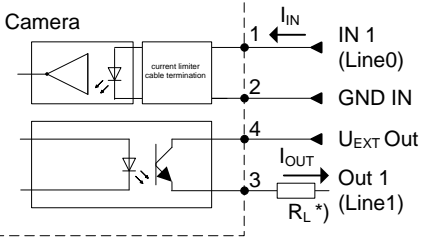
Trigger Flash	/ Type: Lumberg RSMESD 4pin.
	<div style="border: 1px dashed black; padding: 5px;">  </div> <p>*) resistor must be used, $I_{OUT} = 16 \text{ mA}$ by $U_{EXT} = 24 \text{ VDC}$ recommended, drawing shown above example for using high active signal</p> <p>Trigger / Flash cable wires color *): 1 = brown 2 = white 3 = blue 4 = black</p>

*) shielded trigger / flash cable should be used and ordered separately

6.2 Flash sync sample $U_{EXT} = 24 \text{ VDC}$ high active:

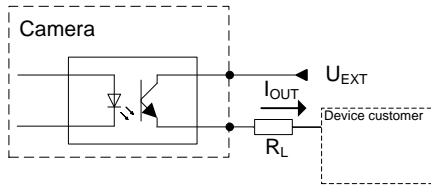

Timing example:
 measurement condition $U_{EXT} = 24 \text{ VDC} / I_{OUT} = 16 \text{ mA}$
 $R_L = 1.5 \text{ kOhm}$

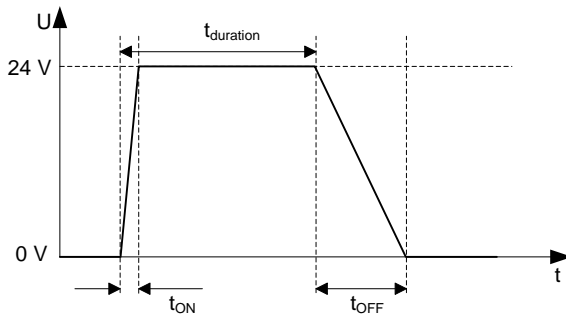

t_{ON} time = typ. $2 \mu\text{sec}$
 t_{OFF} time = typ. $40 \mu\text{sec}$

6.3 Flash sync sample $U_{EXT} = 24 \text{ VDC}$ low active:

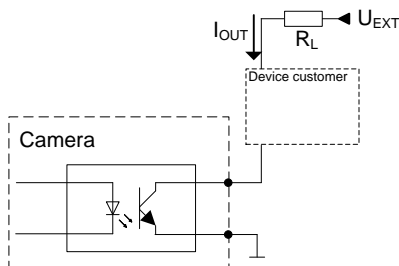

Timing example:
 measurement condition $U_{EXT} = 24 \text{ VDC} / I_{OUT} = 16 \text{ mA}$
 $R_L = 1.5 \text{ kOhm}$

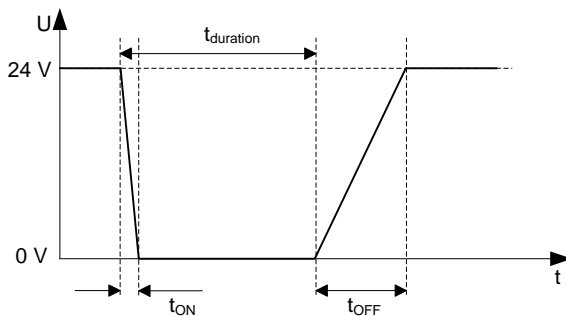

t_{ON} time = typ. $2 \mu\text{sec}$
 t_{OFF} time = typ. $40 \mu\text{sec}$

End of Document

Technical specifications subject to change