

**Digital Color  
Progressive Scan Camera**

 System: **Gigabit Ethernet**

# Baumer TXG13c

Revision 2.1

**Art. No: 11008728 (OD108073)**

- Gigabit Ethernet progressive scan CCD camera
- 1384 x 1036 pixel
- Up to 20 full frames per second
- GigE Vision® standard compliant
- On board integrated color processor for high quality color calculation
- Outstanding image quality
- High sensitivity and dynamic range
- High quality slow scan mode for lowest readout noise
- True partial scan function (ROI) for increased frame rates
- External synchronization via industrial compliant process interface (trigger / flash)
- Integrated supplementary function for flexible integration
- Jumbo frames supported
- Integrated 32 MByte RAM for temporarily image data buffering
- Camera parameter programmable in real-time
- Ultra compact and lightweight aluminum housing
- Standard RJ45 connector
- Screw-lock type industrial connector
- Baumer-GAPI: Flexible, generic software interface for Windows / Linux



## 1. Overview

Model Name	TXG13c
<b>Sensor</b>	1/2" interline progressive scan CCD
Shutter / readout mode	global shutter / progressive scan readout
Number of pixel	1384 x 1036
Scan area	6.44 mm x 4.82 mm
Pixel size	4.65 µm x 4.65 µm
Color filter	RGB Bayer mosaic
<b>Operation modes</b>	
Trigger mode	yes, overlapped operation
Free running mode	yes, overlapped operation
<b>Signal processing</b>	real-time software programmable
Pixel clock	40 MHz fast scan / 20 MHz high quality (HQ) scan
A/D converter	12 bit
Exposure control ( $t_{exp}$ )	total: 4 µsec .. 60 sec step: 1 µsec
Gain control	0 .. 20 dB
Offset (black level)	0 .. 255 LSB (12 bit)
Image data buffer	max. 3 images

Technical specifications subject to change

Image acquisition							
Camera image format modes	Format (pixel)	GenCam standard	Format ID	Pixel format	Pixel clock MHz	Frames per sec. *)	t <sub>readout</sub>
Full frame HQ slow	1384 x 1036	Vendor specific	00	BayerRG8	20	10	100 msec
				BayerRG12			
				Mono8			
				YUV411 Packed			
				YUV422 Packed **)			
				YUV444 Packed			
				RGB8 Packed			
Full frame fast	1384 x 1036	yes	01	BayerRG8	40	20	50 msec
				BayerRG12			
				Mono8			
				YUV411 Packed			
				YUV422 Packed **)			
				YUV444 Packed			
				RGB8 Packed			
BGR8 Packed							
<b>Standard features</b>							
<b>Image size controls</b>							
Pixel format	BayerRG8, BayerRG12, Mono8, YUV411 Packed, YUV422 Packed, YUV444 Packed, RGB8 Packed, BGR8 Packed						
Test image selector	yes, in all modes Off, GreyHorizontalRamp, GreyVerticalRamp, HorizontalLineMoving, VerticalLineMoving, HorizontalAndVerticalLineMoving						
Partial scan	yes, format freely programmable in all modes						
<b>Analog controls</b>							
Gain	yes						
Black Level (Off set)	yes						
Gamma	no						
<b>Acquisition and Trigger</b>							
Acquisition mode	Continuous						
Acquisition frame rate	yes, ON / OFF (only in freerunning mode) 0 .. 93 Hz, step: 0.01 Hz						
Trigger source	HardwareTrigger (Line0), SoftwareTrigger, CommandTrigger (ActionCommand), All or Off						
Trigger delay	0 .. 2 sec, 512 trigger can be tracked, step: 1 µsec						
Sequencer	no						
<b>Digital I/O</b>							
Lines	Input: Line0, Output: Line1						
Line source (outputs only)	Line1: Off, ExposureActive, Timer1, ReadoutActive, User0, TriggerReady, TriggerOverlapped, TriggerSkipped						
Line debouncer	yes, low and high signal separately selectable 0 .. 5 msec step: 1 µsec						
<b>Event Generation</b>							
Events	GigEVisionError, Heartbeattimeout, EventLost, Line0RisingEdge, Line0FallingEdge, Line1RisingEdge, Line1FallingEdge, ExposureStart, ExposureEnd, FrameStart, FrameEnd, TriggerReady, TriggerOverlapped, TriggerSkipped						
Event Notification	yes, ON / OFF						
<b>Counters and Timers</b>							
Framecounter	yes, 2 <sup>32</sup> can be set by user						
Timer	yes, TimerSelector: Timer1 TimerTriggerSource: Off, Input: Line0, SoftwareTrigger, CommandTrigger (ActionCommand), ExposureStart, ExposureEnd, FrameStart, FrameEnd, TriggerSkipped TimerDelay: 0 µsec .. 2 sec, step: 1 µsec TimerDuration: 10 µsec .. 2 sec, step: 1 µsec						

Technical specifications subject to change

<b>LUT Controls</b>			
LUT selector	no		
Defect pixel correction (custom)	yes, ON / OFF		
Defect pixel list (custom)	yes, max. 256 pixel coordinates (x, y) can be stored		
<b>GigEVisionTransportLayer</b>			
PayLoadsize	4 Byte .. 4.301.744 Byte		
TransmissionDelay (custom)	0 .. 2 <sup>32</sup> -1 ticks		
<b>UserSets</b>			
User set selector	Default (factory settings / read only) UserSet1, UserSet2, UserSet3 (read and write)		
UserSetDefaultSelector	yes, define the start up "UserSet"		
<b>Advanced features</b>			
Time stamp function	yes, 64 bit tick = 32 nsec		
Asynchronous message channel	yes		
Concatenation function	yes		
User defined identifier	yes, user programmable permanent identifier		
ActionCommand	yes, ID 0 = Trigger		
DeviceTemperature	no		
<b>Data quality</b>			
at 20 °C, gain = 1, exposure time = 32 msec, full frame mode, slow scan			
Readout noise	$\sigma < 0.5$ LSB (8 bit) typical		
Dynamic range	typical > 54 dB		
<b>Optical interface</b>			
C-Mount on request: CS-Mount			
Optical filter	Hoya E-CM500S on request: dust protection, daylight filter or no filter		
<b>Process interface functions</b>			
Async. Trigger	yes, trigger mode operation, "Off", "software trigger", "hardware trigger", "command trigger" or "all" separately selectable (overtriggered signals and trigger signals during the readout time will be notified in the received image header)		
Exposure Active (External flash sync)	yes, delay_value ( $t_{\text{delay flash}}$ ) $\leq 4$ $\mu\text{sec}$ , duration_value ( $t_{\text{duration}}$ ): slow mode = $t_{\text{exp}} + 94$ $\mu\text{sec}$ fast mode = $t_{\text{exp}} + 47$ $\mu\text{sec}$		
User Output	yes, ON / OFF		
Timer	yes, Timer1		
Software reset	yes, delay up to 102 msec		
Asynchronous reset	Full frame	slow fast	delay up to 21.3 msec 10.7 msec
Image info header	yes		
<b>Electrical interface</b>			
Data / control	standard single cable 1000 Base-T, Cat6 recommended / minimum Cat5e option: screw lock type connector		
Power	VCC: 8 VDC .. 30 VDC I: 450 mA .. 135 mA		
Power consumption	approx. 4 Watt		
Digital input	Line 0: trigger signal, opto decoupled $U_{\text{IN(low)}} = 0 \dots 4.5$ VDC, $U_{\text{IN(high)}} = 11 \dots 30$ VDC $I_{\text{IN}} = 6 \dots 10$ mA / 7 mA typical rising edge (invert = false) *** min. impulse length ( $t_{\text{min}}$ ): 2 $\mu\text{sec}$ trigger delay out of $t_{\text{readout}}$ ( $t_{\text{delay trigger}}$ ): 5 $\mu\text{sec}$ max. trigger delay during $t_{\text{readout}}$ ( $t_{\text{delay trigger}}$ ): slow mode = 94 $\mu\text{sec}$ fast mode = 47 $\mu\text{sec}$		
Digital output	Line 1: opto decoupled $U_{\text{EXT}} = 5 \dots 30$ VDC / 24 VDC typical, $I_{\text{OUT}} = \text{max. } 16$ mA high active (invert = false) ***		
LED	1:	green: yellow:	Power on Readout active
	2:	green: green flash: yellow: yellow/red flash:	Link Phy (1 GBit) Ethernet RX Ethernet TX Ethernet RX/TX

Technical specifications subject to change

<b>Environmental</b>	
Storage temperature	-10 °C .. +70 °C
Operating temperature	+5 °C .. +50 °C ****) between +38 °C .. +50 °C, note the max. housing temperature
Housing operating temperature	max. +50 °C
Humidity	10 % .. 90 % non condensing
Conformity	CE, FCC Part 15 class B, UL, RoHS compliant
<b>Housing</b>	
Dimensions	aluminum, IP40 36 x 36 x 48 mm <sup>3</sup>
Weight	< 90 g
<b>1000 Base-T interface</b>	
Ethernet IP configuration	1000BASE-T (1000 Mbit / sec) persistent IP / DHCP / LLA
Stream channel packet size	576 Byte (default) .. 65535 Byte jumbo frames supported
Interpacketgap	0 .. 2 <sup>32</sup> -1 ticks
Multicast function	yes
Resend function	yes
<b>Software</b>	
Baumer-GAPI SDK with supported OS socket driver and Baumer filter driver / SDK for Windows XP (32 bit) / Windows Vista (32 bit / 64 bit) / Windows 7 (32 bit / 64 bit) / Linux Kernel 2.6.xx (64 bit / 32 bit)	
GigE Vision <sup>®</sup> compatible programs and image processing libraries supported Windows / Linux depending on the actually driver software is used	

- \*) maximum frame rate in free running mode, effective frame rate depending on camera image format mode settings and set exposure time ( $t_{exp} < t_{readout}$ )
- \*\*) default pixel format
- \*\*\*) can be inverted via software
- \*\*\*\*) housing temperature is limited by CCD sensor specification

## 2. Camera Factory Settings after Camera Start-up

Camera factory settings after camera start-up	
<b>Operation modes</b>	free running mode
<b>Signal processing</b>	
Exposure control	32 msec
Gain control	factor 1 = 0 dB
Offset (black level)	0
<b>Image acquisition</b>	
Camera image format mode	mode id = 01, full frame YUV422 Packed
Partial scan function	not active
Acquisition frame rate	Off
Timer	Off
Transmission delay	0 ticks
Test image selector	Off
Defect pixel correction	On
<b>Electrical interface</b>	
Digital input	1: Line0 disabled, digital output set to low status (high impedance) invert = false line source = Exposure Active
Digital output	1: Line1 disabled invert = false trigger source = Line0

### 3. Timing Operation Modes

Trigger Mode: start up time

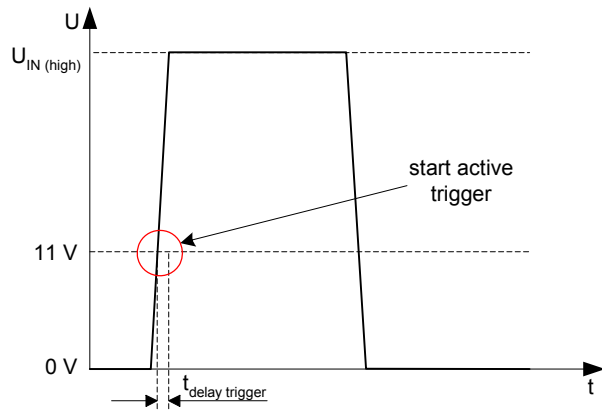

Trigger Mode: trigger mode 0, overlapped trigger

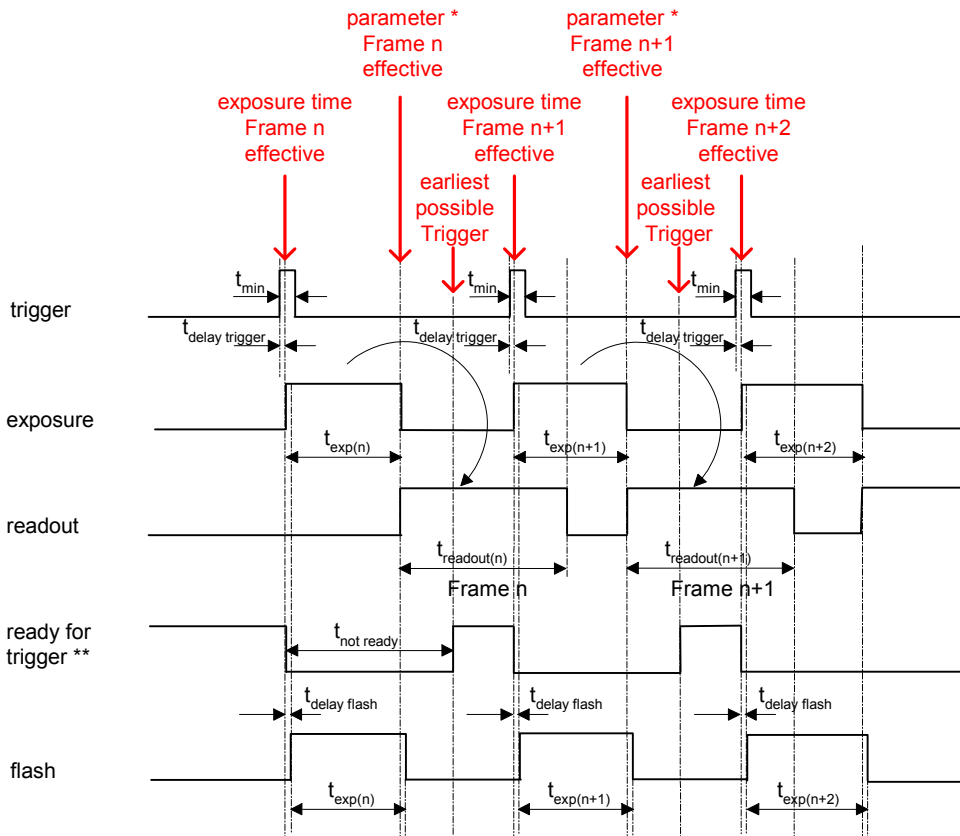

$$t_{exp} < t_{readout}: t_{\text{earliest possible trigger (n+1)}} = t_{readout(n)} - t_{exp(n+1)}$$

$$t_{exp} > t_{readout}: t_{\text{earliest possible trigger (n+1)}} = t_{exp(n)}$$

$$t_{exp} < t_{readout}: t_{\text{not ready (n+1)}} = t_{exp(n)} + t_{readout(n)} - t_{exp(n+1)}$$

$$t_{exp} > t_{readout}: t_{\text{not ready (n+1)}} = t_{exp(n)}$$

\* image parameter:    offset  
                               global gain  
                               mode  
                               partial scan

\*\* signal will be notified as event "TriggerReady" and is not available as digital output

Trigger Mode: trigger mode 0, overlapped trigger , when  $t_{exp(n+2)} > t_{exp(n+1)}$

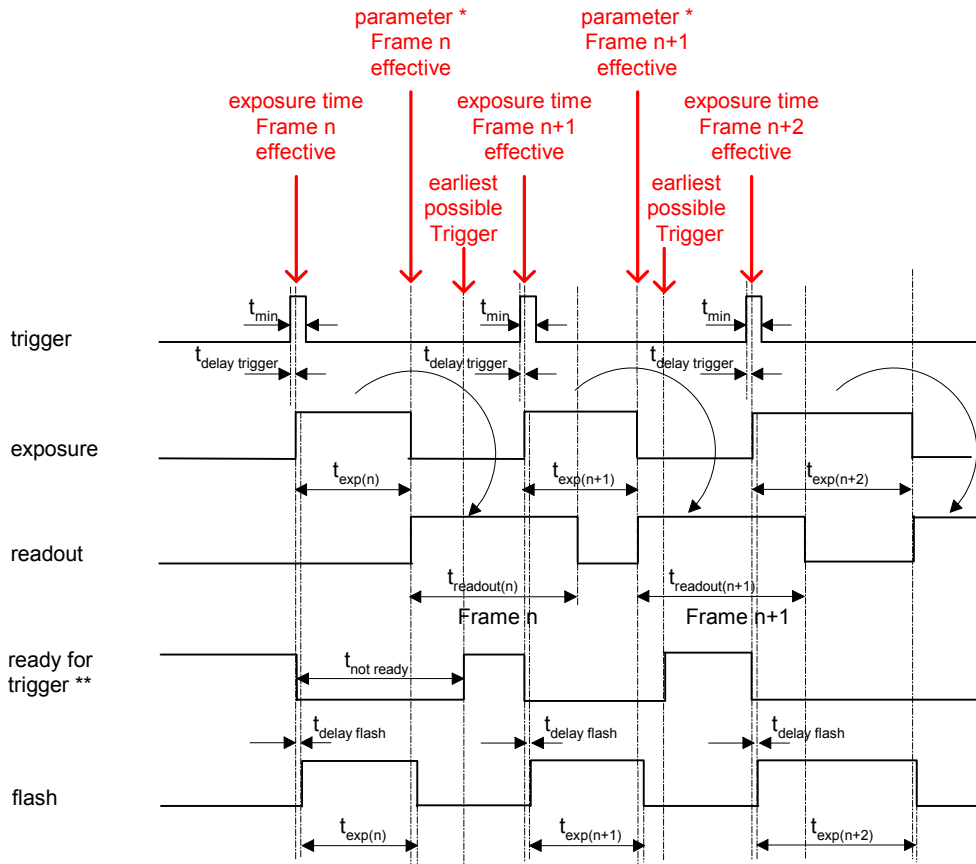

$$t_{exp} < t_{readout}: t_{earliest\ possible\ trigger\ (n+1)} = t_{readout(n)} - t_{exp(n+1)}$$

$$t_{exp} > t_{readout}: t_{earliest\ possible\ trigger\ (n+1)} = t_{exp(n)}$$

$$t_{exp} < t_{readout}: t_{not\ ready\ (n+1)} = t_{exp(n)} + t_{readout(n)} - t_{exp(n+1)}$$

$$t_{exp} > t_{readout}: t_{not\ ready\ (n+1)} = t_{exp(n)}$$

\* image parameter: offset  
global gain  
mode  
partial scan

\*\* signal will be notified as event "TriggerReady" and is not available as digital output

Trigger Mode: trigger mode 0, overlapped trigger , when  $t_{exp(n+2)} < t_{exp(n+1)}$

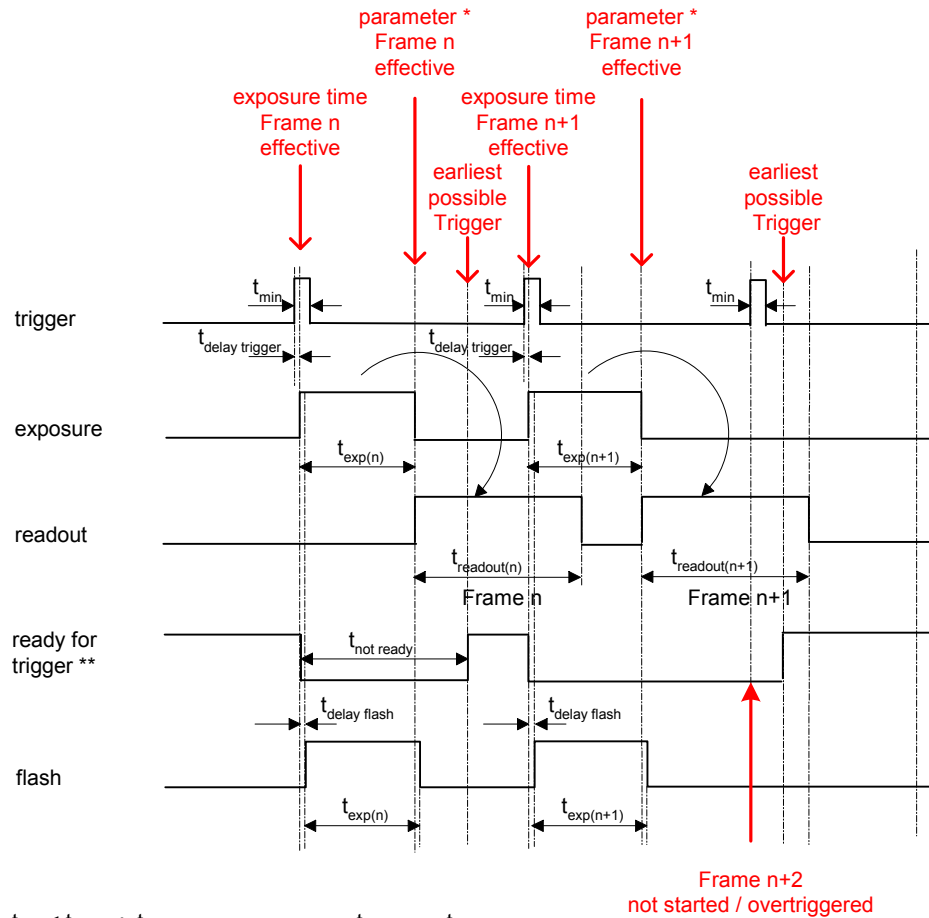

$$t_{exp} < t_{readout}: t_{earliest\ possible\ trigger\ (n+1)} = t_{readout(n)} - t_{exp(n+1)}$$

$$t_{exp} > t_{readout}: t_{earliest\ possible\ trigger\ (n+1)} = t_{exp(n)}$$

$$t_{exp} < t_{readout}: t_{not\ ready\ (n+1)} = t_{exp(n)} + t_{readout(n)} - t_{exp(n+1)}$$

$$t_{exp} > t_{readout}: t_{not\ ready\ (n+1)} = t_{exp(n)}$$

Frame n+2  
not started / overtriggered

\* image parameter: offset  
global gain  
mode  
partial scan

\*\* signal will be notified as event "TriggerReady" and is not available as digital output



Free Running Mode: overlapped operation

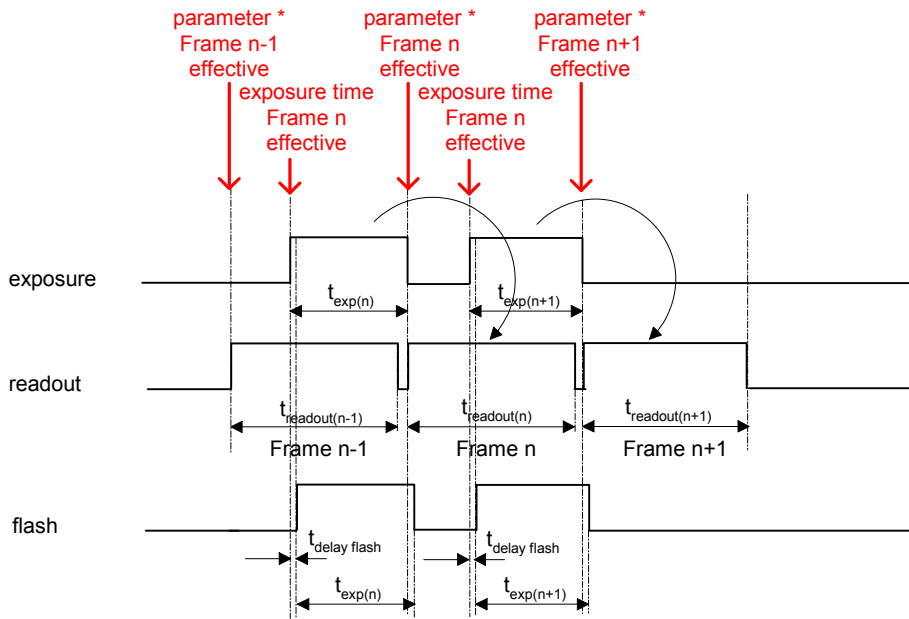

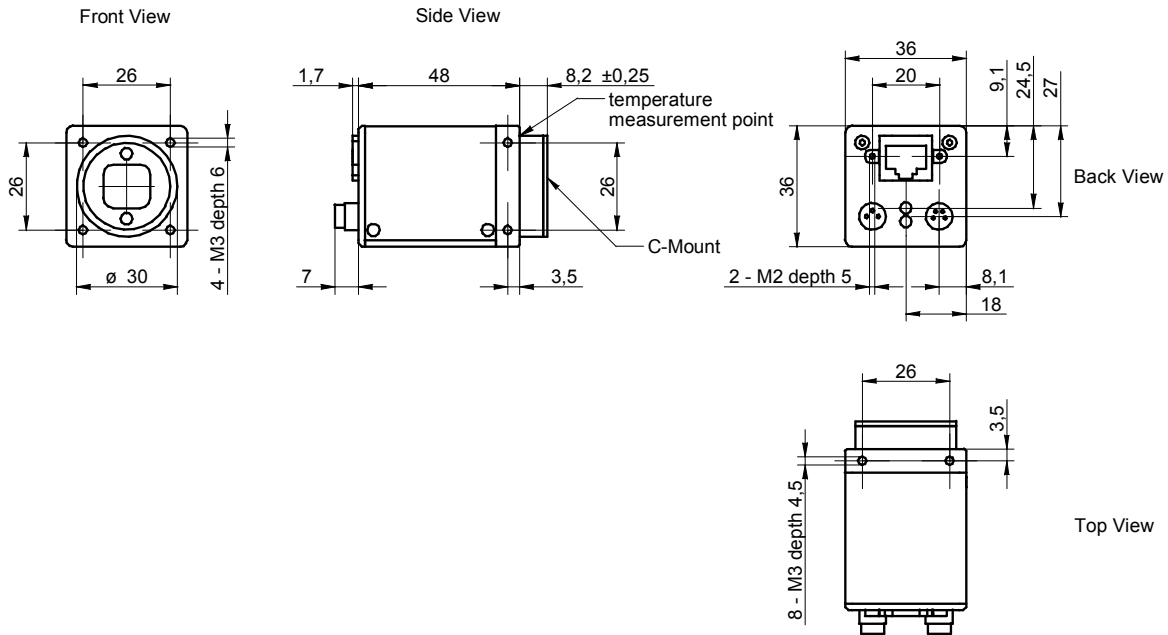

\* image parameter: offset  
global gain  
mode  
partial scan

### 4. Housing

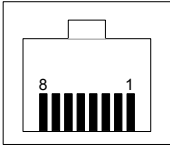

### 5. Connectors / Electrical Interfaces

#### 5.1 Pin assignment:

<b>Data / Control</b> <b>1000 Base-T</b>	Type: RJ45 8P8C mod jack
	<ul style="list-style-type: none"> <li>1: MX1+</li> <li>2: MX1-</li> <li>3: MX2+</li> <li>4: MX3+</li> <li>5: MX3-</li> <li>6: MX2-</li> <li>7: MX4+</li> <li>8: MX4-</li> </ul>
<b>Power</b>	Type: Lumberg RSMESD / 3 pin
	<ul style="list-style-type: none"> <li>1: Power VCC+</li> <li>3: Power GND</li> <li>4: not used</li> </ul>
	Power cable wires color: 1 = brown 3 = blue 4 = black

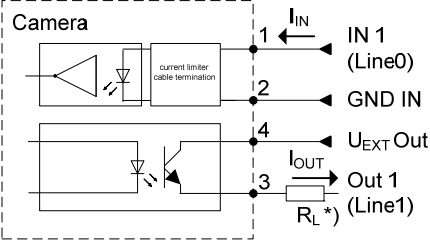
<b>Trigger / Flash</b>	Type: Lumberg RSMESD 4pin.
	
	*) resistor must be used, $I_{OUT} = 16 \text{ mA}$ by $U_{EXT} = 24 \text{ VDC}$ recommended, drawing shown above example for using high active signal
	Trigger / Flash cable wires color *): 1 = brown 2 = white 3 = blue 4 = black

\*) shielded trigger / flash cable should be used and ordered separately

5.2 Flash sync sample  $U_{EXT} = 24 \text{ VDC}$  high active:

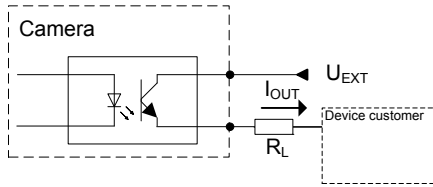

Timing example:  
 measurement condition  $U_{EXT} = 24 \text{ VDC} / I_{OUT} = 16 \text{ mA}$   
 $R_L = 1.5 \text{ kOhm}$

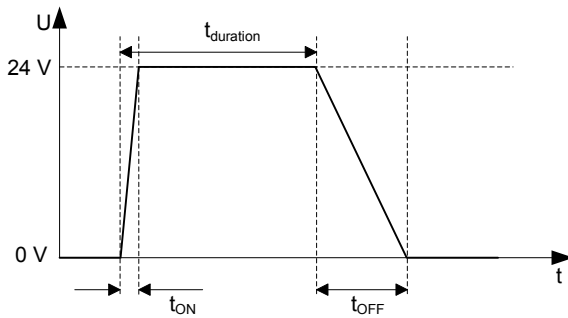

$t_{ON}$  time = typ.  $2 \mu\text{sec}$   
 $t_{OFF}$  time = typ.  $40 \mu\text{sec}$

5.3 Flash sync sample  $U_{EXT} = 24 \text{ VDC}$  low active:

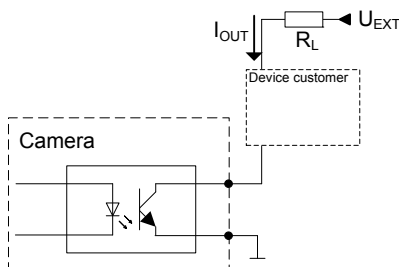

Timing example:  
 measurement condition  $U_{EXT} = 24 \text{ VDC} / I_{OUT} = 16 \text{ mA}$   
 $R_L = 1.5 \text{ kOhm}$

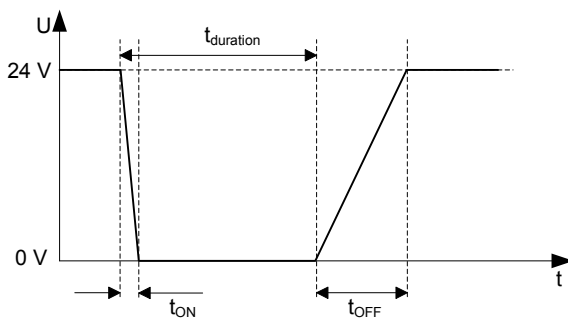

$t_{ON}$  time = typ.  $2 \mu\text{sec}$   
 $t_{OFF}$  time = typ.  $40 \mu\text{sec}$