

**Digital Monochrome (b/w)  
Progressive Scan Camera**

 System: **Gigabit Ethernet**
**Baumer TXG12**

Revision 2.1

**Art. No: 11046113**

- Gigabit Ethernet progressive scan CCD camera
- 1296 x 966
- Up to 32 full frames per second
- GigE Vision® standard compliant
- Outstanding image quality
- High sensitivity and dynamic range
- High quality slow scan mode for lowest readout noise
- Binning and true partial scan function (ROI) for increased frame rates
- External synchronization via industrial compliant process interface (trigger / flash)
- Integrated supplementary function for flexible integration
- Sequence function up to  $2^{31}-1$  frames per sequence
- Jumbo frames supported
- Integrated 32 MByte RAM for temporarily image data buffering
- Camera parameter programmable in real-time
- Ultra compact and lightweight aluminum housing
- Standard RJ45 connector
- Screw-lock type industrial connector
- Baumer-GAPI: Flexible, generic software interface for Windows / Linux

**1. Overview**

Model Name	TXG12
Sensor	1/3" interline progressive scan CCD EXview HAD technology
Shutter / readout mode	global shutter / progressive scan readout
Number of pixel	1296 x 966
Scan area	4.86 mm x 3.62 mm
Pixel size	3.75 µm x 3.75 µm
Color filter	-
<b>Operation modes</b>	
Trigger mode	yes, overlapped operation
Free running mode	yes, overlapped operation
<b>Signal processing</b>	real-time software programmable
Pixel clock	55 MHz fast scan / 27.5 MHz high quality (HQ) scan
A/D converter	14 bit
Exposure control ( $t_{exp}$ )	total: 4 µsec .. 60 sec step: 1 µsec
Gain control	0 .. 20 dB
Offset (black level)	0 .. 1023 LSB (14 bit)
Image data buffer	max. 7 images

Technical specifications subject to change

Image acquisition								
Camera image format modes	Format (pixel)	Gen<math>\times</math>Cam standard	Format ID	Pixel format	Pixel clock MHz	Frames per sec. *)	t <sub>readout</sub>	
Full frame HQ	slow	1296 x 966	Vendor specific	00	Mono8 **)	27.5	16	62 msec
					Mono12			
					Mono12 Packed			
Full frame	fast	1296 x 966	yes	01	Mono8 **)	55	32	31 msec
					Mono12			
					Mono12 Packed			
Binning 2x2 HQ	slow	648 x 483	Vendor specific	02	Mono8 **)	27.5	32	31 msec
					Mono12			
					Mono12 Packed			
Binning 2x2	fast	648 x 483	yes	03	Mono8 **)	55	65	16 msec
					Mono12			
					Mono12 Packed			
Binning 1x2 HQ	slow	1296 x 483	Vendor specific	04	Mono8 **)	27.5	32	31 msec
					Mono12			
					Mono12 Packed			
Binning 1x2	fast	1296 x 483	yes	05	Mono8 **)	55	65	16 msec
					Mono12			
					Mono12 Packed			
Binning 2x1 HQ	slow	648 x 966	Vendor specific	06	Mono8 **)	27.5	16	62 msec
					Mono12			
					Mono12 Packed			
Binning 2x1	fast	648 x 966	yes	07	Mono8 **)	55	32	31 msec
					Mono12			
					Mono12 Packed			
<b>Standard features</b>								
<b>Image size controls</b>								
Binning horizontal	yes, 1 or 2							
Binning vertical	yes, 1 or 2							
Pixel format	Mono8, Mono12, Mono12Packed							
Test image selector	yes, in all modes Off, GreyHorizontalRamp, GreyVerticalRamp, HorizontalLineMoving, VerticalLineMoving HorizontalAndVerticalLineMoving							
Partial scan	yes, format freely programmable in all modes (binning on partial scan ok)							
<b>Analog controls</b>								
Gain	yes							
Black Level (Off set)	yes							
Gamma	yes, user programmable ***) (available if LUT is enable) ****) total: 0.001 .. 2							
Brightness correction (custom)	yes, in all binning modes							

Technical specifications subject to change

<b>Acquisition and Trigger</b>	
Acquisition mode	Continuous
Acquisition frame rate	yes, ON / OFF (only in freerunning mode) 0 .. 395 Hz, step: 0.01 Hz
Trigger source	HardwareTrigger (Line0), SoftwareTrigger, CommandTrigger (ActionCommand), All or Off
Trigger delay	0 .. 2 sec, 512 trigger can be tracked, step: 1 µsec
Sequencer	Up to $2^{31}-1$ frames per sequence / one exposure time and gain value for each parameter set max. set of sequences: Up to $2^{31}-1$ frames x 256 parameter sets
<b>Digital I/O</b>	
Lines	Input: Line0, Output: Line1
Line source (outputs only)	Line1: Off, ExposureActive, Timer1, ReadoutActive, User0, TriggerReady, TriggerOverlapped, TriggerSkipped
Line debouncer	yes, low and high signal separately selectable 0 .. 5 msec step: 1 µsec
<b>Event Generation</b>	
Events	GigEVisionError, Heartbeattimeout, EventLost, Line0RisingEdge, Line0FallingEdge, Line1RisingEdge, Line1FallingEdge, ExposureStart, ExposureEnd, FrameStart, FrameEnd, TriggerReady, TriggerOverlapped, TriggerSkipped
Event Notification	yes, ON / OFF
<b>Counters and Timers</b>	
Framecounter	yes, $2^{32}$ can be set by user
Timer	yes, TimerSelector: Timer1 TimerTriggerSource: Off, Input: Line0, SoftwareTrigger, CommandTrigger (ActionCommand), ExposureStart, ExposureEnd, FrameStart, FrameEnd, TriggerSkipped TimerDelay: 0 µsec .. 2 sec, step: 1 µsec TimerDuration: 10 µsec .. 2 sec, step: 1 µsec
<b>LUT Controls</b>	
LUT selector	1 LUT: Luminance (12 bit) ON / OFF
Defect pixel correction (custom)	yes, ON / OFF
Defect pixel list (custom)	yes, max. 256 pixel coordinates (x, y) can be stored
<b>GigEVisionTransportLayer</b>	
PayLoadsize	4 Byte .. 648.400 Byte
TransmissionDelay (custom)	0 .. $2^{32}-1$ ticks
<b>UserSets</b>	
User set selector	Default (factory settings / read only) UserSet1, UserSet2, UserSet3 (read and write)
UserSetDefaultSelector	yes, define the start up "UserSet"
<b>Advanced features</b>	
Time stamp function	yes, 64 bit tick = 32 nsec
Asynchronous message channel	yes
Concatenation function	yes
User defined identifier	yes, user programmable permanent identifier
ActionCommand	yes, ID 0 = Trigger
DeviceTemperature	no
<b>Data quality</b>	
Readout noise	$\sigma < 0.5$ LSB (8 bit) typical
Dynamic range	typical > 54 dB
<b>Optical interface</b>	
Optical filter	C-Mount on request: CS-Mount dust protection on request: super polished, IR cut filter, daylight filter or no filter

<b>Process interface functions</b>	
Async. Trigger	yes, trigger mode operation, "Off", "software trigger", "hardware trigger", "command trigger" or "all" separately selectable (overtriggered signals and trigger signals during the readout time will be notified in the received image header)
Exposure Active (External flash sync)	yes, delay_value ( $t_{\text{delay flash}}$ ) $\leq 4 \mu\text{sec}$ , duration_value ( $t_{\text{duration}}$ ): slow mode = $t_{\text{exp}} + 62 \mu\text{sec}$ fast mode = $t_{\text{exp}} + 31 \mu\text{sec}$
User Output	yes, ON / OFF
Timer	yes, Timer1
Trigger Ready	yes
Trigger Overlapped	yes
Trigger Skipped	yes
Software reset	yes, delay up to 102 msec
Asynchronous reset	Full frame / Binning 2x1    slow    delay up to 10.8 msec fast                                    5.4 msec
	Binning 2x2 / Binning 1x2    slow    delay up to 5.5 msec fast                                    2.8 msec
Image info header	yes
<b>Electrical interface</b>	
Data / control	standard single cable 1000 Base-T, Cat6 recommended / minimum Cat5e option: screw lock type connector
Power	VCC: 8 VDC .. 30 VDC I: 450 mA .. 120 mA
Power consumption	approx. 3.6 Watt
Digital input	Line0: trigger signal, opto decoupled $U_{\text{IN(low)}} = 0 \dots 4.5 \text{ VDC}$ , $U_{\text{IN(high)}} = 11 \dots 30 \text{ VDC}$ $I_{\text{IN}} = 6 \dots 10 \text{ mA}$ / 7 mA typical rising edge (invert = false) **** min. impulse length ( $t_{\text{min}}$ ): 2 $\mu\text{sec}$ trigger delay out of $t_{\text{readout}}$ ( $t_{\text{delay trigger}}$ ): 1 $\mu\text{sec}$ max. trigger delay during $t_{\text{readout}}$ ( $t_{\text{delay trigger}}$ ): slow mode = 62 $\mu\text{sec}$ fast mode = 31 $\mu\text{sec}$
Digital output	Line 1: opto decoupled $U_{\text{EXT}} = 5 \dots 30 \text{ VDC}$ / 24 VDC typical, $I_{\text{OUT}} = \text{max. } 16 \text{ mA}$ high active (invert = false) ****
LED	1: green:            Power on yellow:        Readout active 2: green:            Link Phy (1 GBit) green flash:   Ethernet RX yellow:        Ethernet TX yellow/red flash: Ethernet RX/TX
<b>Environmental</b>	
Storage temperature	-10 °C .. +70 °C
Operating temperature	+5 °C .. +50 °C between +24 °C .. +50 °C, note the max. housing temperature
Housing operating temperature	max. +50 °C **** (measurement point, see item 4)
Humidity	10 % .. 90 % non condensing
Conformity	CE, FCC Part 15 class B, UL, RoHS compliant
<b>Housing</b>	
Dimensions	aluminum, IP40 36 x 36 x 48 mm <sup>3</sup>
Weight	< 90 g
<b>Network interface</b>	
Ethernet IP configuration	1000BASE-T (1000 Mbit / sec) persistent IP / DHCP / LLA
Stream channel packet size	576 Byte (default) .. 65535 Byte jumbo frames supported
Interpacketgap	0 .. 2 <sup>32</sup> -1 ticks
Multicast function	yes
Resend function	yes

Technical specifications subject to change

<b>Software</b>	Baumer-GAPI SDK with supported OS socket driver and Baumer filter driver / SDK for Windows XP (32 bit) / Windows Vista (32 bit / 64 bit) / Windows 7 (32 bit / 64 bit) / Linux Kernel 2.6.xx (64 bit / 32 bit)
	GigE Vision® compatible programs and image processing libraries supported Windows / Linux depending on the actually driver software is used

- \*) maximum frame rate in free running mode, effective frame rate depending on camera image format mode settings and set exposure time ( $t_{exp} < t_{readout}$ )
- \*\*\*) default pixel format
- \*\*\*\*) the LUT function will be used for the gamma value and the calculation time of the internal used LUT need app. 2 sec, if the gamma value changed
- \*\*\*\*\*) can be inverted via software
- \*\*\*\*\*) housing temperature is limited by CCD sensor specification

## 2. Camera Factory Settings after Camera Start-up

Camera factory settings after camera start-up	
<b>Operation modes</b>	free running mode
<b>Signal processing</b>	
Exposure control	32 msec
Gain control	factor 1 = 0 dB
Offset (black level)	0
<b>Image acquisition</b>	
Camera image format mode	mode id = 01, full frame Mono8
Partial scan function	not active
Acquisition frame rate	Off
Timer	Off
Transmission delay	0 ticks
Test image selector	Off
Defect pixel correction	On
<b>Electrical interface</b>	
Digital input	1: Line0 disabled, digital output set to low status (high impedance) invert = false trigger source = Line0
Digital output	1: Line1 disabled invert = false line source = Exposure Active

## 3. Timing Operation Modes

Trigger Mode: start up time

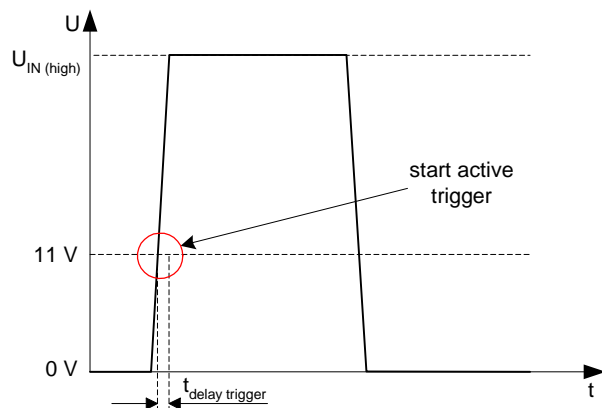

Technical specifications subject to change

Trigger Mode: trigger mode 0, overlapped trigger

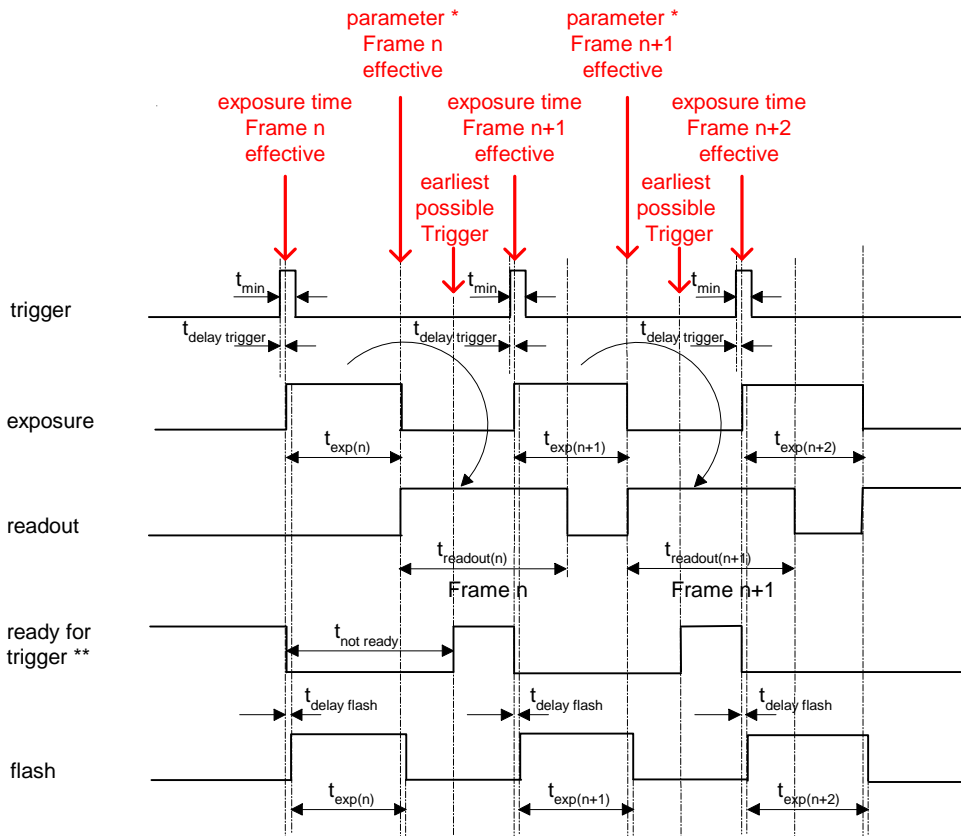

$$t_{exp} < t_{readout}: t_{\text{earliest possible trigger (n+1)}} = t_{readout(n)} - t_{exp(n+1)}$$

$$t_{exp} > t_{readout}: t_{\text{earliest possible trigger (n+1)}} = t_{exp(n)}$$

$$t_{exp} < t_{readout}: t_{\text{not ready (n+1)}} = t_{exp(n)} + t_{readout(n)} - t_{exp(n+1)}$$

$$t_{exp} > t_{readout}: t_{\text{not ready (n+1)}} = t_{exp(n)}$$

\* image parameter:    offset  
                               global gain  
                               mode  
                               partial scan

\*\* signal will be notified as event "TriggerReady"

Trigger Mode: trigger mode 0, overlapped trigger , when  $t_{exp(n+2)} > t_{exp(n+1)}$

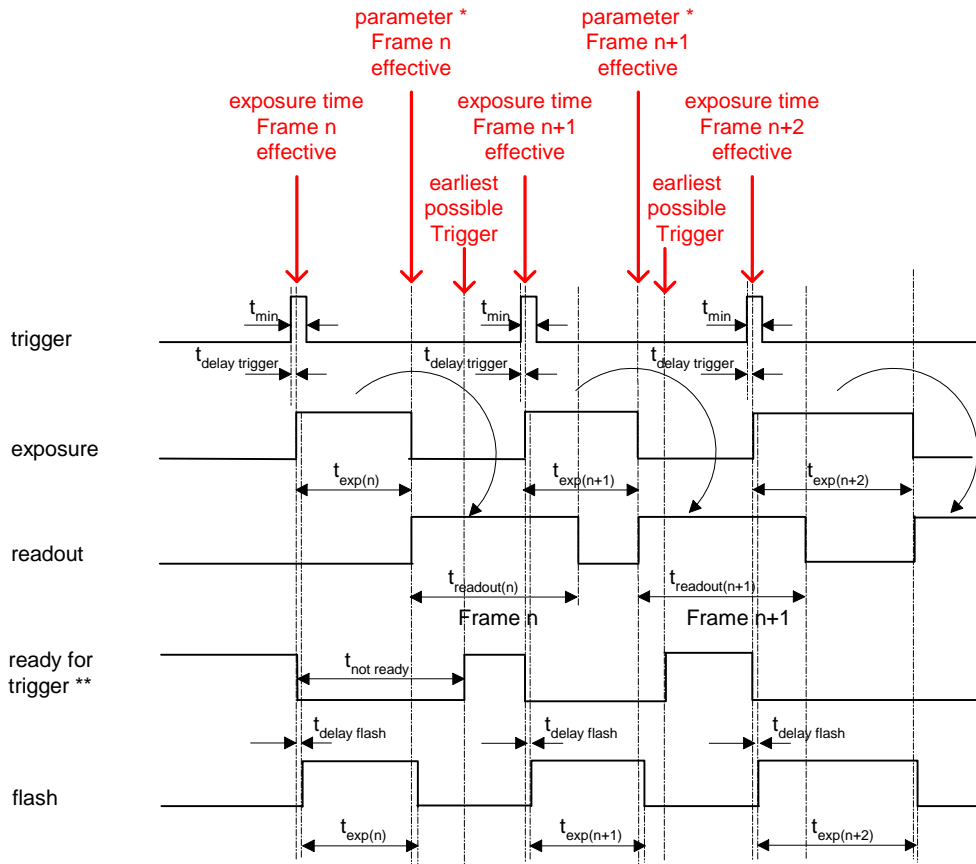

$$t_{exp} < t_{readout}: t_{earliest\ possible\ trigger\ (n+1)} = t_{readout(n)} - t_{exp(n+1)}$$

$$t_{exp} > t_{readout}: t_{earliest\ possible\ trigger\ (n+1)} = t_{exp(n)}$$

$$t_{exp} < t_{readout}: t_{not\ ready\ (n+1)} = t_{exp(n)} + t_{readout(n)} - t_{exp(n+1)}$$

$$t_{exp} > t_{readout}: t_{not\ ready\ (n+1)} = t_{exp(n)}$$

\* image parameter:    offset  
                               global gain  
                               mode  
                               partial scan

\*\* signal will be notified as event "TriggerReady"

Trigger Mode: trigger mode 0, overlapped trigger , when  $t_{exp(n+2)} < t_{exp(n+1)}$

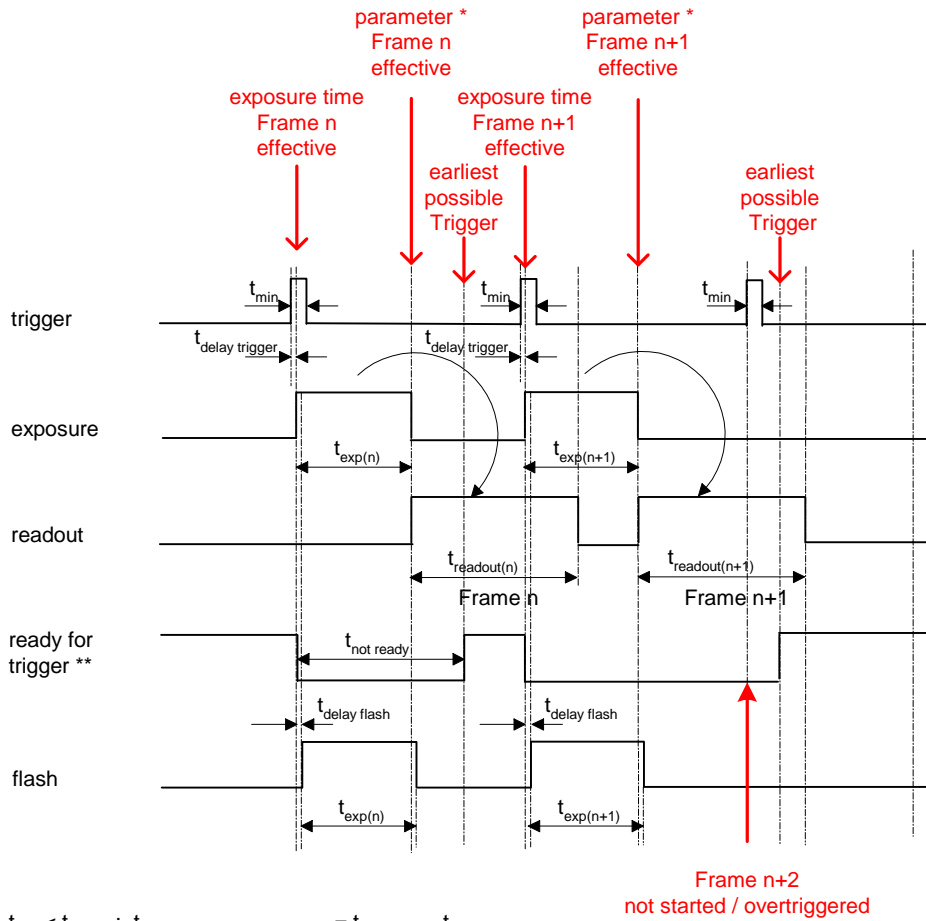

$$t_{exp} < t_{readout} : t_{earliest\ possible\ trigger\ (n+1)} = t_{readout(n)} - t_{exp(n+1)}$$

$$t_{exp} > t_{readout} : t_{earliest\ possible\ trigger\ (n+1)} = t_{exp(n)}$$

$$t_{exp} < t_{readout} : t_{not\ ready\ (n+1)} = t_{exp(n)} + t_{readout(n)} - t_{exp(n+1)}$$

$$t_{exp} > t_{readout} : t_{not\ ready\ (n+1)} = t_{exp(n)}$$

\* image parameter: offset  
global gain  
mode  
partial scan

\*\* signal will be notified as event "TriggerReady"



Trigger Mode: overlapped trigger sequence (example for 3 frames per channel with hardware trigger)

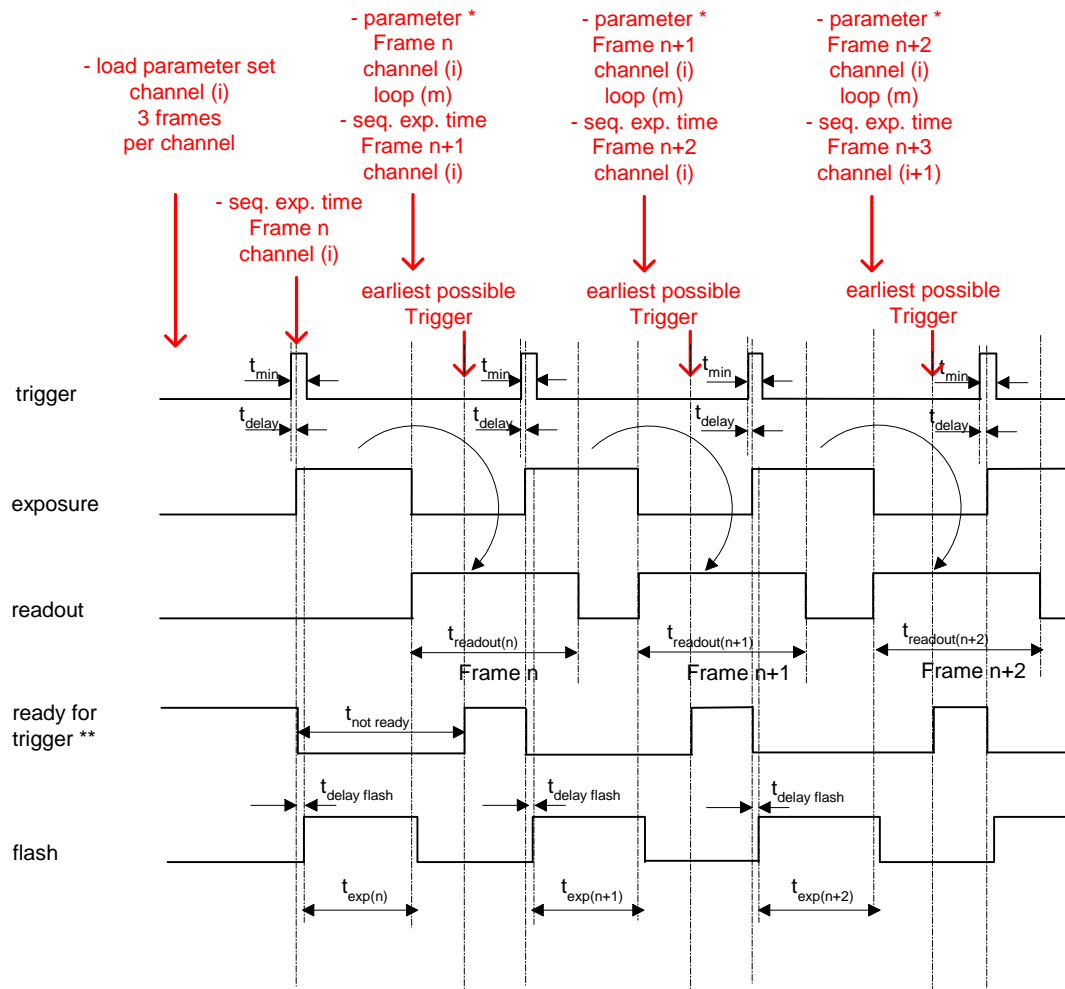

$$t_{exp} < t_{readout}: t_{earliest\ possible\ trigger\ (n+1)} = t_{readout(n)} - t_{exp(n+1)}$$

$$t_{exp} > t_{readout}: t_{earliest\ possible\ trigger\ (n+1)} = t_{exp(n)}$$

$$t_{exp} < t_{readout}: t_{not\ ready\ (n+1)} = t_{exp(n)} + t_{readout(n)} - t_{exp(n+1)}$$

$$t_{exp} > t_{readout}: t_{not\ ready\ (n+1)} = t_{exp(n)}$$

\* image parameter: offset  
sequence global gain  
mode

\*\* signal will be notified as event "TriggerReady"

Free Running Mode: overlapped operation

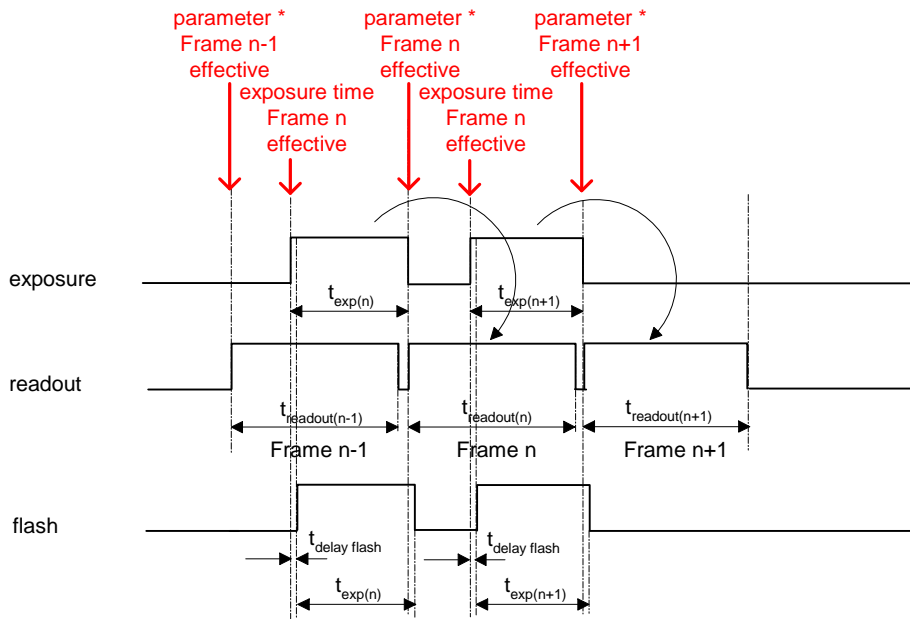

\* image parameter: offset  
 global gain  
 mode  
 partial scan

### 4. Housing

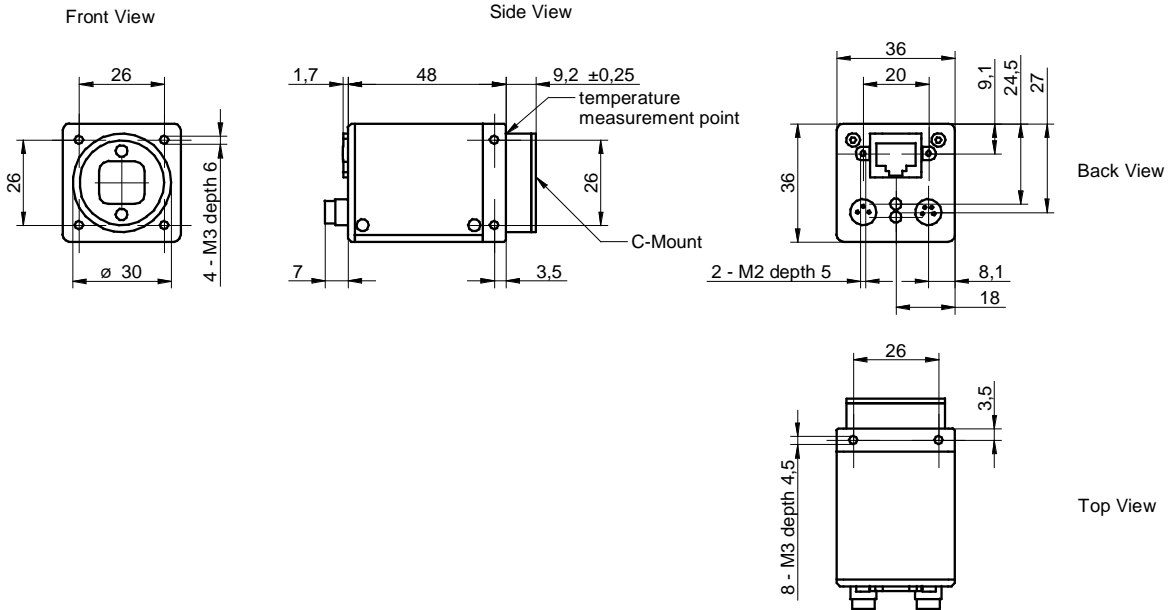

### 5. Connectors / Electrical Interfaces

#### 5.1 Pin assignment:

<b>Data / Control</b> <b>1000 Base-T</b>	Type: RJ45 8P8C mod jack
	<ul style="list-style-type: none"> <li>1: MX1+</li> <li>2: MX1-</li> <li>3: MX2+</li> <li>4: MX3+</li> <li>5: MX3-</li> <li>6: MX2-</li> <li>7: MX4+</li> <li>8: MX4-</li> </ul>

<b>Power</b>	Type: Lumberg RSME5D / 3 pin
	<ul style="list-style-type: none"> <li>1: Power VCC+</li> <li>3: Power GND</li> <li>4: not used</li> </ul>
	Power cable wires color: 1 = brown 3 = blue 4 = black

<b>Trigger / Flash</b>	Type: Lumberg RSME5D 4pin.
	*) resistor must be used, $I_{OUT} = 16 \text{ mA}$ by $U_{EXT} = 24 \text{ VDC}$ recommended, drawing shown above example for using high active signal
	Trigger / Flash cable wires color *): 1 = brown 2 = white 3 = blue 4 = black

\*) shielded trigger / flash cable should be used and ordered separately

5.2 Flash sync sample  $U_{EXT} = 24 \text{ VDC}$  high active:

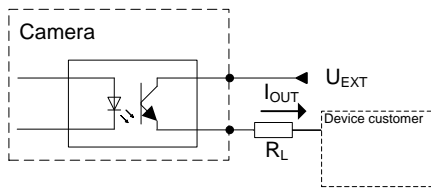

Timing example:  
 measurement condition  $U_{EXT} = 24 \text{ VDC} / I_{OUT} = 16 \text{ mA}$   
 $R_L = 1.5 \text{ kOhm}$

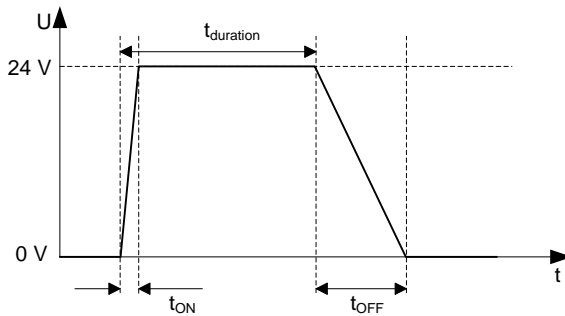

$t_{ON}$  time = typ. 2  $\mu\text{sec}$   
 $t_{OFF}$  time = typ. 40  $\mu\text{sec}$

5.3 Flash sync sample  $U_{EXT} = 24 \text{ VDC}$  low active:

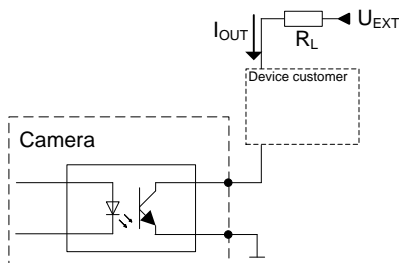

Timing example:  
 measurement condition  $U_{EXT} = 24 \text{ VDC} / I_{OUT} = 16 \text{ mA}$   
 $R_L = 1.5 \text{ kOhm}$

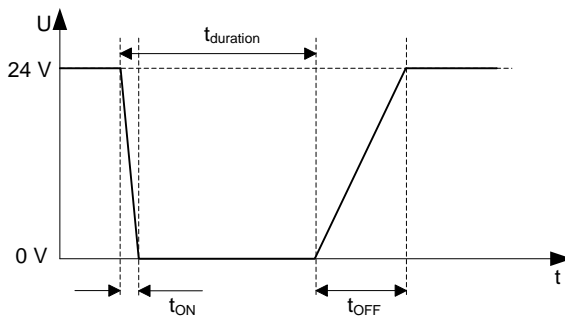

$t_{ON}$  time = typ. 2  $\mu\text{sec}$   
 $t_{OFF}$  time = typ. 40  $\mu\text{sec}$