

**Digital Color
Progressive Scan Camera**

 System: **Gigabit Ethernet**

Baumer TXG02c

Revision 2.1

Art. No: 11075327

- Gigabit Ethernet progressive scan CCD camera
- 656 x 490 pixel
- Up to 140 full frames per second
- GigE Vision[®] standard compliant
- On board integrated color processor for high quality color calculation
- Outstanding image quality
- High sensitivity and dynamic range
- High quality slow scan mode for lowest readout noise
- True partial scan function (ROI) for increased frame rates
- External synchronization via industrial compliant process interface (trigger / flash)
- Integrated supplementary function for flexible integration
- Jumbo frames supported
- Integrated 32 MByte RAM for temporarily image data buffering
- Camera parameter programmable in real-time
- Ultra compact and lightweight aluminum housing
- Standard RJ45 connector
- Screw-lock type industrial connector
- Baumer-GAPI: Flexible, generic software interface for Windows / Linux



1. Overview

Model Name	TXG02c
Sensor	1/4" interline progressive scan CCD EXview HAD technology
Shutter / readout mode	global shutter / progressive scan readout
Number of pixel	656 x 490
Scan area	4.46 mm x 3.80 mm
Pixel size	5.6 µm x 5.6 µm
Color filter	RGB Bayer mosaic
Operation modes	
Trigger mode	yes, overlapped operation
Free running mode	yes, overlapped operation
Signal processing	real-time software programmable
Pixel clock	60 MHz fast scan / 30 MHz high quality (HQ) scan
A/D converter	12 bit
Exposure control (t _{exp})	total: 4 µsec .. 60 sec step: 1 µsec
Gain control	0 .. 20 dB
Offset (black level)	0 .. 1023 LSB (14 bit)
Image data buffer	max. 31 images

Technical specifications subject to change

Image acquisition							
Camera image format modes	Format (pixel)	GenCam standard	Format ID	Pixel format	Pixel clock MHz	Frames per sec. *)	t _{readout}
Full frame HQ slow	656 x 490	Vendor specific	00	BayerRG8	30	70	15 msec
				BayerRG12			
				Mono8			
				YUV411 Packed			
				YUV422 Packed **)			
				YUV444 Packed			
				RGB8 Packed			
Full frame fast	656 x 490	yes	01	BayerRG8	60	140	8 msec
				BayerRG12			
				Mono8			
				YUV411 Packed			
				YUV422 Packed **)			
				YUV444 Packed			
				RGB8 Packed			
BGR8 Packed							
Standard features							
Image size controls							
Pixel format	BayerRG8, BayerRG12, Mono8, YUV411 Packed, YUV422 Packed, YUV444 Packed, RGB8 Packed, BGR8 Packed						
Test image selector	yes, in all modes Off, GreyHorizontalRamp, GreyVerticalRamp, HorizontalLineMoving, VerticalLineMoving, HorizontalAndVerticalLineMoving						
Partial scan	yes, format freely programmable in all modes						
Analog controls							
Gain	yes						
Black Level (Off set)	yes						
Gamma	no						
Acquisition and Trigger							
Acquisition mode	Continuous						
Acquisition frame rate	yes, ON / OFF (only in freerunning mode) 0 .. 829 Hz, step: 0.01 Hz						
Trigger source	HardwareTrigger (Line0), SoftwareTrigger, CommandTrigger (ActionCommand), All or Off						
Trigger delay	0 .. 2 sec, 512 trigger can be tracked, step: 1 µsec						
Sequencer	no						
Digital I/O							
Lines	Input: Line0, Output: Line1						
Line source (outputs only)	Line1: Off, ExposureActive, Timer1, ReadoutActive, User0, TriggerReady, TriggerOverlapped, TriggerSkipped						
Line debouncer	yes, low and high signal separately selectable 0 .. 5 msec step: 1 µsec						
Event Generation							
Events	GigEVisionError, Heartbeattimeout, EventLost, Line0RisingEdge, Line0FallingEdge, Line1RisingEdge, Line1FallingEdge, ExposureStart, ExposureEnd, FrameStart, FrameEnd, TriggerReady, TriggerOverlapped, TriggerSkipped						
Event Notification	yes, ON / OFF						
Counters and Timers							
Framecounter	yes, 2 ³² can be set by user						
Timer	yes, TimerSelector: Timer1 TimerTriggerSource: Off, Input: Line0, SoftwareTrigger, CommandTrigger (ActionCommand), ExposureStart, ExposureEnd, FrameStart, FrameEnd, TriggerSkipped TimerDelay: 0 µsec .. 2 sec, step: 1 µsec TimerDuration: 10 µsec .. 2 sec, step: 1 µsec						

LUT Controls			
LUT selector	no		
Defect pixel correction (custom)	yes, ON / OFF		
Defect pixel list (custom)	yes, max. 256 pixel coordinates (x, y) can be stored		
GigEVisionTransportLayer			
PayLoadsize	4 Byte .. 648.400 Byte		
TransmissionDelay (custom)	0 .. 2 ³² -1 ticks		
UserSets			
User set selector	Default (factory settings / read only) UserSet1, UserSet2, UserSet3 (read and write)		
UserSetDefaultSelector	yes, define the start up "UserSet"		
Advanced features			
Time stamp function	yes, 64 bit tick = 32 nsec		
Asynchronous message channel	yes		
Concatenation function	yes		
User defined identifier	yes, user programmable permanent identifier		
ActionCommand	yes, ID 0 = Trigger		
DeviceTemperature	no		
Data quality			
at 20 °C, gain = 1, exposure time = 32 msec, full frame mode, slow scan			
Readout noise	$\sigma < 0.5$ LSB (8 bit) typical		
Dynamic range	typical > 54 dB		
Optical interface			
C-Mount on request: CS-Mount			
Optical filter	Hoya E-CM500S on request: dust protection, daylight filter or no filter		
Process interface functions			
Async. Trigger	yes, trigger mode operation, "Off", "software trigger", "hardware trigger", "command trigger" or "all" separately selectable (overtriggered signals and trigger signals during the readout time will be notified in the received image header)		
Exposure Active (External flash sync)	yes, delay_value ($t_{\text{delay flash}}$) ≤ 4 μsec , duration_value (t_{duration}): slow mode = $t_{\text{exp}} + 28$ μsec fast mode = $t_{\text{exp}} + 14$ μsec		
User Output	yes, ON / OFF		
Timer	yes, Timer1		
Software reset	yes, delay up to 102 msec		
Asynchronous reset	Full frame	slow fast	delay up to 2,5 msec 1,3 msec
Image info header	yes		
Electrical interface			
Data / control	standard single cable 1000 Base-T, Cat6 recommended / minimum Cat5e option: screw lock type connector		
Power	VCC: 8 VDC .. 30 VDC I: 450 mA .. 120 mA		
Power consumption	approx. 3.6 Watt		
Digital input	Line 0: trigger signal, opto decoupled $U_{\text{IN(low)}} = 0 \dots 4.5$ VDC, $U_{\text{IN(high)}} = 11 \dots 30$ VDC $I_{\text{IN}} = 6 \dots 10$ mA / 7 mA typical rising edge (invert = false) **** min. impulse length (t_{min}): 2 μsec trigger delay out of t_{readout} ($t_{\text{delay trigger}}$): 1 μsec max. trigger delay during t_{readout} ($t_{\text{delay trigger}}$): slow mode = 28 μsec fast mode = 14 μsec		
Digital output	Line 1: opto decoupled $U_{\text{EXT}} = 5 \dots 30$ VDC / 24 VDC typical, $I_{\text{OUT}} = \text{max. } 16$ mA high active (invert = false) ****		
LED	1: green: yellow: 2: green: green flash: yellow: yellow/red flash:	Power on Readout active Link Phy (1 GBit) Ethernet RX Ethernet TX Ethernet RX/TX	

Technical specifications subject to change

Environmental	
Storage temperature	-10 °C .. +70 °C
Operating temperature	+5 °C .. +50 °C ****) between +26 °C .. +50 °C, note the max. housing temperature
Housing operating temperature	max. +50 °C
Humidity	10 % .. 90 % non condensing
Conformity	CE, FCC Part 15 class B, UL, RoHS compliant
Housing	aluminum, IP40
Dimensions	36 x 36 x 48 mm ³
Weight	< 90 g
1000 Base-T interface	1000BASE-T (1000 Mbit / sec)
Ethernet IP configuration	persistent IP / DHCP / LLA
Stream channel packet size	576 Byte (default) .. 65535 Byte jumbo frames supported
Interpacketgap	0 .. 2 ³² -1 ticks
Multicast function	yes
Resend function	yes
Software	Baumer-GAPI SDK with supported OS socket driver and Baumer filter driver / SDK for Windows XP (32 bit) / Windows Vista (32 bit / 64 bit) / Windows 7 (32 bit / 64 bit) / Linux Kernel 2.6.xx (64 bit / 32 bit)
	GigE Vision [®] compatible programs and image processing libraries supported Windows / Linux depending on the actually driver software is used

- *) maximum frame rate in free running mode, effective frame rate depending on camera image format mode settings and set exposure time ($t_{exp} < t_{readout}$)
- ***) default pixel format
- ****) can be inverted via software
- *****) housing temperature is limited by CCD sensor specification

2. Camera Factory Settings after Camera Start-up

Camera factory settings after camera start-up	
Operation modes	free running mode
Signal processing	
Exposure control	32 msec
Gain control	factor 1 = 0 dB
Offset (black level)	0
Image acquisition	
Camera image format mode	mode id = 01, full frame YUV422 Packed
Partial scan function	not active
Acquisition frame rate	Off
Timer	Off
Transmission delay	0 ticks
Test image selector	Off
Defect pixel correction	On
Electrical interface	
Digital input	1: Line0 disabled, digital output set to low status (high impedance) invert = false line source = Exposure Active
Digital output	1: Line1 disabled invert = false trigger source = Line0

3. Timing Operation Modes

Trigger Mode: start up time

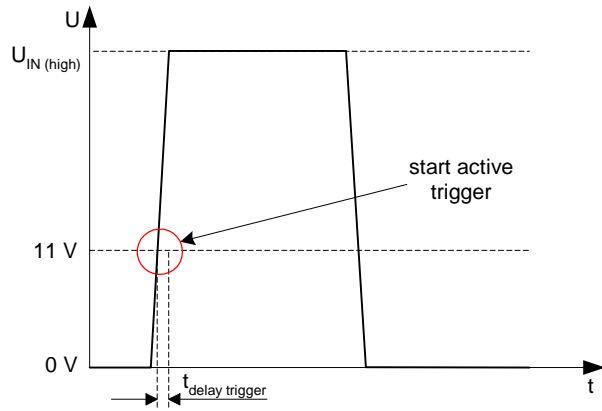

Trigger Mode: trigger mode 0, overlapped trigger

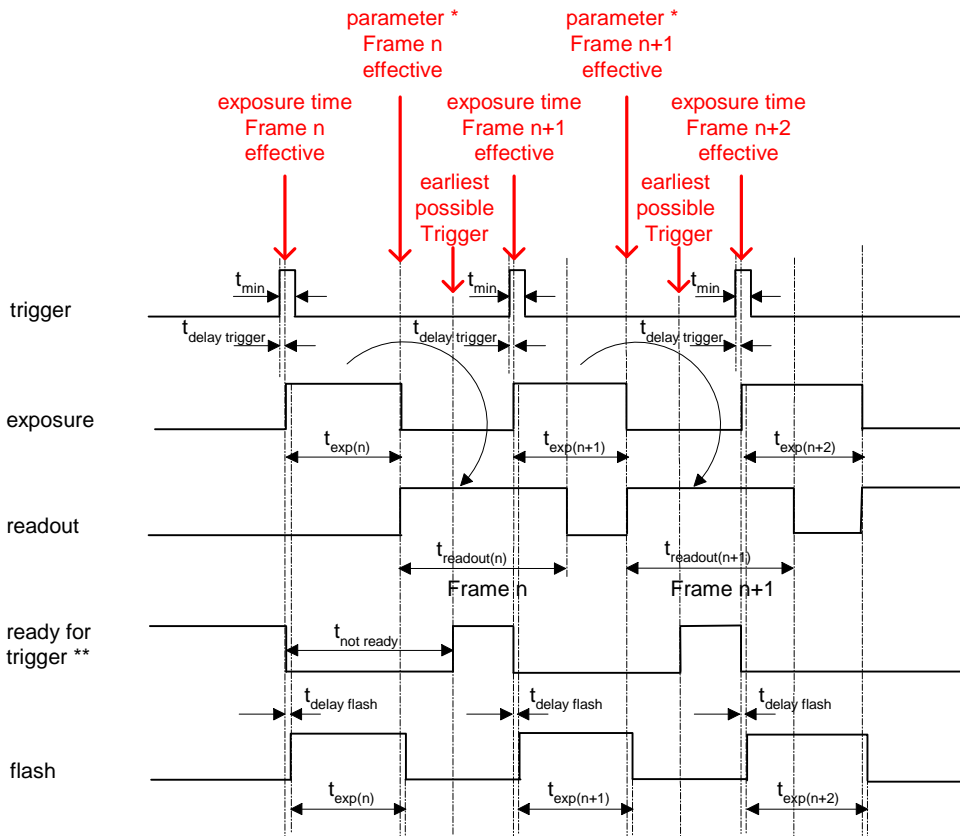

$$t_{exp} < t_{readout}: t_{\text{earliest possible trigger (n+1)}} = t_{readout(n)} - t_{exp(n+1)}$$

$$t_{exp} > t_{readout}: t_{\text{earliest possible trigger (n+1)}} = t_{exp(n)}$$

$$t_{exp} < t_{readout}: t_{\text{not ready (n+1)}} = t_{exp(n)} + t_{readout(n)} - t_{exp(n+1)}$$

$$t_{exp} > t_{readout}: t_{\text{not ready (n+1)}} = t_{exp(n)}$$

* image parameter: offset
 global gain
 mode
 partial scan

** signal will be notified as event "TriggerReady" and is not available as digital output

Trigger Mode: trigger mode 0, overlapped trigger , when $t_{exp(n+2)} > t_{exp(n+1)}$

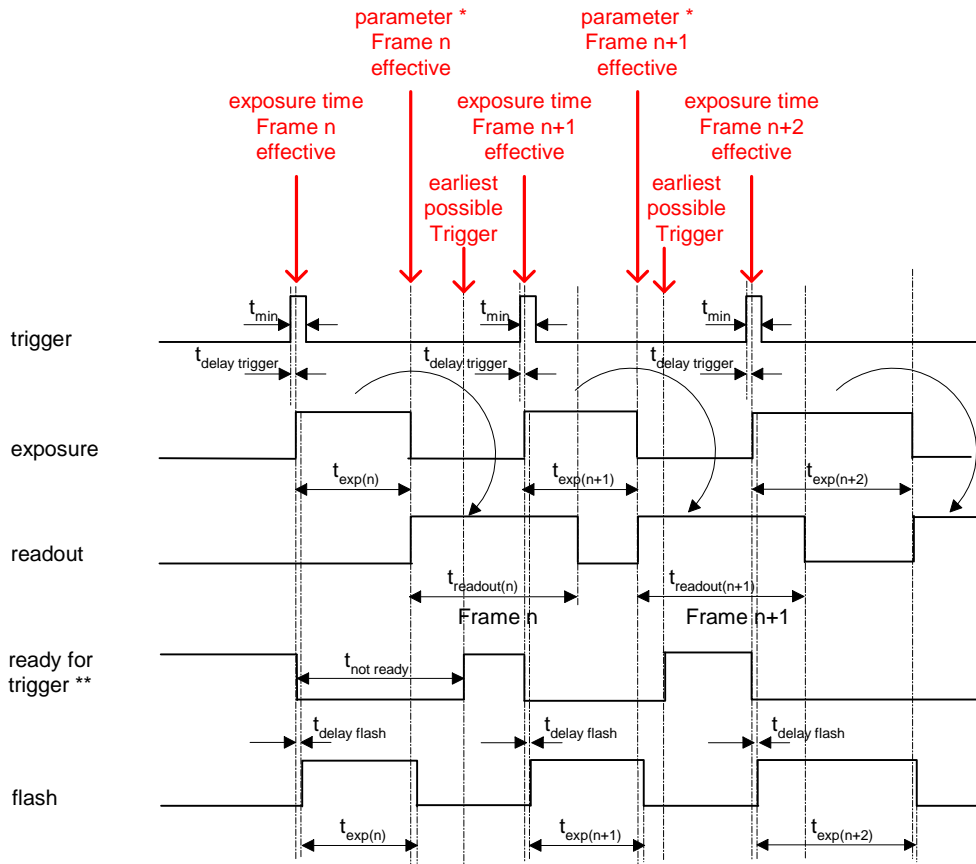

$$t_{exp} < t_{readout}: t_{earliest\ possible\ trigger\ (n+1)} = t_{readout(n)} - t_{exp(n+1)}$$

$$t_{exp} > t_{readout}: t_{earliest\ possible\ trigger\ (n+1)} = t_{exp(n)}$$

$$t_{exp} < t_{readout}: t_{not\ ready\ (n+1)} = t_{exp(n)} + t_{readout(n)} - t_{exp(n+1)}$$

$$t_{exp} > t_{readout}: t_{not\ ready\ (n+1)} = t_{exp(n)}$$

* image parameter: offset
 global gain
 mode
 partial scan

** signal will be notified as event "TriggerReady" and is not available as digital output

Trigger Mode: trigger mode 0, overlapped trigger , when $t_{exp(n+2)} < t_{exp(n+1)}$

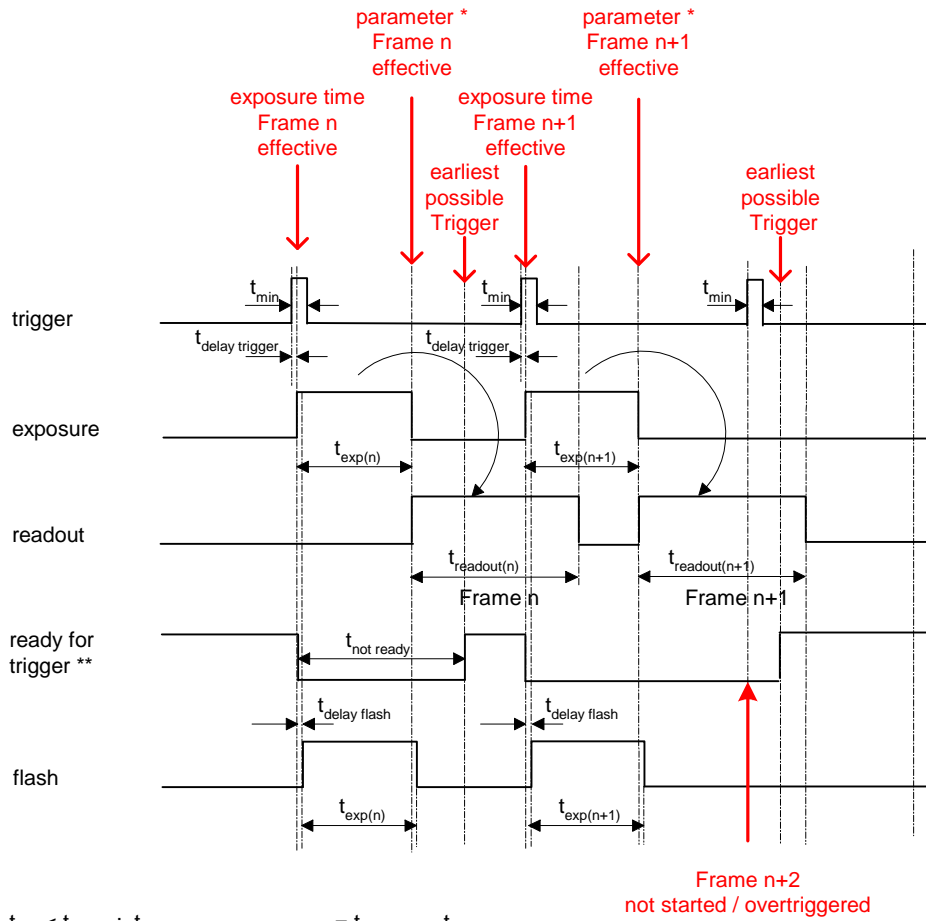

$$t_{exp} < t_{readout} : t_{earliest\ possible\ trigger\ (n+1)} = t_{readout(n)} - t_{exp(n+1)}$$

$$t_{exp} > t_{readout} : t_{earliest\ possible\ trigger\ (n+1)} = t_{exp(n)}$$

$$t_{exp} < t_{readout} : t_{not\ ready\ (n+1)} = t_{exp(n)} + t_{readout(n)} - t_{exp(n+1)}$$

$$t_{exp} > t_{readout} : t_{not\ ready\ (n+1)} = t_{exp(n)}$$

* image parameter: offset
global gain
mode
partial scan

** signal will be notified as event "TriggerReady" and is not available as digital output

Free Running Mode: overlapped operation

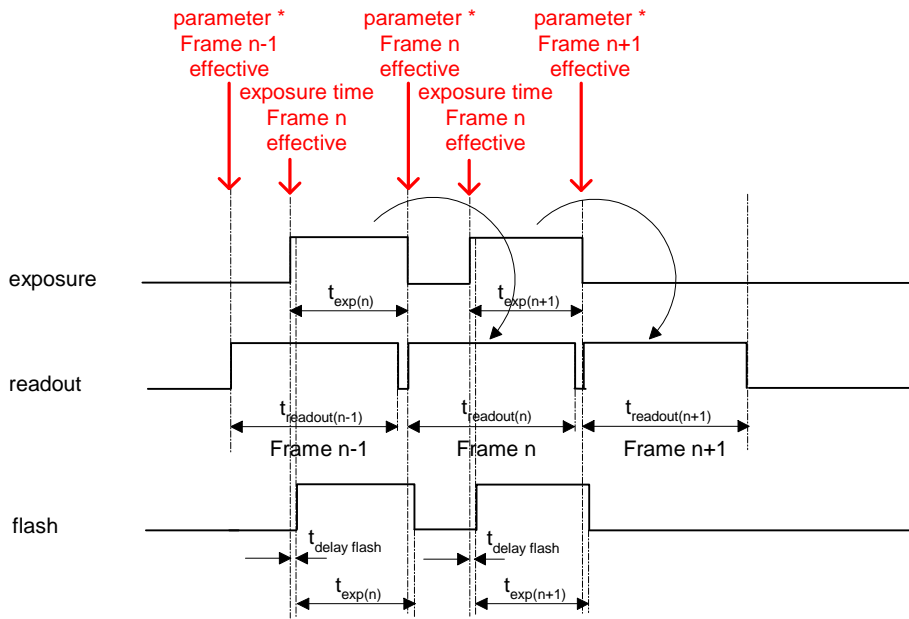

* image parameter: offset
 global gain
 mode
 partial scan

4. Housing

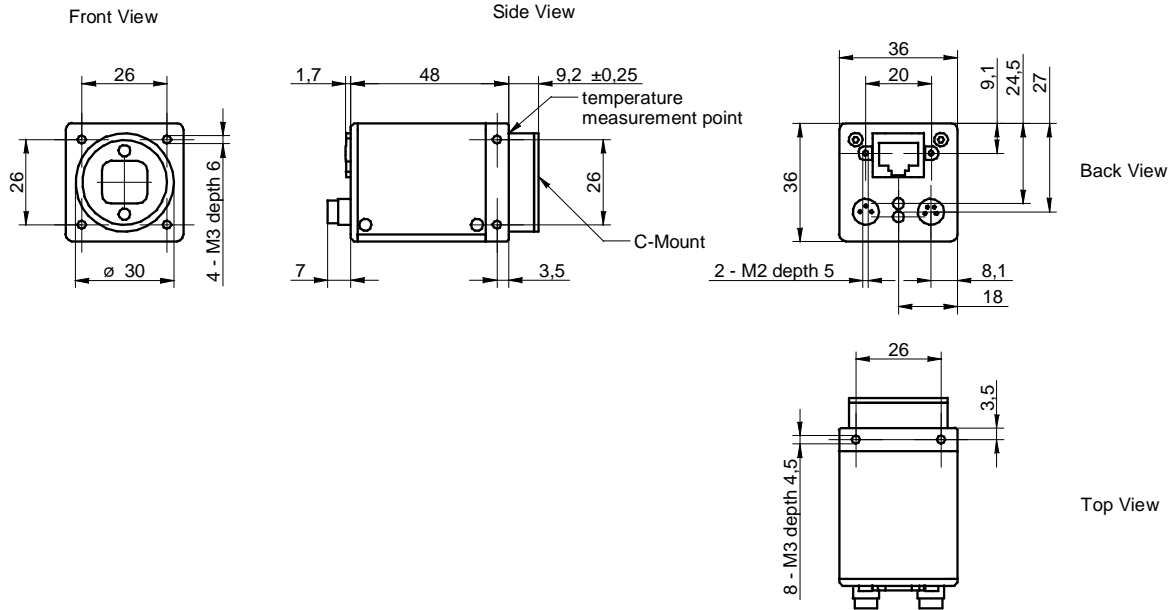

5. Connectors / Electrical Interfaces

5.1 Pin assignment:

Data / Control 1000 Base-T	Type: RJ45 8P8C mod jack
	<ul style="list-style-type: none"> 1: MX1+ 2: MX1- 3: MX2+ 4: MX3+ 5: MX3- 6: MX2- 7: MX4+ 8: MX4-

Power	Type: Lumberg RSMESD / 3 pin
	<ul style="list-style-type: none"> 1: Power VCC+ 3: Power GND 4: not used
	Power cable wires color: 1 = brown 3 = blue 4 = black

Trigger / Flash	Type: Lumberg RSMESD 4pin.
	*) resistor must be used, $I_{OUT} = 16 \text{ mA}$ by $U_{EXT} = 24 \text{ VDC}$ recommended, drawing shown above example for using high active signal
	Trigger / Flash cable wires color *): 1 = brown 2 = white 3 = blue 4 = black

*) shielded trigger / flash cable should be used and ordered separately

5.2 Flash sync sample $U_{EXT} = 24 \text{ VDC}$ high active:

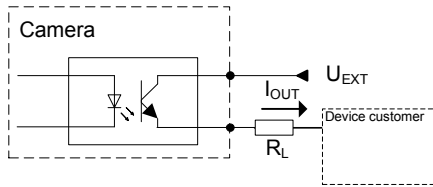

Timing example:
 measurement condition $U_{EXT} = 24 \text{ VDC} / I_{OUT} = 16 \text{ mA}$
 $R_L = 1.5 \text{ kOhm}$

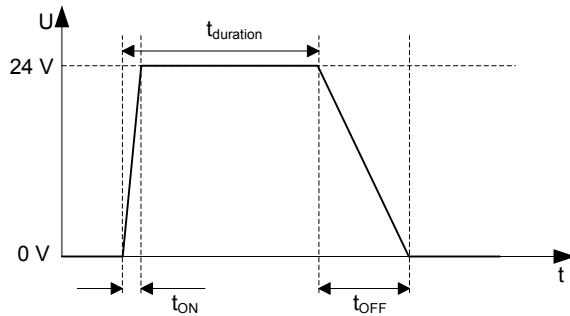

t_{ON} time = typ. $2 \mu\text{sec}$
 t_{OFF} time = typ. $40 \mu\text{sec}$

5.3 Flash sync sample $U_{EXT} = 24 \text{ VDC}$ low active:

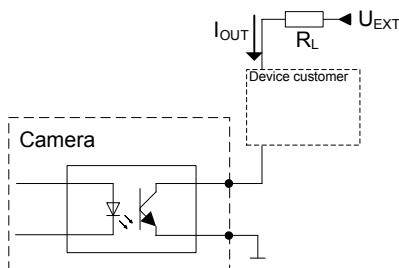

Timing example:
 measurement condition $U_{EXT} = 24 \text{ VDC} / I_{OUT} = 16 \text{ mA}$
 $R_L = 1.5 \text{ kOhm}$

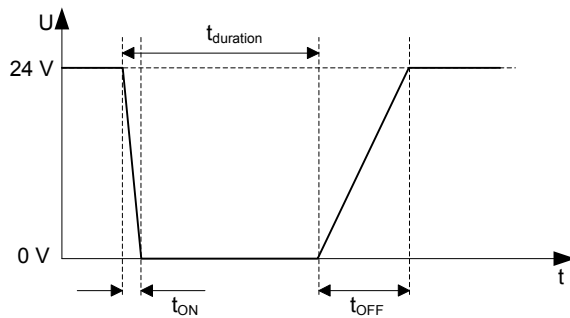

t_{ON} time = typ. $2 \mu\text{sec}$
 t_{OFF} time = typ. $40 \mu\text{sec}$