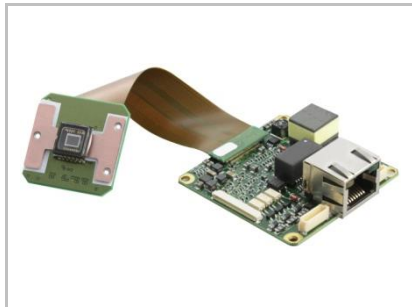

MXG02

Technical Data

 Art. No.
11094926

Digital Monochrome Matrix Camera Module, Gigabit Ethernet

Sensor Information

Model Name	SONY ICX618
Type	1/4" progressive scan CCD, EXview HAD technology
Shutter	Global
Native Resolution	656 x 490 pixels
Scan Area	3.67 mm x 2.74 mm
Pixel Size	5.6 μm x 5.6 μm

Data Quality

@ 20 °C, gain = 1, exposure time = 32 msec

Readout Noise (σ)	0.2 LSB @ 8 bit, 3.5 LSB @ 12 bit (typical)
Dynamic Range	61 dB (typical)

Acquisition Formats

Image Formats	Format	Resolution	Frame Rate	t_{readout}
	Full Frame	656 x 490	160 fps	6.25 msec
Pixel Formats	Mono8, Mono12, Mono12 Packed			
Partial Scan	True Partial Scan, Region of Interest (ROI) arbitrary			

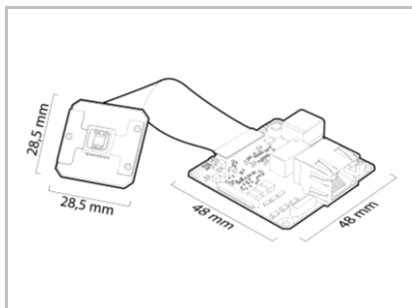
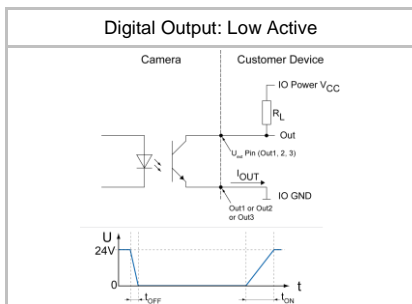
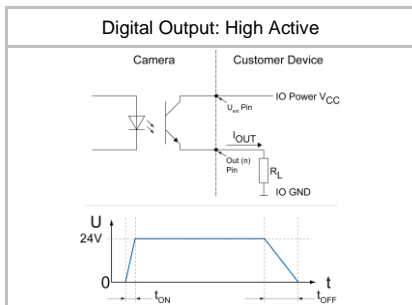
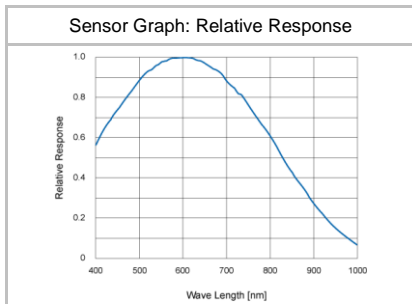

Image Pre-Processing

Analog Controls	Exposure Time (4 μsec ... 60 sec Step Size 1 μsec) Gain (0 ... 29 dB), Offset (0 ... 1023 LSB 14 bit),
Gamma Correction	Gamma (0.1 ... 2 available if LUT is enabled)
LUT	Luminance (12 bit)
Color Models	Mono
Color Tolerance	Only on Color Cameras
Color Processing	Only on Color Cameras
Color Adjustment	Only on Color Cameras
Binning Horizontal	1 or 2
Binning Vertical	1 or 2
Image Flipping	Horizontal
Defect Pixel Correction	via Defect Pixel List with up to 511 Pixel Coordinates



Process Synchronization

Modes	Free Running, Trigger
Free Running	Continuous or Adjustable Acquisition Frame Rate ¹ (0.01 ... 1072 Hz)
Trigger Sources	Hardware, Software, ActionCommand, All or Off
Trigger Delay	0 ... 2 sec, Tracking and buffering of up to 512 triggers
Sequencer Characteristics	up to 128 sets of parameters, up to 65536 loop passes, up to 65536 repetitions of sets of parameters, up to 65536 images per trigger event
Sequencer Parameters	Exposure Time, Gain Factor, Output Line, ROI Offset x, ROI Offset y
External Flash Sync	via Exposure Active $t_{\text{delay flash}} \leq 3 \mu\text{sec}$, $t_{\text{duration}} = t_{\text{exposure}}$

Digital I/Os

Lines	Input: Line 0, Output: Line1, Line 2, Line 3
Circuit Times	Output: $t_{\text{ON}} = \text{typ. } 3 \mu\text{sec}$ $t_{\text{OFF}} = \text{typ. } 40 \mu\text{sec}$
Output Sources	Off, ExposureActive, Line 0, Timer1 ... 3, ReadoutActive, User1 ... 3, TriggerReady, TriggerOverlapped, TriggerSkipped, Sequencer Output 0 ... 2
Line Debouncer	Low and high signal separately selectable Debouncing Time 0 ... 5 msec, Step Size: 1 μsec

¹ Max. Acquisition Frame Rate can be achieved by using the following camera settings: min. Exposure + max. Binning + ROI | min. Size Y + Mono8

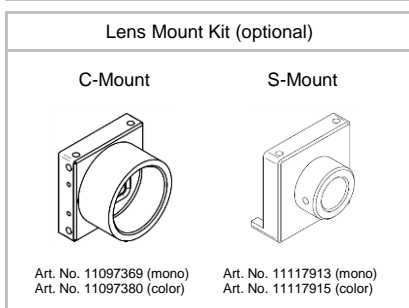
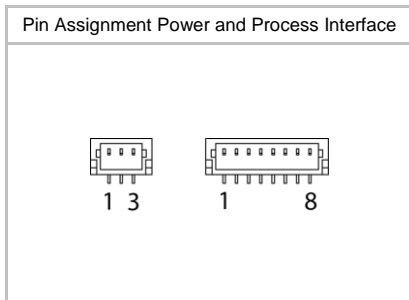
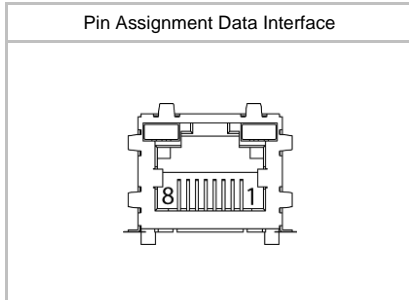
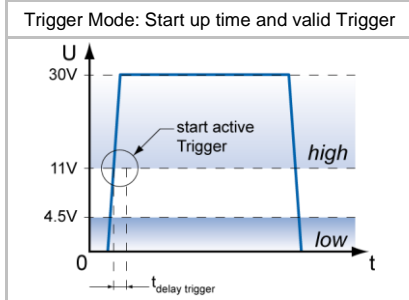
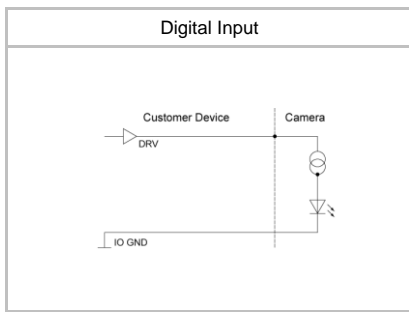

Interfaces and Connectors

Data Interface	Gigabit Ethernet	Transfer Rate	1000 Mbits/sec
	Fast Ethernet	Transfer Rate	100 Mbits/sec
	Connector:	8P8C Modular Jack (RJ45)	
	Pin Assignment:	1 – MX1+	5 – MX3-
		2 – MX1-	6 – MX2-
		3 – MX2+	7 – MX4+
		4 – MX3+	8 – MX4-
Process Interface	Connector:	JST BM08B-SRSS-TB	
	Assignment:	1 – Shielding	5 – OUT 2
		2 – IN1	6 – OUT 3
		3 – IO GND	7 – IO Power VCC
		4 – OUT 1	8 – Shielding
Power Interface	Connector:	JST BM03B-SRSS-TB	
	Assignment:	1 – Shielding	
		2 – Power VCC+	
		3 – Power GND	

Mechanical Data

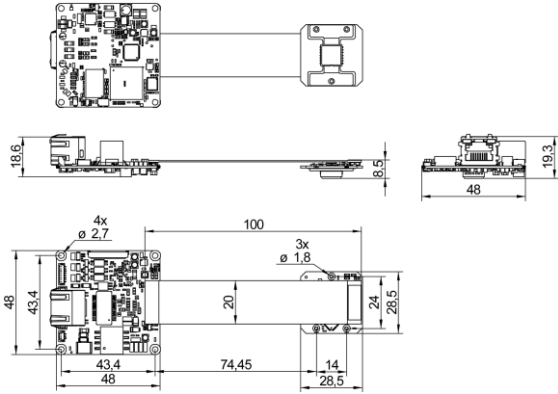
Housing	Board Level Module without Housing
Dimensions	
Weight	30 g (without Optics Adapter)

Optical Data

Lens Mount	C-Mount (Adapter), S-Mount (Adapter)
Optical Filter	Dust Protection Glass

Electrical Data

Power Supply (ext.)	VCC:	12... 24 V DC ± 20%
	I:	139 ... 269 mA
Power over Ethernet	Class 0 device	
	VCC:	36 ... 57 V DC
	I:	77 mA @ 48 VDC
Power Consumption	approx.	3.4 W @ 12 VDC and 160 fps
	approx.	3.7 W @ 48 VDC (PoE) and 160 fps
Digital Input	$U_{IN(low)}$:	0.0 ... 4.5 VDC
	$U_{IN(high)}$:	11.0 ... 30.0 VDC
	I_{IN} :	6.0 ... 10 mA
	min. Impulse Length:	2.0 µsec
	Trigger Delay out of treadout:	1.0 µsec
	max. Trigger Delay during treadout:	14.0 µsec
Digital Output	U_{EXT} :	5 ... 30 V DC
	I_{OUT} :	max. 50 mA

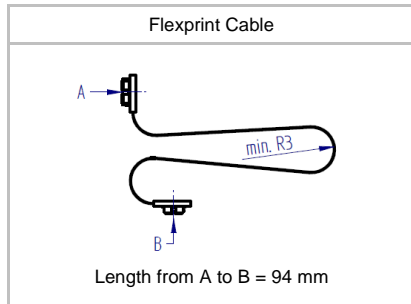
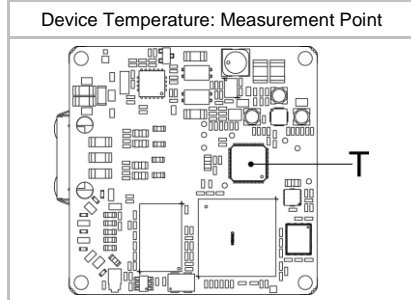
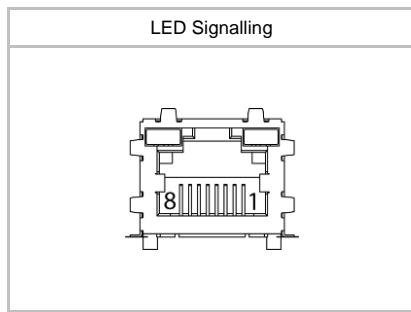

LED Signalling

LED 1 (right)	Green	Link active
	Green flash	Receiving
LED 2 (left)	Yellow	Transmitting

Environmental Data

Storage Temperature	-10 °C bis +70 °C
Operating Temperature	Depends on the thermal encapsulation
Device Temperature	T _{max} = 70 °C @ Measurement Point
Humidity	10 % ... 90 % non-condensing
Conformity	RoHs, REACH

Network Interface Data

Network Interface	Gigabit Ethernet	1000BASE-T	1000 Mbits/sec
	Fast Ethernet	100 BASE-T	100 Mbits/sec
Ethernet IP Configuration	Persistent IP, DHCP, LLA		
Packet Size	576 ... 16 KByte, Jumbo Frames supported		

GigE Vision® Features (in compliance with GigE Vision® 1.2)

Events	PrimaryApplicationStitch, GigEVisionError, GigEVisionHeartbeatTimeOut, EventLost, EventDiscarded, Line0RisingEdge, Line0FallingEdge, Line1RisingEdge, Line1FallingEdge, Line2RisingEdge, Line2FallingEdge, Line3RisingEdge, Line3FallingEdge, ExposureStart, ExposureEnd, FrameStart, FrameEnd, TriggerReady, TriggerOverlapped, TriggerSkipped
Transmission via Asynchronous Message Channel	
Frame Counter	up to 2 ³²
Payload Size	4 ... 643.152 Byte
Transmission Delay	0 ... 2 ³² -1 Ticks (1 Tick = 1 nsec)
Timestamp	64 bit
Packet Delay	0 ... 2 ³² -1 Ticks
Packet Resend	Resend Buffer: 120 MB (30 Images)

GenICam™ Features (in compliance with SFNC 1.5.1)

Timer	Timer Selector: Timer 1 ... 3 TimerTriggerSource: Line0, SoftwareTrigger, CommandTrigger, ExposureStart, ExposureEnd, FrameStart, FrameEnd, TriggerSkipped, Off TimerDelay: 0 µsec ... 2 sec, Step Size: 1 µsec TimerDuration: 10 µsec ... 2 sec, Step Size: 1 µsec
User Sets	Factory Settings: UserSet0 (read only) Freely Programmable: UserSet1, UserSet2, UserSet3 Parameters: any user definable Parameter
Acquisition Abort	Delay up to 6.3 msec

Factory Settings after Start-Up

Operation Mode	Free Running
Analog Controls	Exposure Time: 4 msec, Gain: 0 dB, Offset: 0
Pixel Format	Mono8
Partial Scan	Off
Acquisition Frame Rate	Off
Timer	Off
Transmission Delay	Off
Defect Pixel Correction	On
Digital Input	Line0, invert = false, trigger source = All
Digital Output	Line1, invert = false, line source = Off