

**Digital Color  
Progressive Scan Camera**

 System: **Dual Gigabit Ethernet**
**Baumer HXG20c / HXG20c-F**

Revision 2.0

 Art. No: **11080595 (C-Mount)**  
**11082533 (F-Mount)**

- Dual Gigabit Ethernet progressive scan CMOS camera
- 2048 x 1088 pixel with up to 105 full frames per second
- Burst mode with up to 337 full frames per second using integrated 256 MByte RAM for temporarily image buffering
- GigE Vision™ standard compliant
- Excellent image quality
- Global shutter architecture for minimized motion blur
- Low noise due to correlated double sampling (CDS)
- True partial scan function (ROI) for increased frame rates
- High Dynamic Range (HDR) image acquisition
- External synchronization via industrial compliant process interface (trigger / flash)
- Integrated supplementary function for flexible integration
- Sequence function up to 2<sup>31</sup>-1 frames per sequence
- Jumbo frames supported
- Camera parameter programmable in real-time
- Static Link Aggregation for higher bandwidth and resilience
- Power over Ethernet support
- Compact and lightweight aluminum housing
- Standard RJ45 connector
- Screw-lock type industrial connector
- Baumer-GAPI: Flexible, generic software interface for Windows / Linux

**1. Overview**

Model Name	HXG20c / HXG20c-F
Sensor	2/3" progressive scan CMOS
Vendor and Model	CMOSIS CMV-2000
Shutter / readout mode	global shutter / progressive scan readout
Number of pixel	2048 x 1088
Scan area	11.26 mm x 5.98 mm
Pixel size	5.5 µm x 5.5 µm
Color filter	RGB Bayer mosaic
<b>Operation modes</b>	
Trigger mode	yes, sequential or overlapped operation
Free running mode	yes, sequential or overlapped operation
Sensor readout channels	16 / 8 / 4 / 2 channel readout
<b>Signal processing</b>	real-time software programmable
Pixel clock	8/10 bit pixel format: 24/40/48 MHz 12 bit pixel format: 20/40 MHz
A/D converter	10 or 12 bit depending on pixel format
Internal exposure control (t <sub>exp</sub> )	total: 20 µsec .. 1 sec step 1 µsec
Trigger pulse width exposure control	Yes, via all trigger lines
Gain control	0 .. 12 dB
Offset (black level)	0 .. 255 LSB
Image data buffer	max. 110 full resolution images

Technical specifications subject to change

Image acquisition							
Camera image format modes	Format (pixel)	Gen<b>Cam standard	Pixel format	Pixel clock MHz	Frames per sec. (*2)		t <sub>treadout</sub>
					Burst mode	Dual GigE	
Full frame	2048 x 1088	yes	BayerGB8 (*4)	48	337	105	2970 μs
			BayerGB10	48	337	53	2970 μs
			BayerGB12	40	70	53	14140 μs
<b>Standard features</b>							
<b>Image size controls</b>							
Binning horizontal	-						
Binning vertical	-						
Pixel format	BayerGB8, BayerGB10, BayerGB12 (*1)						
Test image selector	yes, in all modes Off, GreyHorizontalRamp, GreyVerticalRamp						
Partial scan (ROI)	yes, format freely programmable in all modes, Step size horizontal: 32 pixels Step size vertical: 1 pixel						
Multi partial scan (Multi ROI)	yes, up to 8 horizontal and vertical regions						
<b>Analog controls</b>							
Gain	-						
Black Level (Off set)	yes						
Gamma	yes, via LUT						
Brightness correction (custom)	-						
<b>Digital controls</b>							
Digital gain	yes, factors 1.0 to 4.0 (*5)						
<b>Acquisition and Trigger</b>							
Acquisition mode	Continuous						
Acquisition frame rate	yes, ON / OFF (only in freerunning mode) 0 .. 21739 Hz, step: 0.01 Hz						
Trigger source	HardwareTrigger (Line0, Line1, Line2), Software, CommandTrigger (ActionCommand), Off						
Trigger delay	0 .. 2 sec, 512 trigger can be tracked, step: 1 μsec						
Sequencer	Up to 2 <sup>31</sup> -1 frames per sequence / one exposure time, one gain value and outputs for each parameter set max. set of sequences: Up to 2 <sup>31</sup> -1 frames x 128 parameter sets						
<b>Digital I/O</b>							
Lines	Input: Line0, Line1, Line2 Output: Line3, Line4, Line5						
Line source (outputs only)	Line3, Line4, Line5: Off, ExposureActive, ExposureEnlarged, ReadoutActive, FrameActive, TransferActive, TriggerReady, TriggerOverLapped, TriggerSkipped, Timer1Active, Timer2Active, Timer3Active, Line0, Line1, Line2, UserOutput0, UserOutput1, UserOutput2, SequencerOutput0, SequencerOutput1, SequencerOutput2						
Line debouncer	yes, low and high signal separately selectable 0 .. 5 msec step: 1 μsec						
Line inverter	yes, Line0 .. Line5, on or off						
<b>Event Generation</b>							
Events	GigEVisionError, Heartbeattimeout, EventLost, Line[0,1,3]RisingEdge, Line[0,1,3]FallingEdge, Software, Action1, ExposureStart, ExposureEnd, FrameStart, FrameEnd, TriggerReady, TriggerOverlapped, TriggerSkipped						
Event Notification	yes, ON / OFF						

<b>Counters and Timers</b>	
Counter	yes, CounterSelector: Counter1, Counter2 CounterEventSource: Off, Input: Line0/Line1/Line2, Software, Action1, ExposureStart, ExposureEnd, FrameStart, FrameEnd, TriggerSkipped CounterResetSource: Off, Input: Line0/Line1/Line2, Software, Action1, ExposureStart, ExposureEnd, FrameStart, FrameEnd, TriggerSkipped
Timer	yes, TimerSelector: Timer1, Timer2, Timer3 TimerTriggerSource: Off, Input: Line0/Line1/Line2, Software, Action1, ExposureStart, ExposureEnd, FrameStart, FrameEnd, TriggerSkipped TimerDelay: 0 µsec .. 2 sec, step: 1 µsec TimerDuration: 10 µsec .. 2 sec, step: 1 µsec
<b>LUT Controls</b>	
LUT selector	1 LUT: Luminance (12 bit), ON / OFF
<b>Image Correction</b>	
Defect pixel correction	yes, ON / OFF
Defect pixel list	yes, additional pixels can be added during the lifetime of the camera
DSNU / PRNU (FPN) correction	yes, ON / OFF, based on offset / factor per column, data set calculated with factory settings during production and stored in camera
<b>GigEVisionTransportLayer</b>	
PayLoadsize	576 Byte .. 4.456.720 Byte
<b>UserSets</b>	
User set selector	Default (factory settings / read only) UserSet1, UserSet2, UserSet3 (read and write)
UserSetDefaultSelector	yes, define the start up "UserSet"
<b>Advanced features</b>	
Image Flip	Horizontal, vertical or both
Time stamp function	yes, 64 bit tick = 1 nsec
Asynchronous message channel	yes
Concatenation function	yes
User defined identifier	yes, user programmable permanent identifier
ActionCommand	yes, ID 0 = Trigger, ID 1 = Timestamp set
High Dynamic Range (HDR)	Yes, piecewise linear response, up to 90 dB
<b>Data quality</b>	
Readout noise	$\sigma < 0.3$ LSB (8 bit) typical
Dynamic range	typical 60 dB
<b>Optical interface</b>	
Optical filter	C-Mount on request: F-Mount Micros UV/IR Cut on request: dust protection, super polished, IR cut filter, daylight filter or no filter
<b>Process interface functions</b>	
Async. Trigger	yes, trigger mode operation, "Off", "software trigger", "hardware trigger", "command trigger" or "all" separately selectable (overtriggered signals and trigger signals during the readout time will be notified in the received image header)
Exposure Active (External flash sync)	yes, delay_value ( $t_{\text{delay flash}}$ ) $\leq 4$ µsec, duration_value ( $t_{\text{duration}}$ ): mode = $t_{\text{exp}} + 30$ µsec
User Output	yes, ON / OFF, UserOutput0, UserOutput1, UserOutput2
Timer	yes, Timer1
Software reset	Yes
Asynchronous reset	-
Image info header	yes
Temperature measurement	-

Technical specifications subject to change

<b>Electrical interface</b>	
Data / control	standard dual cable 1000 Base-T, Cat6 recommended / minimum Cat5e option: screw lock type connector
Power	Dedicated 3 pin power interface VCC: 20 VDC .. 30 VDC, I: 272 mA .. 420 mA
	Power over Ethernet (PoE) Class 0 device (via 1000 Base-T cable) VCC: 48VDC (38 VDC .. 30 VDC) I: 155 mA .. 238 mA, supported by port 1 (at the top)
Power consumption	approx. 7,7 Watt (with camera factory settings)
Digital input	1 / 2 / 3: Line 0 / Line 1 / Line 2: trigger signal, opto decoupled $U_{IN(low)} = 0 \dots 4.5 \text{ VDC}$ , $U_{IN(high)} = 11 \dots 30 \text{ VDC}$ $I_{IN} = \text{max. } 10 \text{ mA}$ rising edge (invert = false) (*6) min. impulse length ( $t_{min}$ ): 2 $\mu\text{sec}$ trigger delay out of $t_{readout}$ ( $t_{delay \text{ trigger}}$ ): 4 $\mu\text{sec}$ max. trigger delay during $t_{readout}$ ( $t_{delay \text{ trigger}}$ ): 30 $\mu\text{sec}$
Digital output	1 / 2 / 3: Line 3 / Line 4 / Line 5: opto decoupled $U_{EXT} = 5 \dots 30 \text{ VDC}$ / 24 VDC typical, $I_{OUT} = \text{max. } 100 \text{ mA}$ high active (invert = false) (***)
LED	1(Camera): green: Power on yellow: Readout active 2(GigE Port 1): green: Link active green flash: Receiving 3(GigE Port 1): yellow: Transmitting 4(GigE Port 2): green: Link active green flash: Receiving 5(GigE Port 2): yellow: Transmitting
<b>Environmental</b>	
Storage temperature	-10 °C .. +70 °C
Operating temperature	+5 °C .. +50 °C
Housing operating temperature	between +15 °C .. +50 °C, note the max. housing and internal temperature max. +50 °C (*7) (measurement point, see item 4)
Humidity	10 % .. 90 % non condensing
Conformity	CE, FCC Part 15 class B, RoHS compliant
<b>Housing</b>	
Aluminum	
Dimensions	52 x 52 x 55 mm <sup>3</sup> (C-Mount) 52 x 52 x 55 mm <sup>3</sup> (F-Mount)
Weight	232 g (C-Mount) 323 g (F-Mount)
<b>1000 Base-T interface</b>	
Ports	2
Ethernet IP configuration	persistent IP / DHCP / LLA
Stream channel packet size	576 Byte (default) .. 65535 Byte jumbo frames supported
Interpacketgap	0 .. 2 <sup>32</sup> -1 ticks
Multicast function	yes
Resend function	Yes
Link aggregation	Yes, according to 802.3ad, static configuration
<b>Software</b>	Baumer-GAPI SDK with supported OS socket driver and Baumer filter driver / SDK for Windows XP (32 bit) / Windows Vista (32 bit / 64 bit) / Windows 7 (32 bit / 64 bit) / Linux Kernel 2.6.xx (64 bit / 32 bit)
	GigE Vision <sup>®</sup> compatible programs and image processing libraries supported Windows / Linux depending on the actually driver software is used

- (\*1) For changing the pixel frequency or the pixel format, the camera has to be stopped.
- (\*2) Maximum frame rate in free running mode, effective frame rate depending on camera image format mode settings and set exposure time ( $t_{exp} < t_{readout}$ ). This assumes 16 tap readout at maximum pixel frequency.
- (\*3) -
- (\*4) Default pixel format
- (\*5) Digital gain is applied on the raw data obtained from the sensor. In 10 and 12 bit modes, this is just a bit shift cutting away the MSBs!
- (\*6) can be inverted via software
- (\*7) housing temperature is limited by CMOS sensor specification  
In warm environments take care of adequate dissipation of heat. It is recommended to operate the cameras in mounted condition with a good heat conductor (e.g. aluminum) or with sufficient air flow.

Technical specifications subject to change

## 2. Camera Factory Settings after Camera Start-up

Camera factory settings after camera start-up or reboot	
<b>Operation modes</b>	free running mode, overlapped readout
<b>Signal processing</b>	
Exposure control	Internal, 4 msec
Gain control	factor 1 = 0 dB
Offset (black level)	0
<b>Image acquisition</b>	
Camera image format mode	Full frame Mono8, 16 tap readout
Pixel frequency	48 MHz
Partial scan function	not active
Acquisition frame rate	Off
Timer	Off
Transmission delay	0 ticks
Test image selector	Off
Defect pixel correction	On
FPN correction	Off
<b>Electrical interface</b>	
Digital input	1 / 2 / 3: Line 0 / Line 1 / Line 2: invert = false
Digital output	1 / 2 / 3: Line 3 / Line 4 / Line 5: Line source=Off, invert = false, digital output set to low status (high impedance)

## 3. Timing Operation Modes

Trigger Mode: start up time

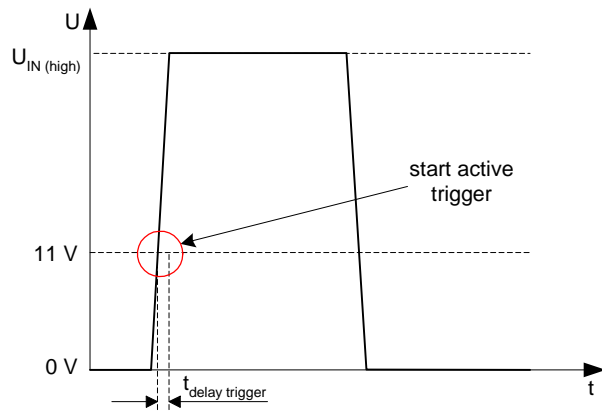

Trigger Mode: trigger mode 0, overlapped trigger

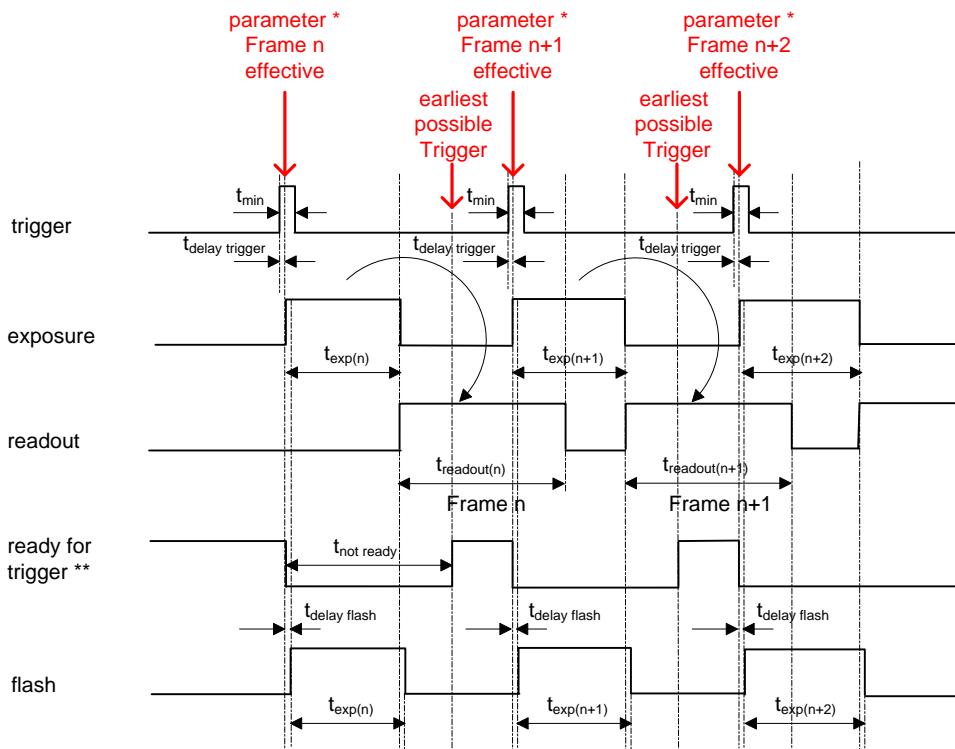

$$t_{exp} < t_{readout}: t_{earliest\ possible\ trigger\ (n+1)} = t_{readout(n)} - t_{exp(n+1)}$$

$$t_{exp} > t_{readout}: t_{earliest\ possible\ trigger\ (n+1)} = t_{exp(n)}$$

$$t_{exp} < t_{readout}: t_{not\ ready\ (n+1)} = t_{exp(n)} + t_{readout(n)} - t_{exp(n+1)}$$

$$t_{exp} > t_{readout}: t_{not\ ready\ (n+1)} = t_{exp(n)}$$

\* image parameter: exposure  
offset  
gain  
readout mode  
LUT  
flip image

\*\* signal will be notified as event "TriggerReady"

Trigger Mode: trigger mode 0, overlapped trigger , when  $t_{exp(n+2)} > t_{exp(n+1)}$

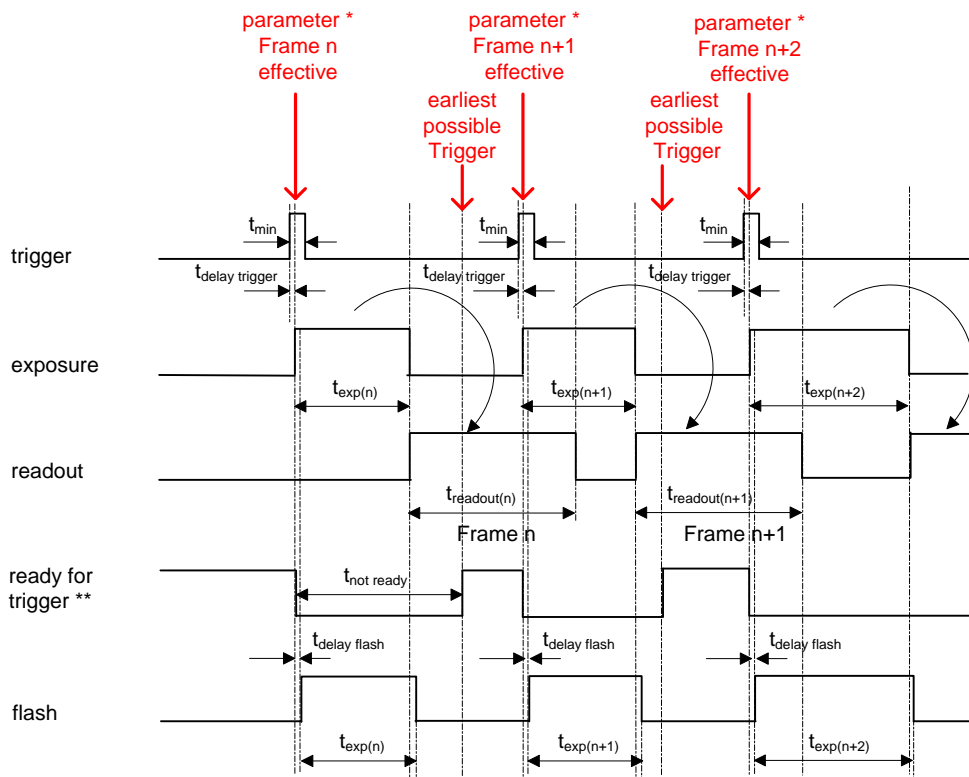

$$t_{exp} < t_{readout}: t_{earliest\ possible\ trigger\ (n+1)} = t_{readout(n)} - t_{exp(n+1)}$$

$$t_{exp} > t_{readout}: t_{earliest\ possible\ trigger\ (n+1)} = t_{exp(n)}$$

$$t_{exp} < t_{readout}: t_{not\ ready\ (n+1)} = t_{exp(n)} + t_{readout(n)} - t_{exp(n+1)}$$

$$t_{exp} > t_{readout}: t_{not\ ready\ (n+1)} = t_{exp(n)}$$

\* image parameter: exposure  
offset  
gain  
readout mode  
LUT  
flip image

\*\* signal will be notified as event "TriggerReady"

Trigger Mode: trigger mode 0, overlapped trigger , when  $t_{exp(n+2)} < t_{exp(n+1)}$

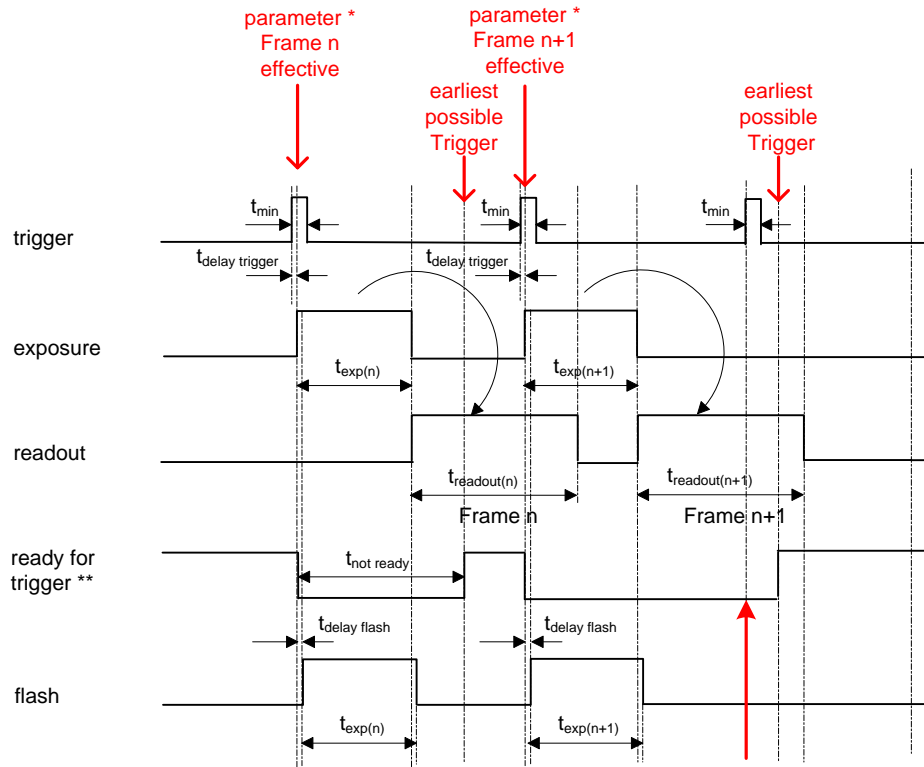

$$t_{exp} < t_{readout}: t_{earliest\ possible\ trigger\ (n+1)} = t_{readout(n)} - t_{exp(n+1)}$$

$$t_{exp} > t_{readout}: t_{earliest\ possible\ trigger\ (n+1)} = t_{exp(n)}$$

$$t_{exp} < t_{readout}: t_{not\ ready\ (n+1)} = t_{exp(n)} + t_{readout(n)} - t_{exp(n+1)}$$

$$t_{exp} > t_{readout}: t_{not\ ready\ (n+1)} = t_{exp(n)}$$

- \* image parameter:
- exposure
  - offset
  - gain
  - readout mode
  - LUT
  - flip image

\*\* signal will be notified as event "TriggerReady"



Free Running Mode: overlapped operation

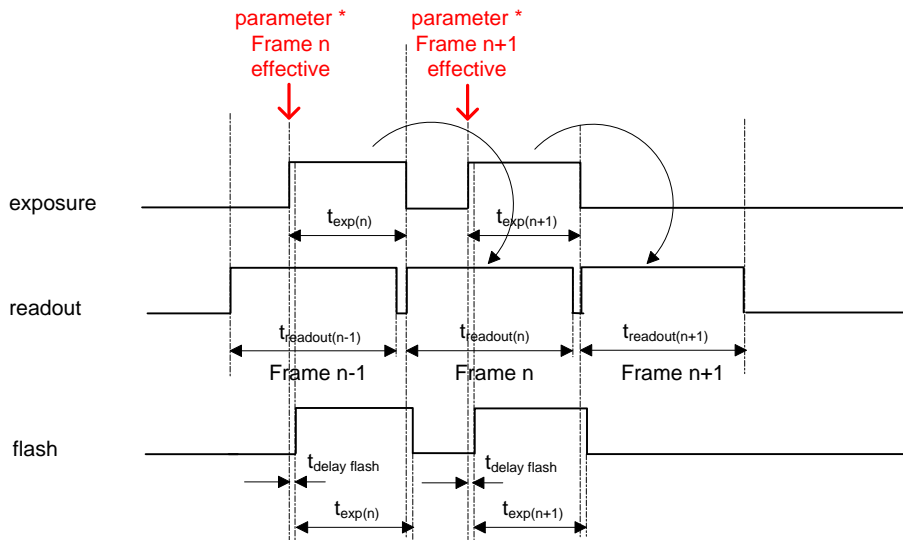

\* image parameter:  
 exposure  
 offset  
 gain  
 readout mode  
 LUT  
 flip image

#### 4. Region of Interest (ROI) Examples

The following table lists achievable frame rates in burst mode for a short time using the integrated image buffer of 256 MB and continuously over the Dual GigE interface.

Format	Resolution	max. fps burst mode (buffered)	max. fps continuously (Single GigE) (*1)	max. fps continuously (Dual GigE) (*1)
	2048 x 1080	338	53	106
HDTV	1920 x 1080	338	56	113
	1280 x 720	504	127	253
XGA	1024 x 768	473	149	297
DVD	736 x 576	627	277	546
VGA	640 x 480	748	382	747
CIF	352 x 288	1.221	1144	1217
QCIF	176 x 144	2.319	2300	2300
Line Scan	2048 x 1024	357	56	112
	2048 x 512	703	112	223
	2048 x 256	1.363	224	443
	2048 x 128	2.576	447	877
	2048 x 64	4.637	888	1736
	2048 x 32	7.712	1754	3231
	2048 x 16	11.560	3438	6023
	2048 x 8	15.407	6540	-
	2048 x 4	18.436	-	-
	2048 x 2	20.349	-	-
	2048 x 1	21.653	-	-

(\*1) For small ROI settings many packets are transmitted and have to be processed by the PC. The actual frame rate depends on the PC performance. If the PC is not fast enough to process the incoming packets an overload situation may occur.

5. Housing

5.1 C-Mount

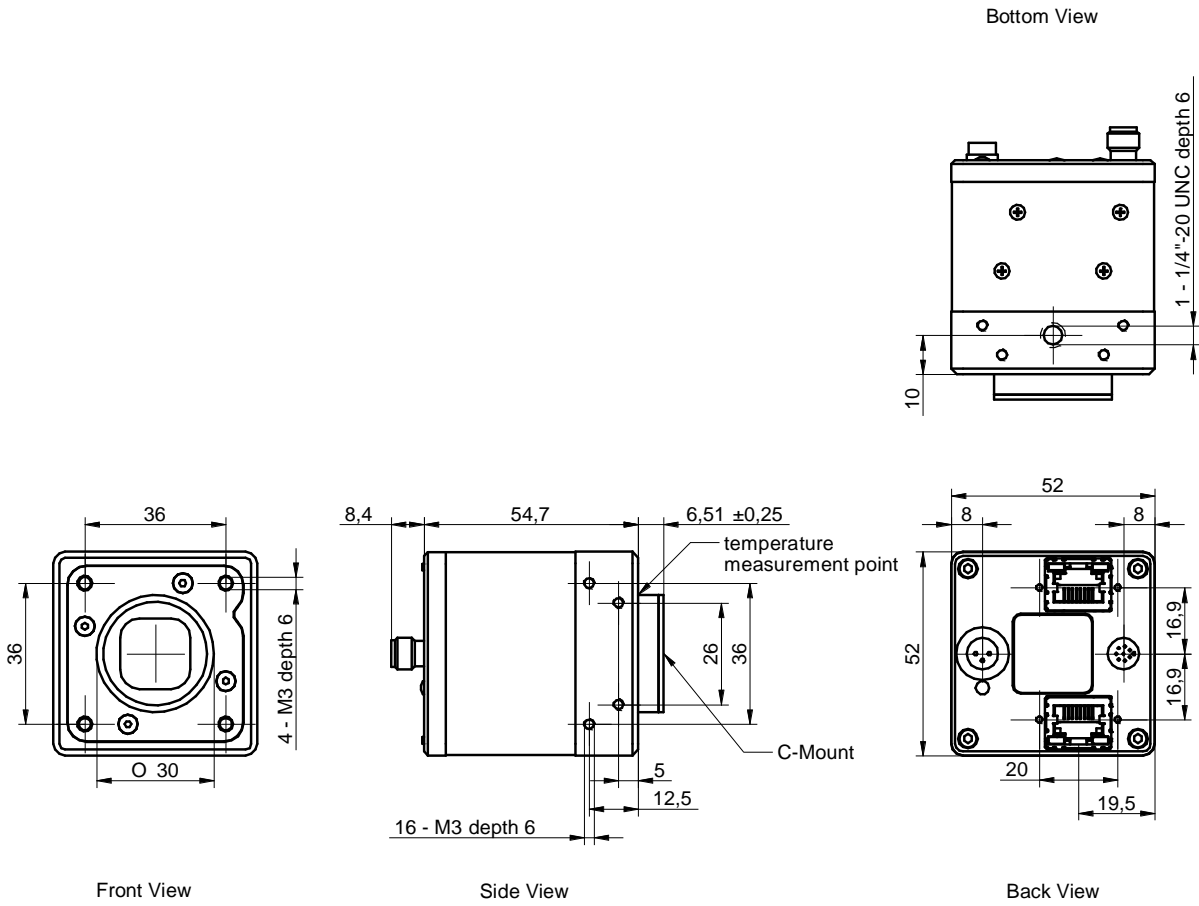

Technical specifications subject to change

5.2 F-Mount

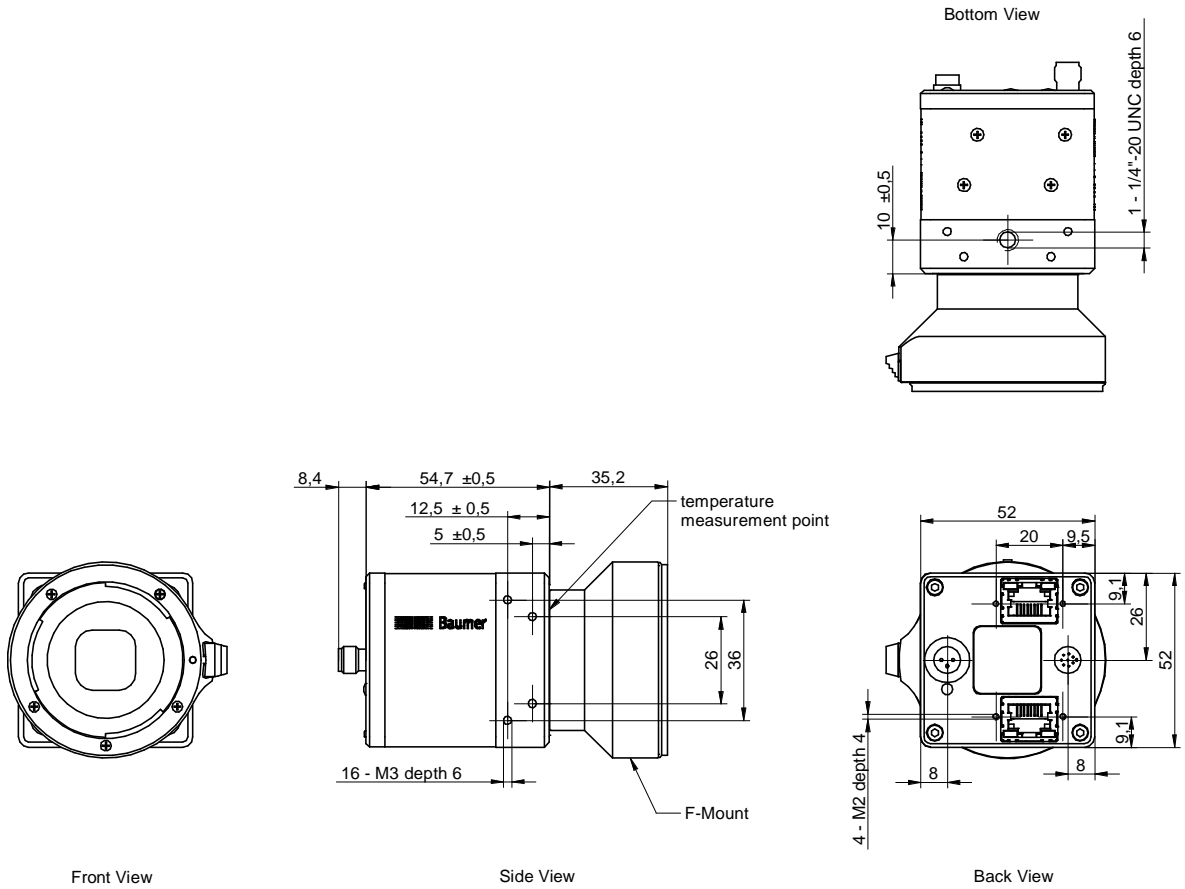

Technical specifications subject to change

6. Connectors / Electrical Interfaces

6.1 Pin assignment:

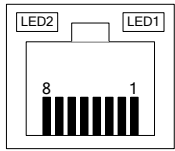
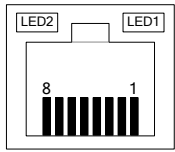
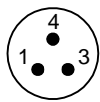
<b>Data / Control</b> <b>1000 Base-T (Port 1)</b>	Type: RJ45 8P8C mod jack
	1: MX1+ 2: MX1- 3: MX2+ 4: MX3+ 5: MX3- 6: MX2- 7: MX4+ 8: MX4-
<b>Data / Control</b> <b>1000 Base-T (Port 2)</b>	Type: RJ45 8P8C mod jack
	1: MX1+ 2: MX1- 3: MX2+ 4: MX3+ 5: MX3- 6: MX2- 7: MX4+ 8: MX4-
<b>Power</b>	Type: Lumberg RSMESD / 3 pin
	1: Power VCC+ 3: GND 4: not used
	Power cable wires color: 1 = brown 3 = blue 4 = black

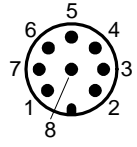
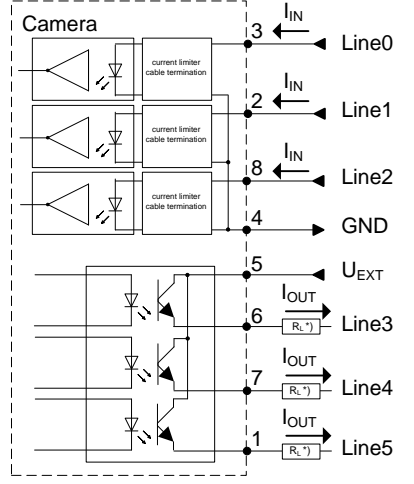
<b>Input / Output</b>	Type: Lumberg RSMESD 8pin.
	
	*) resistor must be used, drawing shown above example for using high active signal
	I/O cable wires color *): 1 = white 2 = brown 3 = green 4 = yellow 5 = grey 6 = pink 7 = blue 8 = red

\*) shielded trigger / flash cable should be used and ordered separately

6.2 Flash sync sample  $U_{EXT} = 24\text{ VDC}$  high active:

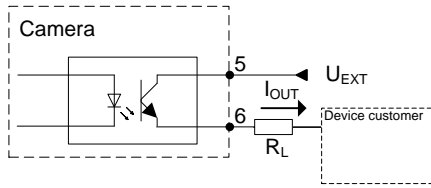

Timing example:  
 measurement condition  $U_{EXT} = 24\text{ VDC} / I_{OUT} = 16\text{ mA}$   
 $R_L = 1.5\text{ kOhm}$

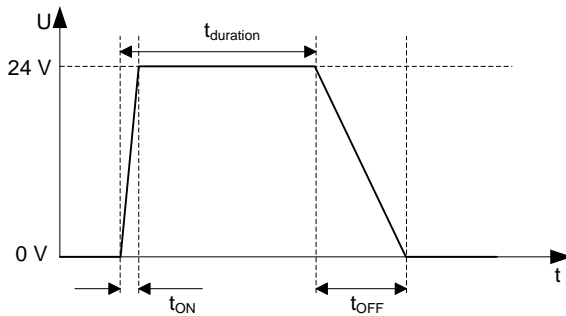

$t_{ON}$  time = typ.  $2\ \mu\text{sec}$   
 $t_{OFF}$  time = typ.  $40\ \mu\text{sec}$

6.3 Flash sync sample  $U_{EXT} = 24\text{ VDC}$  low active:

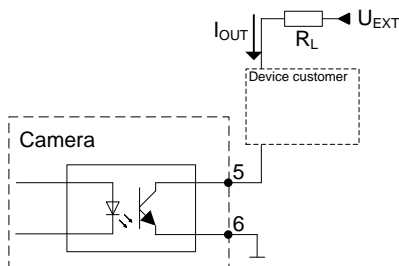

Timing example:  
 measurement condition  $U_{EXT} = 24\text{ VDC} / I_{OUT} = 16\text{ mA}$   
 $R_L = 1.5\text{ kOhm}$

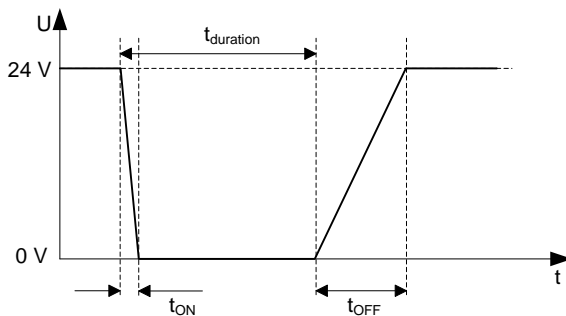

$t_{ON}$  time = typ.  $2\ \mu\text{sec}$   
 $t_{OFF}$  time = typ.  $40\ \mu\text{sec}$

End of Document

Technical specifications subject to change

## History of TDS Baumer HXG20c

Date	Version	Name	Pages/ Chapter	Change
13.12.2011	0.1	mibe	all	Initial version based on HXC20c, HXG20
09.01.2012	0.2	mibe	4	Operating temperature
20.01.2012	0.3	mibe	13	New F-Mount drawing without Nikon dust protection
23.02.2012	1.0	mibe	1	Removed preliminary note
09.07.2012	1.0	mibe	3	IR Cut Filter Hoya -> Balzer
01.03.2013	1.0	mibe	1, 3	Changes for Firmware Revision 2 Support of v3 Sensors (not mentioned) Modified DSNU/PRNU (FPN), added HDR/Multi ROI Removed temperature measurement New IR Cut Filter Balzer -> Micros
30.5.2013	1.0	mibe	2	Burst mode frame rate with 10 bit corrected (=8bit)
23.07.2013	1.1	zira	1	according SFNC: Naming changed from <i>User</i> to <i>UserOutput</i> , CounterTriggerSource to CounterEventSource, SoftwareTrigger to Software, ActCmdTrigger to Action1, added CounterActive ReadoutTime unit in $\mu$ s
06.8.2013	1.1	mibe	1	Minimum exposure = 20 $\mu$ s
12.08.2013	1.0	mibe	1	Change name <i>_R2_</i> , corrected read out time Footer <a href="http://www.baumeroptronic.com">www.baumeroptronic.com</a> -> <a href="http://www.baumer.com">www.baumer.com</a>