

**Digital Monochrome (b/w)
Progressive Scan Camera
With Enhanced NIR Sensitivity**

System: **CameraLink® Full**

Baumer HXC20NIR/HXC20NIR-F

Art. No: **11047485 (C-Mount)
11047895 (F-Mount)**

Revision 2.0

- CameraLink® Full progressive scan CMOS camera
- 2048 x 1088 pixel with up to 337 full frames per second
- Excellent image quality
- Global shutter architecture for minimized motion blur
- Low noise due to correlated double sampling (CDS)
- Binning, subsampling and true partial scan function (ROI) for increased frame rates
- High Dynamic Range (HDR) image acquisition
- External synchronization via industrial compliant process interface (trigger / flash)
- Integrated supplementary function for flexible integration
- Sequence function up to $2^{31}-1$ frames per sequence
- Integrated 256 MByte RAM for temporarily image data buffering
- Compact and lightweight aluminum housing
- Two standard 26 pin Mini-CameraLink® connectors
- Support for CameraLink® Base, Medium, Full and 10 tap configurations
- Camera parameter programmable via configuration tool for Windows
- Baumer-GAPI: Flexible, generic software interface for Windows



1. Overview

Model Name	HXC20NIR / HXC20NIR-F
Sensor	2/3" progressive scan CMOS
Vendor and Model	CMOSIS CMV-2000 v2
Shutter / readout mode	global shutter / progressive scan readout
Number of pixel	2048 x 1088
Scan area	11.26 mm x 5.98 mm
Pixel size	5.5 µm x 5.5 µm
Color filter	-
Operation modes	
Trigger mode	yes, sequential or overlapped operation
Free running mode	yes, sequential or overlapped operation
Sensor readout channels	16 / 8 / 4 / 2 channel readout
Signal processing	real-time software programmable
Pixel clock	8/10 bit pixel format: 24/40/48 MHz 12 bit pixel format: 20/40 MHz
A/D converter	10 or 12 bit depending on pixel format
Internal exposure control (t_{exp})	total: 20 µsec .. 1 sec step 1 µsec (exposure time of up to 60 sec can be set via direct register configuration)
Trigger pulse width exposure control	Yes, via all trigger lines, Valid range: 20 µsec .. 60 sec
Gain control	0 .. 12 dB
Offset (black level)	0 .. 255 LSB
Image data buffer	Max. 110 full resolution images

Technical specifications subject to change

Image acquisition						
Camera image format modes	Format (pixel)	Gen<math>\langle\rangle\rangleCam standard	Pixel format	Pixel clock MHz	Frames per sec. (*1)	t_{readout}
Full frame	2048 x 1088	yes	Mono8 (*3)	48	337	2,97 ms
			Mono10	48	142 (*2)	2,97 ms
			Mono12	40	70	14,14 ms
Binning 2x1	1024 x 1088	yes	Mono8 (*3)	48	337	2,97 ms
			Mono10	48	281 (*2)	2,97 ms
			Mono12	40	70	14,14 ms
Subsampling 2x2	1024 x 544	Vendor specific	Mono8 (*3)	48	664	1,51 ms
			Mono10	48	560	1,51 ms
			Mono12	40	140	7,12 ms
Standard features						
Image size controls						
Binning horizontal	yes, 2 pixel					
Binning vertical	-					
Pixel format	Mono8, Mono10, Mono12					
Test image selector	yes, in all modes Off, GreyHorizontalRamp, GreyVerticalRamp					
Partial scan (ROI)	yes, format freely programmable in all modes, Step size horizontal: 32 pixels Step size vertical: 1 pixel					
Multi partial scan (Multi ROI)	yes, up to 8 horizontal and vertical regions					
Analog controls						
Gain	-					
Black Level (Off set)	yes					
Gamma	yes, via LUT					
Brightness correction (custom)	yes, in all binning modes					
Digital controls						
Digital gain	yes, factors 1.0 to 4.0 (*4)					
Acquisition and Trigger						
Acquisition mode	Continuous					
Acquisition frame rate	yes, ON / OFF (only in freerunning mode) 0 .. 21739 Hz, step: 0.01 Hz					
Trigger source	HardwareTrigger (Line0, Line1, Line2), SoftwareTrigger, FrameGrabber (Line3/CC1, Line4/CC2, Line5/CC3, Line6/CC4) or Off					
Trigger delay	0 .. 2 sec, 512 trigger can be tracked, step: 1 μ sec					
Sequencer	Up to $2^{31}-1$ frames per sequence / one exposure time, one gain value and outputs for each parameter set max. set of sequences: Up to $2^{31}-1$ frames x 128 parameter sets					

Digital I/O	
Lines	Input: Line0, Line1, Line2 Output: Line7, Line 8, Line 9
Line source (outputs only)	Line7, Line8, Line9: Off, ExposureActive, Timer1Active, FrameActive, TransferActive, TriggerReady, TriggerOverLapped, TriggerSkipped, Line0, Line1, Line2, Line3/CC1, Line4/CC2, Line5/CC3, Line6/CC4, User0, User1, User2, SequencerOutput0, SequencerOutput1, SequencerOutput2
Line debouncer	yes, low and high signal separately selectable 0 .. 5 msec step: 1µsec
Line inverter	yes, Line0 .. Line9, on or off
Counters and Timers	
Framecounter	-
Timer	yes, TimerSelector: Timer1 TimerTriggerSource: Off, Input: Line0/Line1/Line2, SoftwareTrigger ExposureStart, ExposureEnd, FrameStart, FrameEnd, TriggerSkipped TimerDelay: 0 µsec .. 2 sec, step: 1 µsec TimerDuration: 10 µsec .. 2 sec, step: 1 µsec
LUT Controls	
LUT selector	1 LUT: Luminance (12 bit), ON / OFF
Image Correction	
Defect pixel correction	yes, ON / OFF
Defect pixel list	yes, additional pixels can be added during the lifetime of the camera
DSNU / PRNU (FPN) correction	yes, ON / OFF, based on offset / factor per column, data set calculated with factory settings during production and stored in camera
UserSets	
User set selector	Default (factory settings / read only) UserSet1, UserSet2, UserSet3 (read and write)
UserSetDefaultSelector	yes, define the start up "UserSet"
Advanced features	
Image Flip	Horizontal, vertical or both
Time stamp function	-
High Dynamic Range (HDR)	Yes, piecewise linear response, up to 90 dB
Data quality	at 20 °C, gain = 1, exposure time = 4 msec, full frame mode
Readout noise	$\sigma < 0.3$ LSB (8 bit) typical
Dynamic range	typical 60 dB
Optical interface	C-Mount on request: F-Mount
Optical filter	dust protection on request: no filter
Process interface functions	
Async. Trigger	yes, trigger mode operation, "Off", "software trigger", "hardware trigger", "framegrabber trigger" separately selectable
Exposure Active (External flash sync)	yes, delay_value ($t_{\text{delay flash}}$) ≤ 4 µsec, duration_value (t_{duration}): mode = $t_{\text{exp}} + 30$ µsec
User Output	yes, ON / OFF, User0, User1, User2
Timer	yes, Timer1
Software reset	Yes
Asynchronous reset	-
Image info header	-
Temperature measurement	yes, internal sensor temperature range: 0 °C .. +127 °C

Electrical interface			
Data / control	Dual 26 pin Mini-CameraLink connector		
Power	Mono8, CameraLink base, dual tap, 40 MHz VCC: 9,6 VDC .. 30 VDC, I: 550 mA .. 190 mA		
	Mono8, CameraLink full, 10 tap, 48 MHz VCC: 9,6 VDC .. 30 VDC, I: 620 mA .. 200 mA		
Power consumption	approx. 5,5 Watt (with camera factory settings)		
Digital input	1 / 2 / 3:	Line 0 / Line 1 / Line 2: trigger signal, opto decoupled $U_{IN(low)} = 0 \dots 4.5 \text{ VDC}$, $U_{IN(high)} = 11 \dots 30 \text{ VDC}$ $I_{IN} = \text{max. } 10 \text{ mA}$ rising edge (invert = false) (*5) min. impulse length (t_{min}): 2 μsec trigger delay out of $t_{readout}$ ($t_{delay \text{ trigger}}$): 4 μsec max. trigger delay during $t_{readout}$ ($t_{delay \text{ trigger}}$): 30 μsec	
Digital output	1 / 2 / 3:	Line 7 / Line 8 / Line 9: opto decoupled $U_{EXT} = 5 \dots 30 \text{ VDC} / 24 \text{ VDC typical}$, $I_{OUT} = \text{max. } 100 \text{ mA}$ high active (invert = false) (***)	
LED	1:	green:	Power on
		yellow:	Readout active
	2:	green:	TX
		red:	Configuration command processing
Environmental			
Storage temperature	-10 °C .. +70 °C		
Operating temperature	+5 °C .. +60 °C		
Housing operating temperature	between +30 °C .. +60 °C, note the max. housing and internal temperature		
	max. +65 °C (*6)		
	(measurement point, see item 4)		
Humidity	10 % .. 90 % non condensing		
Conformity	CE, FCC Part 15 class B, RoHS compliant		
Housing		Aluminum	
Dimensions	52 x 52 x 38 mm ³ (C-Mount)		
	52 x 52 x 37 mm ³ (F-Mount)		
Weight	185 g (C-Mount)		
	276 g (F-Mount)		
CameraLink interface		Base, Medium, Full or 10-tap	
Clock	80 MHz		
Data Formats	Mono8	Base configuration	1, 2 or 3 taps
		Medium configuration	4 taps
		Full configuration	8 taps
		10-tap configuration	10 taps
	Mono10	Base configuration	1 or 2 taps
		Medium configuration	3 or 4 taps
	Mono12	Base configuration	1 or 2 taps
		Medium configuration	3 or 4 taps
Software		Baumer-GAPI SDK for Windows XP (32 bit) / Windows Vista (32 bit / 64bit), Supported FrameGrabber: Silicon Software microEnable IV Tool for camera configuration via CameraLink serial interface	

- (*1) Maximum frame rate in free running mode, effective frame rate depending on camera image format mode settings and set exposure time ($t_{exp} < t_{readout}$). This assumes 16 tap readout at maximum pixel frequency.
- (*2) Limited by the speed of the CameraLink interface. In 10 and 12 bit modes only a medium configuration is possible.
- (*3) Default pixel format
- (*4) Digital gain is applied on the raw data obtained from the sensor. In 10 and 12 bit modes, this is just a bit shift cutting away the MSBs!
- (*5) can be inverted via software
- (*6) housing temperature is limited by CMOS sensor specification

In warm environments take care of adequate dissipation of heat. It is recommended to operate the cameras in mounted condition with a good heat conductor (e.g. aluminum) or with sufficient air flow.

2. Camera Factory Settings after Camera Start-up

Camera factory settings after camera start-up or reboot	
Operation modes	free running mode, overlapped readout
Signal processing	
Exposure control	Internal, 4 msec
Gain control	factor 1 = 0 dB
Offset (black level)	0
Image acquisition	
Camera image format mode	Full frame Mono8, 16 tap readout
Pixel frequency	48 MHz
Partial scan function	not active
Acquisition frame rate	Off
Timer	Off
Test image selector	Off
Defect pixel correction	On
FPN correction	Off
CameraLink interface	
Configuration	Mono8, Dual tap CameraLink Base
Clock	80 MHz
Electrical interface	
Exposure Active (External flash sync)	disabled, digital output set to low status (high impedance) invert = false
Async. Trigger	disabled invert = false trigger source = Line0

3. Timing Operation Modes

Trigger Mode: start up time

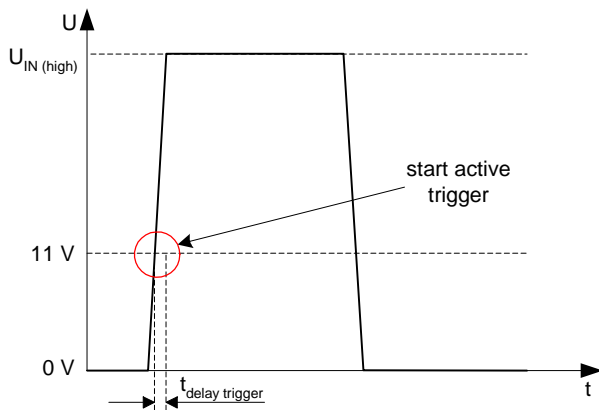

Trigger Mode: trigger mode 0, overlapped trigger

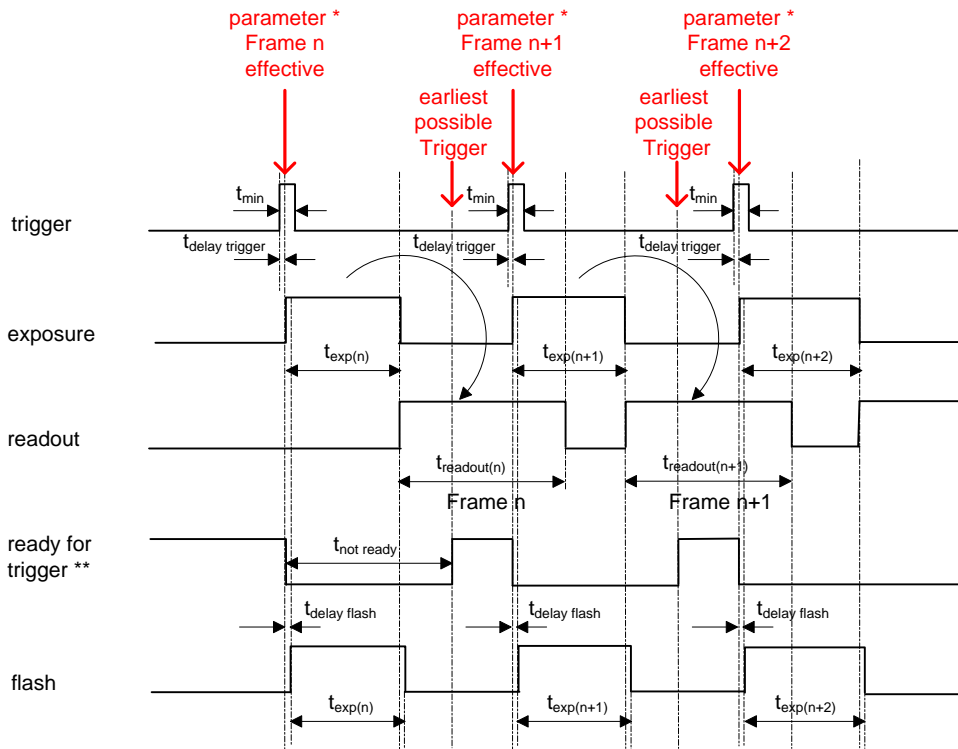

$$t_{exp} < t_{readout}: t_{earliest\ possible\ trigger\ (n+1)} = t_{readout(n)} - t_{exp(n+1)}$$

$$t_{exp} > t_{readout}: t_{earliest\ possible\ trigger\ (n+1)} = t_{exp(n)}$$

$$t_{exp} < t_{readout}: t_{not\ ready\ (n+1)} = t_{exp(n)} + t_{readout(n)} - t_{exp(n+1)}$$

$$t_{exp} > t_{readout}: t_{not\ ready\ (n+1)} = t_{exp(n)}$$

* image parameter: exposure
offset
gain
readout mode
LUT
flip image

** signal will be notified as event "TriggerReady"

Trigger Mode: trigger mode 0, overlapped trigger , when $t_{exp(n+2)} > t_{exp(n+1)}$

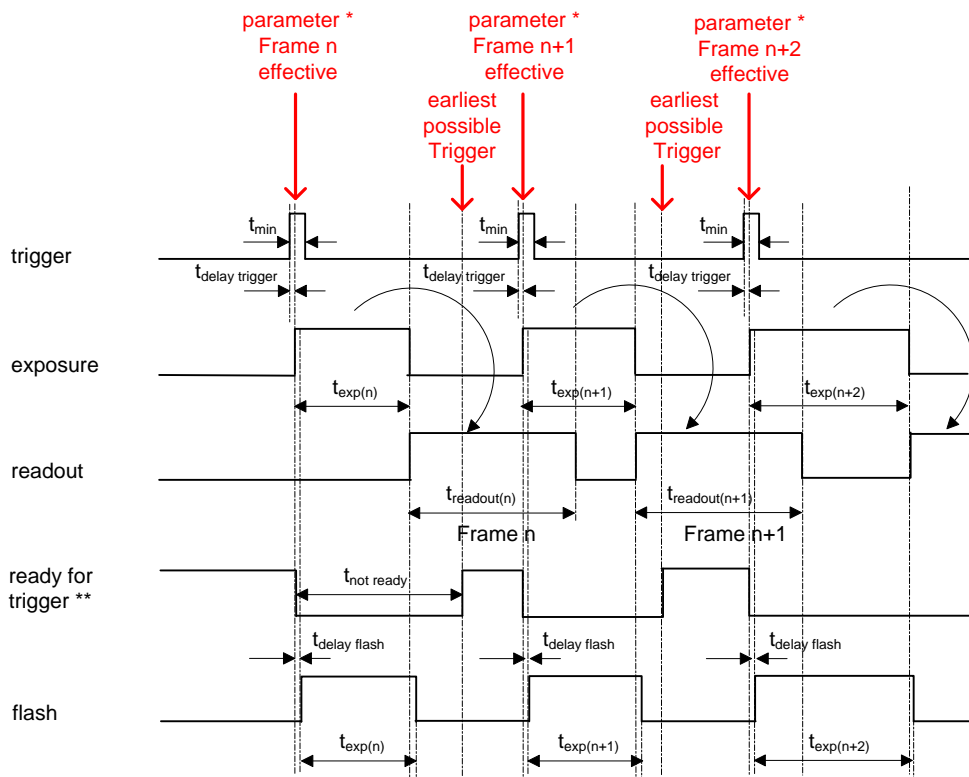

$$t_{exp} < t_{readout}: t_{earliest\ possible\ trigger\ (n+1)} = t_{readout(n)} - t_{exp(n+1)}$$

$$t_{exp} > t_{readout}: t_{earliest\ possible\ trigger\ (n+1)} = t_{exp(n)}$$

$$t_{exp} < t_{readout}: t_{not\ ready\ (n+1)} = t_{exp(n)} + t_{readout(n)} - t_{exp(n+1)}$$

$$t_{exp} > t_{readout}: t_{not\ ready\ (n+1)} = t_{exp(n)}$$

* image parameter: exposure
offset
gain
readout mode
LUT
flip image

** signal will be notified as event "TriggerReady"

Trigger Mode: trigger mode 0, overlapped trigger , when $t_{exp(n+2)} < t_{exp(n+1)}$

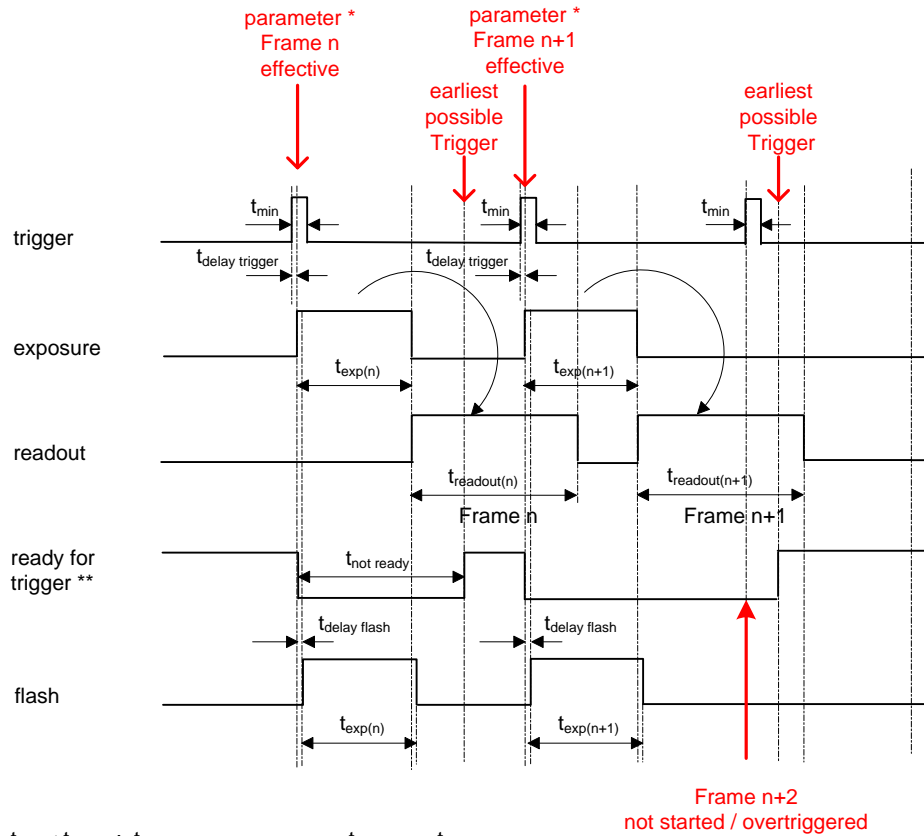

$$t_{exp} < t_{readout}: t_{earliest\ possible\ trigger\ (n+1)} = t_{readout(n)} - t_{exp(n+1)}$$

$$t_{exp} > t_{readout}: t_{earliest\ possible\ trigger\ (n+1)} = t_{exp(n)}$$

$$t_{exp} < t_{readout}: t_{not\ ready\ (n+1)} = t_{exp(n)} + t_{readout(n)} - t_{exp(n+1)}$$

$$t_{exp} > t_{readout}: t_{not\ ready\ (n+1)} = t_{exp(n)}$$

- * image parameter:
- exposure
 - offset
 - gain
 - readout mode
 - LUT
 - flip image

** signal will be notified as event "TriggerReady"

Free Running Mode: overlapped operation

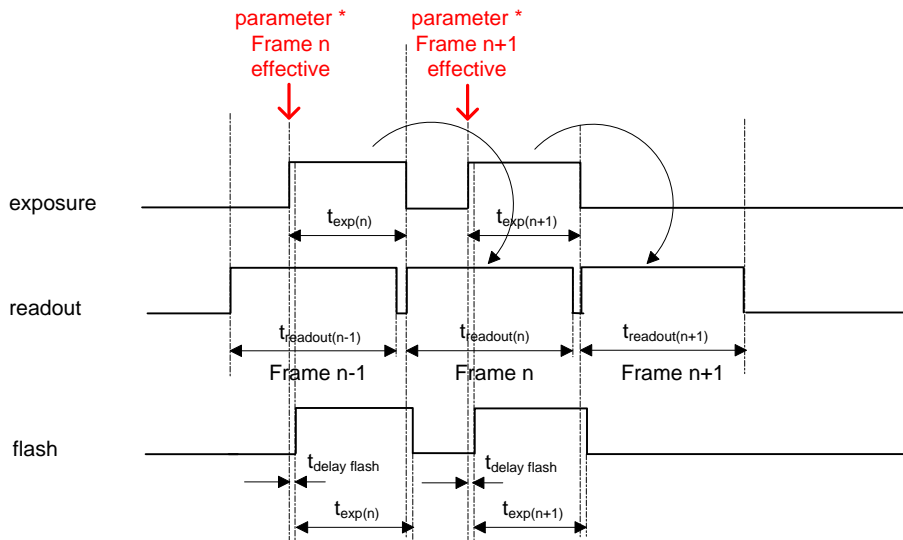

* image parameter: exposure
offset
gain
readout mode
LUT
flip image

4. Region of Interest (ROI) Examples

The following table lists achievable frame rates in 10 tap / 8 bit mode.

Format	Resolution	max. fps
2k	2048 x 1080	338
HDTV	1920 x 1080	338
	1280 x 720	504
XGA	1024 x 768	473
DVD	720 x 576	627
VGA	640 x 480	748
CIF	352 x 288	1.221
QCIF	176 x 144	2.319
Line Scan	2048 x 1024	357
	2048 x 512	703
	2048 x 256	1.363
	2048 x 128	2.576
	2048 x 64	4.637
	2048 x 32	7.712
	2048 x 16	11.560
	2048 x 8	15.407
	2048 x 4	18.436
	2048 x 2	20.349
	2048 x 1	21.653

5. Spectral Response (QE)

The higher NIR sensitivity is achieved via a thicker epi substrate of the sensor.

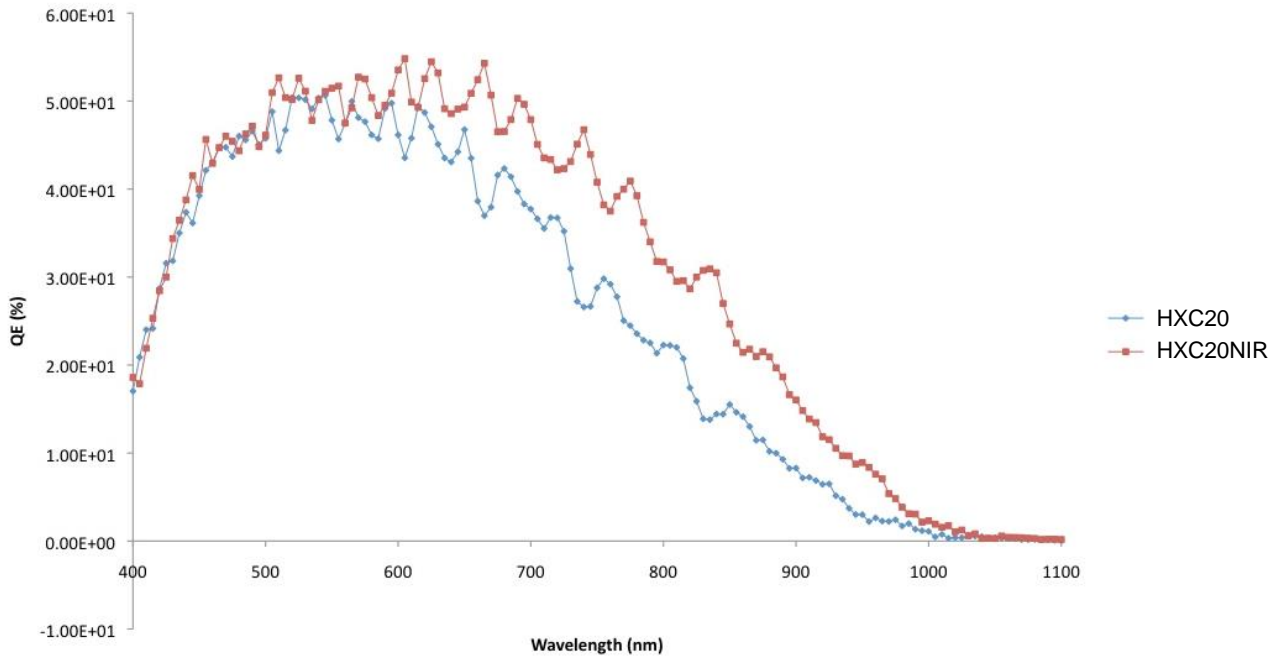

6. Housing

6.1 C-Mount

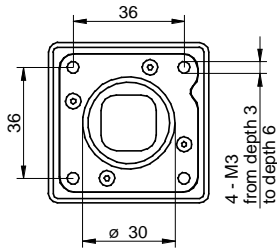

Front View

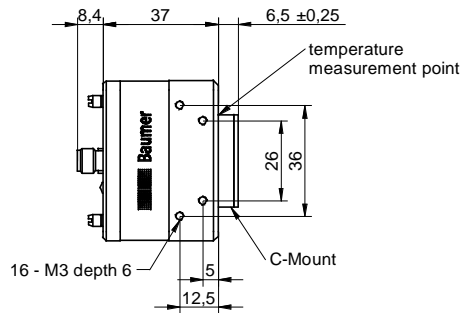

Side View

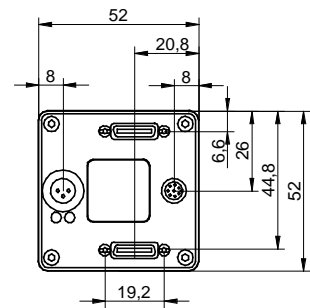
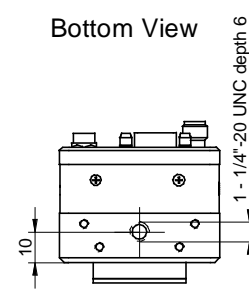

Back View

6.2 F-Mount

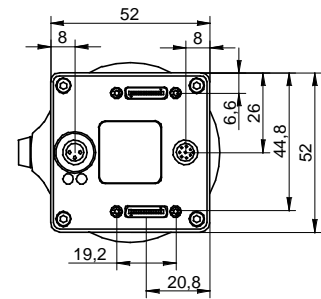
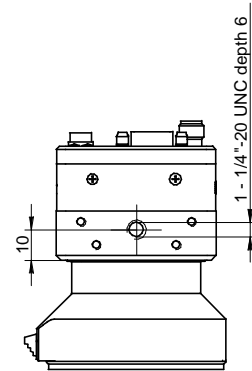
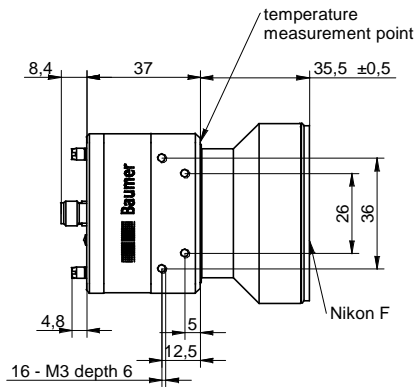
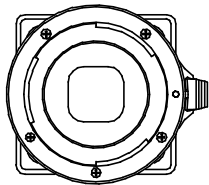

7. Connectors / Electrical Interfaces
7.1 Pin assignment:

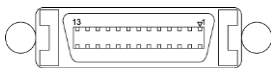
Data / Control CameraLink Base	Type: 3M SDR26 MiniCL
	1: GND 2: X0- 3: X1- 4: X2- 5: XCLK- 6: X3- 7: SERTC+ 8: SERTFG- 9: CC1- 10: CC2+ 11: CC3- 12: CC4+ 13: GND 14: GND 15: X0+ 16: X1+ 17: X2+ 18: XCLK+ 19: X3+ 20: SERTC- 21: SERTFG+ 22: CC1+ 23: CC2- 24: CC3+ 25: CC4- 26: GND

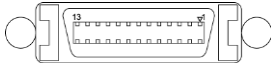
Data CameraLink Full	Type: 3M SDR26 MiniCL
	1: GND 2: Y0- 3: Y1- 4: Y2- 5: YCLK- 6: Y3- 7: 100 Ω Term. 8: Z0- 9: Z1- 10: Z2- 11: ZCLK- 12: Z3- 13: GND 14: GND 15: Y0+ 16: Y1+ 17: Y2+ 18: YCLK+ 19: Y3+ 20: 100 Ω Term 21: Z0+ 22: Z1+ 23: Z2+ 24: ZCLK+ 25: Z3+ 26: GND

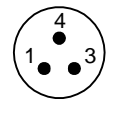
Power	Type: Lumberg RSMESD / 3 pin
	1: Power VCC+ 3: GND 4: not used
	Power cable wires color: 1 = brown 3 = blue 4 = black

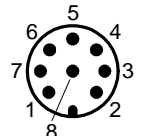
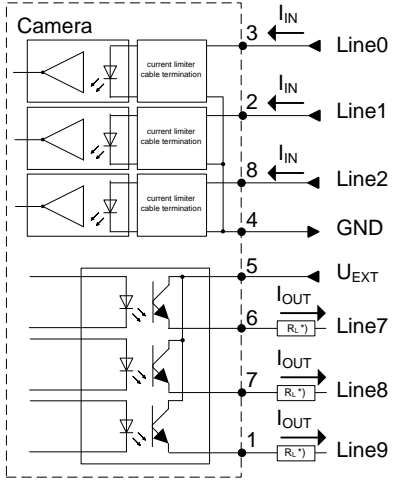
Input / Output	Type: Lumberg RSMESD 8pin.
	
	*) resistor must be used, drawing shown above example for using high active signal
	I/O cable wires color *): 1 = white 2 = brown 3 = green 4 = yellow 5 = grey 6 = pink 7 = blue 8 = red

*) shielded trigger / flash cable should be used and ordered separately

Technical specifications subject to change

7.2 Flash sync sample $U_{EXT} = 24\text{ VDC}$ high active:

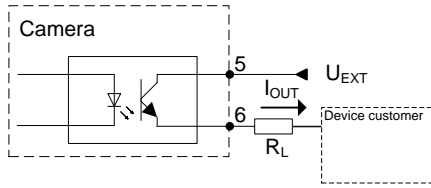

Timing example:
 measurement condition $U_{EXT} = 24\text{ VDC} / I_{OUT} = 16\text{ mA}$
 $R_L = 1.5\text{ kOhm}$

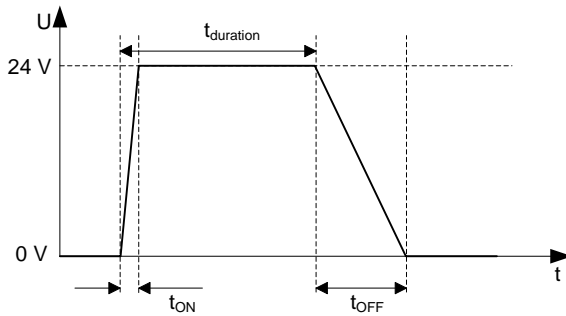

t_{ON} time = typ. $2\ \mu\text{sec}$
 t_{OFF} time = typ. $40\ \mu\text{sec}$

7.3 Flash sync sample $U_{EXT} = 24\text{ VDC}$ low active:

Note: This setup can only be used for a single output because U_{EXT} is connected for all three outputs.

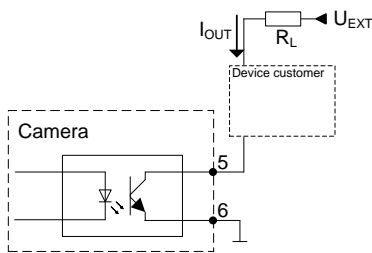

Timing example:
 measurement condition $U_{EXT} = 24\text{ VDC} / I_{OUT} = 16\text{ mA}$
 $R_L = 1.5\text{ kOhm}$

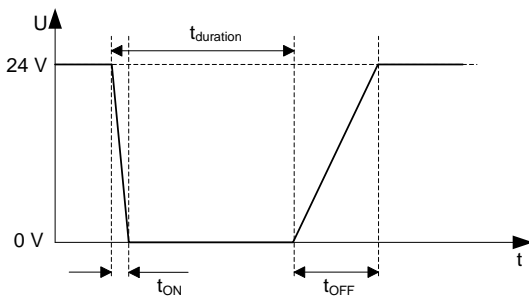

t_{ON} time = typ. $2\ \mu\text{sec}$
 t_{OFF} time = typ. $40\ \mu\text{sec}$

8. Application Notes

The following application notes regarding the camera are available from Baumer:

- Sensor frame rate calculation and interface speed (BTI_HXC20_HXC40_Frame_Rate_Calculation)
- Pixel defect and sensor cover glass specification (BTI_HXC20_HXC40_Pixel_Glass_Specification)

The following additional information regarding the image sensor is currently known and can be obtained from the sensor manufacturer's website (www.cmosis.com):

- CMV2000 and CMV4000 Application note AN2 (black sun artefact, horizontal line artefact)