

Mechanical Integration

The light is equipped with M4 threaded holes at each end. It can be used to fix the lighting to the specified position. In addition M2.5 threaded holes are provided at the two long sides to mount the foil and filter holder set.

Spot: The spot is equipped with 1x M8 and 3x M4 threaded holes at one side to fix the lighting to a specified position.

To ensure a long operational lifetime of the light additional heat transfer measures at the mounting positions are highly recommended.

Example: Model High Power WBL-0420

More 2D and 3D drawings can be found online:
www.mbj-imaging.com

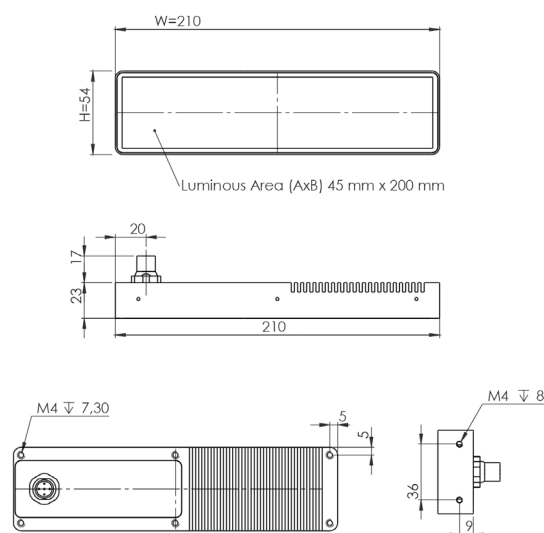

Specification	High Power Series
Operating temperature	10°C to 30°C / 45°C ¹⁾
Certifications	CE, RoHS
Degree of protection	IP54 or IP67 ²⁾
Humidity	30% to 70%

1) Max. of 30°C is recommended for steady light operation w/o additional heat transfer measurements, for max. 45°C a thermal connection is mandatory. Max. of 45°C is also permissible for flash light operation with a max. 10% duty cycle.

2) MBJ LED lights are protected against the ingress of solids and water in accordance with the selected protection class and applicable standards. Permanent protection against liquids containing solvents, such as cleaning agents, machine emulsions or other lubricants, cannot be guaranteed. IP is only valid with a connected cable (MBJ cable recommended). High Power Spotlights are not available as IP67.

Safety Notes

Before working with this unit, read the warning and application instructions carefully and completely before operating the device.



1. The device is designed for indoor use only.
2. **Light** – Due to the risk of flash burn of the eyes it is not recommended to look directly into the light source. The lighting must be switched off before installation and/or maintenance. The device must not be used when a failure may cause a personal injury.
3. **Heat** – In case of insufficient heat dissipation or when running the light in flash mode with a too high duty cycle, the surface temperature may exceed 60 °C. Keep off flammable materials at any time.
4. **Electricity** – The housing is electrically isolated from the ground of the power supply. Exceeding the permissible input voltage U_{in} or $U_{LED(+)}$ can lead to the destruction of the device or to a significant shortening of the lifetime of the LEDs in the device.
5. **Usage** – Please prevent mechanical stress to the light surface during operation. This will lead to an inhomogeneous light emission.
6. **Cleaning** – The light emission surface has to be cleaned with a standard glass cleaner and a soft cleaning cloth. Do not use other material for cleaning as it will damage the device.

03200.07 Manual MBJ High Power HP-Series, August 2023

MBJ Imaging GmbH

Jochim-Klindt-Straße 7 +49 4102 778 90 - 31
22926 Ahrensburg, Germany sales@mbj-imaging.com
www.mbj-imaging.com

High Power Series



Model Sizes in Series

The light is available in the following sizes ¹⁾		
High Power WBL-0410	High Power SRL-10	High Power SL-Narrow
High Power WBL-0420	High Power SRL-12	High Power SL-Wide
High Power WBL-0430		

1) Size definition: High Power WBL-0420 refers to a wide bar with a light field of 45 mm x 200 mm, High Power SRL-12 refers to a ring light with a outside light field diameter of 121 mm, Narrow/Wide refers to the light beam opening angle.

Possible LED Colors

LED	Abbr. ¹⁾	Peak Wavelength ²⁾
White	-WT	5000 K, min. CRI70
Red	-RD	near 634 nm
Infrared	-IR	near 850 nm

1) Color option will be added to the model name after the size information. High Power WBL-0420-RD refers to a backlight with 634 nm red light.

2) This is an approximated value. The exact value also depends on LED temperature and LED current.

Electrical Connection

The lighting is equipped with an 5 pin M12x1 connector.

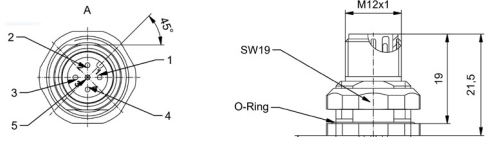

Pin	Color ¹⁾	Standard (-s)	Direct (-x) ²⁾
1	brown	24 VDC	LED (+)
2	white	Dim	LED (+)
3	blue	Trigger	LED (-)
4	black	Ground	LED (-)
5	green- yellow	not used	not used

1) Wire color of MBJ lighting cable

2) Connection to 24VDC without external LED controller may destroy the unit

Additional Information:

Pin 3 (Trigger) is an 'active high' input signal with 5...24V=ON and 0...1V=OFF, it is a high resistance current sink with 0.2 mA for 5V and 5 mA for 24V
Pin 2 (DIM) is used as brightness control and operation mode switch, it is a high resistance current sink with 0.2 mA for 5V and 1 mA for 24V.

For the connection it is recommended to use the MBJ lighting cable with a maximum length of 10 m.

Integrated Controller (-s)

Supported operation modes with the integrated LED controller

Pin 2 (Dim)	Operation mode
24V	steady light ¹⁾
1...10V	steady light with brightness control ²⁾
24V	triggered light
GND	triggered flash light with max. 20 ms and up-to 100% more light intensity ³⁾

1) Pin 3 (Trigger) needs permanent 24V to activate steady light mode.

2) PWM with 3.8 kHz clock is used, recommended minimal camera exposure is 5 ms.

3) Latency between trigger and LED light ON is about max. 30µs, the maximum recommended clock speed is 1 kHz, the maximum recommended duty cycle is 25% and the minimum recommended flash time is 100 µs.

Specification	HP WBL-0410 / HP WBL-0410-IP	HP WBL-0420 / HP WBL-0420-IP	HP WBL-0430 / HP WBL-0430-IP	HP SRL-10 / HP SRL-10-IP	HP SRL-12 / HP SRL-12-IP	HP SL-Narrow	HP SL-Wide
Optical parameter							
Luminous area (AxB) or (ID - OD)	45 mm x 100 mm	45 mm x 200 mm	45 mm x 300 mm	67 mm - 101 mm	87 mm - 121 mm		
Beam Angle FWHM						13°	26°
Light emission	Rectangular or ring shaped light field with direct fired LED and 20° focussing beam					Spotlight with direct light emission and different beam angles	
Recommended use	Commonly used as incident light for long distance objects, e.g. for barcode reading at narrow spaces					Used in various applications for bright field with long distance or small FOV size	
Recommended light working distance	100 mm - 700 mm	100 mm - 900 mm	150 mm - 1000 mm	250 mm - 700 mm	250 mm - 750 mm	100 mm - 700 mm	50 mm - 500 mm
Electrical parameter							
Available interfaces	-s with integrated LED Controller and 4 operation modes; -x with direct LED access (external LED control is required)						
U _{in} for -s Version	24 VDC +/- 5%						
ULed(+) range for -x version ²⁾	WT: 17 ... 20 VDC; RD: 12 ... 15 VDC; IR: 9 ... 12 VDC					WT: 12.0... 13.5 VDC; RD: 9.5 ... 11 VDC; IR: 12..13.5 VDC	
Typical Power (-s version)							
Steady light operation (white / red / IR) ³⁾	11 W / 8 W / 6 W	23 W / 16 W / 12 W	32 W / 26 W / 18 W	11 W / 8 W / 6 W	16 W / 12 W / 9 W	9 W / 6 W / 9 W	9 W / 6 W / 9 W
During ON time at flashed light operation ⁴⁾	25 W	49 W	74 W	30 W	44 W	20 W	20 W
Recommended LED current (-x version)							
Steady light (100% duty cycle)	600 mA (900 mA for IR)	1200 mA (1800 mA for IR)	1800 mA (2000 mA for IR)	600 mA (900 mA for IR)	900 mA (1200 mA for IR)	600 mA (600 mA for IR)	600 mA (600 mA for IR)
Flash light (50% duty cycle, <500 ms pulse)	1200 mA (1350 mA for IR)	2400 mA (2700 mA for IR)	3600 mA (4050 mA for IR)	1200 mA (1350 mA for IR)	1800 mA (1800 mA for IR)	900 mA (900 mA for IR)	900 mA (900 mA for IR)
Flash light (25% duty cycle, <50 ms pulse)	1800 mA (2025 mA for IR)	3600 mA (4050 mA for IR)	5400 mA (6075 mA for IR)	1800 mA (2025 mA for IR)	2700 mA (2700 mA for IR)	1200 mA (1200 mA for IR)	1200 mA (1200 mA for IR)
Flash light (10% duty cycle, <5 ms pulse)	2400 mA (2700 mA for IR)	4800 mA (5400 mA for IR)	7200 mA (8100 mA for IR)	2400 mA (2700 mA for IR)	3600 mA (3600 mA for IR)	1500 mA (1500 mA for IR)	1500 mA (1500 mA for IR)
General parameter							
Dimension (H x W x D)	54 mm x 110 mm x 23 mm	54 mm x 210 mm x 23 mm	54 mm x 310 mm x 23 mm	110 mm x 121 mm x 14 mm	130 mm x 141 mm x 14 mm	56 mm x 46 mm x 46 mm	56 mm x 46 mm x 46 mm
Weight	250 g	450 g	650 g	225 g	350 g	200 g	200 g
Material	Anodized aluminum housing with PMMA light cover						
Connector	M12x1 socket, 5 pin, male (pinning details on the next page)						
Accessories	For cable, foil holder brackets, light manipulation foils and external LED controller: please check www.mbj-imaging.com						

1) Values are approximate with a +/- 7% tolerance

2) Lower voltage value refers to steady light, higher voltage value refers to flash light, please see max. allowed current in the rows below.

3) Power for Blue / Yellow is comparable to White, Power for Green is approx. 1,2 times higher

4) Triggered flash light with max. 20 ms and up to 100% more light intensity, calculated for White.

Application Samples for (-s) controller

