



Technical Details



ViC 43GX676 Technical Reference Manual



1. Quick Facts	5
2. Dimensional Diagrams	7
2.1 ViC 43GX676 C-Mount without Tripod Adapter	7
3. I/O Connector	8
3.1 6-pin I/O Connector	8
3.1.1 TRIGGER_IN Electrical Characteristics	8
3.1.2 GPIO0/GPIO1 Electrical Characteristics	9
4. Spectral Characteristics	10
4.1 Spectral Sensitivity - IMX676	10
5. Camera Controls	11
5.1 Sensor Readout Control	11
5.1.1 Pixel Format	11
5.1.1.1 8-Bit Bayer Raw	12
5.1.1.2 12-Bit Packed Bayer Raw	12
5.1.1.3 16-Bit Bayer Raw	12
5.1.1.4 YUV 4:2:2	12
5.1.1.5 YUV 4:1:1	13
5.1.1.6 RGB24	13
5.1.1.7 8-Bit Monochrome	13
5.1.2 Resolution	13
5.1.3 Readout Modes	14
5.1.4 Frame Rate	15
5.1.5 Partial Scan Offset	17
5.1.6 Image Flipping	18
5.2 Image Sensor Control	19
5.2.1 Exposure Time	19
5.2.2 Gain	19
5.2.3 Black Level	19
5.3 Automatic Exposure and Gain Control	20
5.3.1 Auto Exposure	20
5.3.2 Auto Gain	21
5.3.3 Auto Reference Value	21
5.3.4 Highlight Reduction	21
5.3.5 Auto Exposure Limits	22
5.3.6 Auto Gain Limits	22
5.4 Trigger	23
5.4.1 Trigger Mode	23
5.4.2 Trigger Polarity	23
5.4.3 Software Trigger	24
5.4.4 Trigger Burst Count	24



5.4.5	Trigger Source	25
5.4.6	Trigger Overlap	25
5.4.7	Trigger Delay	25
5.5	Trigger Timing Parameters	26
5.5.1	Trigger Debounce Time	26
5.5.2	Trigger Mask Time	26
5.5.3	Trigger Noise Suppression Time	27
5.6	Digital I/O	27
5.6.1	Line Selector	27
5.6.2	Line Name	28
5.6.3	Line Mode	28
5.6.4	Line Inverter	28
5.6.5	Line Status	29
5.6.6	Line Status Invalidate	29
5.6.7	Line Source	29
5.6.8	Line Format	30
5.6.9	User Output Selector	30
5.6.10	User Output Value	30
5.7	Strobe	31
5.7.1	Strobe Enable	31
5.7.2	Strobe Polarity	31
5.7.3	Strobe Operation	31
5.8	White Balance	32
5.8.1	Auto White Balance	32
5.8.2	White Balance Mode	32
5.8.3	Manual White Balance	33
5.9	Image Processing	35
5.9.1	Gamma	35
5.9.2	Lookup Table	36
5.10	Color Processing	37
5.10.1	Hue	37
5.10.2	Saturation	38
5.10.3	Color Correction Matrix	38
5.11	Region of Interest for Auto Functions	41
5.11.1	Auto Functions ROI Enable	41
5.11.2	Auto Functions ROI Preset	41
5.11.3	Auto Functions ROI Custom Rectangle	42
5.12	User Sets	43
5.12.1	User Set Selector	43
5.12.2	Load User Set	44
5.12.3	Save User Set	44
5.12.4	Default User Set	44
5.13	Timestamp Control	44



Table of Contents

5.13.1	Timestamp Latch	45
5.13.2	Timestamp Latch Value	45
5.13.3	Timestamp Latch String	45
5.13.4	Timestamp Reset	45
5.14	Precision Time Protocol	46
5.14.1	PTP Enable	46
5.14.2	PTP Status	46
5.15	Action Scheduler	47
5.15.1	Action Selector	47
5.15.2	Action Scheduler Time	47
5.15.3	Action Scheduler Interval	48
5.15.4	Action Scheduler Commit	48
5.15.5	Action Scheduler Cancel	48
5.16	Events	49
5.16.1	Event Selector	49
5.16.2	Event Notification	49
5.16.3	Event Frame Trigger Missed	50
5.16.4	Event Line1 Falling Edge	50
5.16.5	Event Line1 Rising Edge	51
5.16.6	Event Test	51
5.17	Bandwidth Control	52
5.17.1	Device Link Throughput Limit Mode	52
5.17.2	Device Link Throughput Limit	52
6.	Status LEDs	54
6.1	LEDs on the RJ45 Connector	54
7.	Revision History	55



1 Quick Facts

General	
Vision Standard	GigE Vision
Dynamic Range	12 bit
Resolution	3536x3536
Frame Rate at Full Resolution	9
Pixel Formats	8-Bit Bayer (RG) 12-Bit Bayer Packed (RG) 16-Bit Bayer (RG) YUV 4:2:2 YUV 4:1:1 YUV 4:1:1 RGB24 8-Bit Monochrome 12-Bit Packed Monochrome 16-Bit Monochrome

Optical Interface	
IR-Cut filter	No
Sensor Type	Sony IMX676
Shutter Type	Rolling
Sensor Format	1/1.6 inch
Pixel Size	2.0 μm
Lens Mount	C

Electrical Interface	
Interface	GigE
Supply Voltage	8 VDC to 25 VDC or PoE: 48 VDC to 56 VDC
Current Consumption (DC)	approx 170 mA @ 12 VDC
Power Consumption (PoE)	approx 2.6 W PoE

Mechanical Data	
Dimensions	H: 29 mm, W: 29 mm, L: 44 mm
Mass	63 g



Adjustments	
Shutter	50 μ s to 1 s
Gain	0 dB to 72 dB

Environmental Conditions	
Housing Temperature (operating)	0 °C to 55 °C
Temperature (storage)	-20 °C to 80 °C
Humidity (operating)	20 % to 80 % (non-condensing)
Humidity (storage)	20 % to 95 % (non-condensing)



2 Dimensional Diagrams

2.1 ViC 43GX676 C-Mount without Tripod Adapter

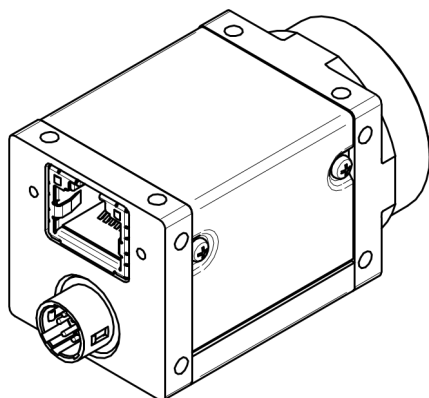
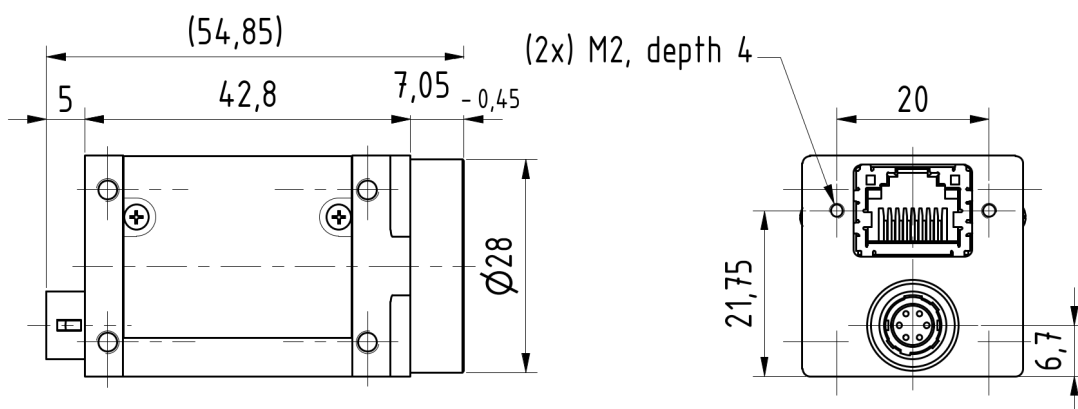
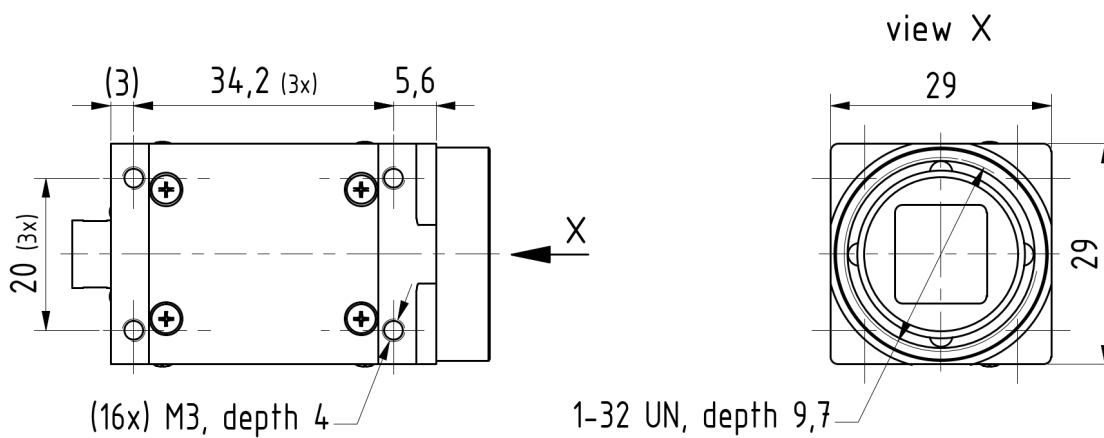

Scale: 1 : 1
 Dimensions: mm
 Tolerances: DIN ISO 2768-m
 310-24-03-00-00-b



3 I/O Connector

3.1 6-pin I/O Connector

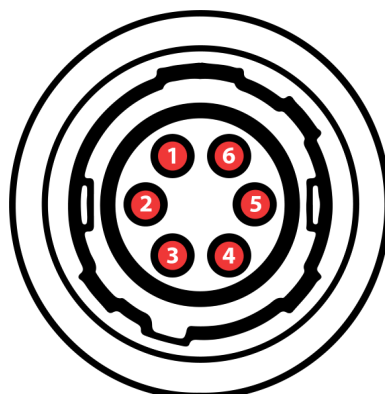

Rear view of camera

Pin	Signal	Type	Remarks	LineSelector
1	Power Supply	Power	8V - 25V	
2	TRIGGER_IN (+)	Input	Optocoupler signal	Line1 ¹
3	TRIGGER_IN (-)	Ground	Optocoupler ground	
4	GPIO0	Input/Output ²	Open drain output or TTL input	Line0 ¹
5	GPIO1	Input/Output ²	Open drain output or TTL input	Line2 ¹
6	GND	Ground	Power and GPIO Ground	

¹ Set [Line Selector](#) accordingly to configure or query this pin.

² Direction for GPIO0/GPIO1 can be changed via [Line Mode](#).

The part number of this Hirose connector is HR10A-7R-6P(73). To create an I/O cable you need a Hirose connector HR10A-7P-6S(73).

3.1.1 TRIGGER_IN Electrical Characteristics

Parameter	Condition	Min	Max
Input Logic Low Voltage			1.3 V
Input Logic High Voltage		3.2 V	25 V
Input Current	$V_{IN} = 0 V$		0 mA
Input Current	$V_{IN} = 12 V$	3.5 mA	6 mA



3.1.2 GPIO0/GPIO1 Electrical Characteristics

When configured as an input, the voltage and current limits are as follows:

Parameter	Condition	Min	Max
Input Logic Low Voltage			0.4 V
Input Logic High Voltage		1.9 V	25 V
Input Current	$V_{IN} = 0 \text{ V}$		-0.6 mA
Input Current	$V_{IN} = 3 \text{ V}$		0 mA

When configured as an output, the GPIO pin is an open drain:

Parameter	Condition	Min	Max
Output Logic Low Voltage	$I_{IN} = 0.2 \text{ A}$		0.2 V
Output Logic High Voltage	External pull-up resistor		25 V
Input Current			0.2 A



4 Spectral Characteristics

4.1 Spectral Sensitivity - IMX676

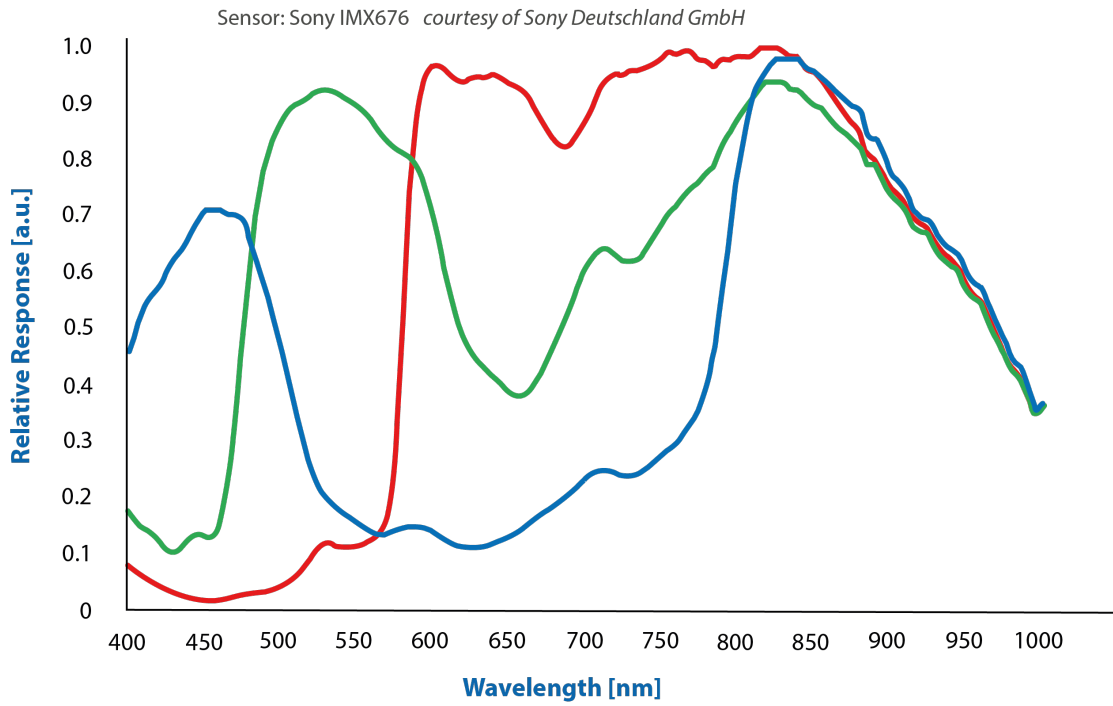



5 Camera Controls

This section describes the parameters available for the ViC 43GX676 camera.

The actual name of the parameter depends on the driver technology used to access the camera. Parameter names are listed for the most common ways to access the cameras:

- *GigE Vision (IC Imaging Control 4, or via 3rd party driver)*
- *IC Imaging Control 3.x (on Windows, via Device Driver for The Imaging Source GigE Cameras)*

5.1 Sensor Readout Control

5.1.1 Pixel Format

The pixel format defines the data type of the pixels transmitted to the computer. The bits per pixel needed for a particular pixel format influence the required bandwidth.

The driver technology used to access the camera significantly impacts the way the pixel format is controlled:

- When using *IC Imaging Control 4* or *GigE Vision*, the pixel format is controlled through the `PixelFormat GenICam` feature.
- When using *IC Imaging Control 3.x*, the pixel format is part of the video format - a parameter which combines pixel format, resolution and readout mode. For more information, refer to the *IC Imaging Control 3.x* documentation sections on `VideoFormat` and `VideoFormatDesc`.

The ViC 43GX676 color camera supports multiple pixel formats with variable bits-per-pixel settings. The names of the pixel formats and the way to select them depends on the driver used to control the camera. The following table contains a short overview of all possible formats followed by a more detailed description.

Pixel Format	Bits Per Pixel	GigE Vision	TIS GigE Driver
8-Bit Bayer (RG)	8	BayerRG8	RGB32, Y800
12-Bit Packed Bayer (RG)	12	BayerRG12p	RGB64, Y16
16-Bit Bayer (RG)	16	BayerRG16	RGB64, Y16
YUV 4:2:2	16	YUV422_8	YUY2
YUV 4:1:1 (a)	12	YCbCr411_8	
YUV 4:1:1 (b)	12	YCbCr411_8_CbYYCrYY	Y411
RGB24	24	BGR8	RGB24
8-Bit Monochrome	8	Mono8	



5.1.1.1 8-Bit Bayer Raw

This format transmits data using one byte for each pixel.

GigEVision drivers see this pixel format as one of the 8-bit bayer raw formats (`BayerGR8`, `BayerRG8`, `BayerGB8`, `BayerBG8`).

The *Device Driver for The Imaging Source GigE Cameras* simplifies this variety of possible pixel formats and offers two video formats instead: `RGB32` and `Y800`. The `RGB32` format results from the driver's automatic debayering of the raw image data, while the `Y800` format contains the raw data which is reinterpreted as monochrome.

5.1.1.2 12-Bit Packed Bayer Raw

This format transmits data using 3 bytes for each pair of 2 consecutive pixels.

GigEVision drivers see this pixel format as one of the 12-bit packed bayer raw formats (`BayerGR12Packed`, `BayerRG12Packed`, `BayerGB12Packed`, `BayerBG12Packed`).

The *Device Driver for The Imaging Source GigE Cameras* simplifies this variety of possible pixel formats and offers two video formats instead: `RGB64` and `Y16`. The `RGB64` format results from the driver's automatic debayering of the raw image data, while the `Y16` format contains the raw data which is reinterpreted as monochrome. Since the ViC 43GX676 camera offers both 12-bit packed and 16-bit bayer raw pixel formats, the driver uses the 12-bit packed format when the `RGB64` or `Y16` video format is selected.

5.1.1.3 16-Bit Bayer Raw

This format transmits data using 2 bytes for each pixel.

The sensor of the ViC 43GX676 camera is not able to provide 16-bit data output. The pixel data is transmitted in the most significant bits. This allows application programs to ignore the sensor-specific data type and to treat the data as if the sensor outputs 16 bits.

GigEVision drivers see this pixel format as one of the 16-bit packed bayer raw formats (`BayerGR16`, `BayerRG16`, `BayerGB16`, `BayerBG16`).

The *Device Driver for The Imaging Source GigE Cameras* simplifies this variety of possible pixel formats and offers two video formats instead: `RGB64` and `Y16`. The `RGB64` format results from the driver's automatic debayering the raw image data, while the `Y16` format contains the raw data which is reinterpreted as monochrome.

5.1.1.4 YUV 4:2:2

This format transmits an 8-bit luminance value for every pixel and a pair of chrominance values for every two pixels.

The camera converts the raw pixel data from the sensor to YUV 4:2:2. Since YUV 4:2:2 averages to 2 bytes per pixel, the YUV 4:2:2 pixel format requires two times the bandwidth of the 8-bit raw format, thus reducing the maximum possible frame rate.

GigEVision drivers see this pixel format as `YUV422_8`.



The *Device Driver for The Imaging Source GigE Cameras* offers this pixel format as the YUY2 video format.

5.1.1.5 YUV 4:1:1

This format transmits an 8-bit luminance value for every pixel and a pair of chrominance values for every four pixels.

The two YUV 4:1:1 pixel formats only differ in their byte order.

The camera converts the raw pixel data from the sensor to YUV 4:2:2. Since YUV 4:2:2 averages to 1.5 bytes per pixel, the YUV 4:2:2 pixel format requires two 50% more bandwidth than the 8-bit raw format, thus reducing the maximum possible frame rate.

GigEVision drivers see this pixel format as YCbCr411_8 and YCbCr411_8_CbYYCrYY.

The *Device Driver for The Imaging Source GigE Cameras* offers this pixel format as the Y411 video format.

5.1.1.6 RGB24

The camera converts the raw pixel data from the sensor to RGB24. Since RGB24 uses 3 bytes to store 1 pixel, the RGB24 pixel format requires three times the bandwidth of the 8-bit raw format, thus reducing the maximum possible frame rate.

GigEVision drivers enumerate this pixel format as BGR8.

The *Device Driver for The Imaging Source GigE Cameras* enumerates this pixel format as the RGB24 video format.

5.1.1.7 8-Bit Monochrome

The camera generates the pixel data by debayering the raw pixel data and transmitting only the luminance information.

GigEVision drivers enumerate this pixel format as Mono8.

5.1.2 Resolution

The ViC 43GX676 allows the user to specify which rectangular region of the image sensor to read out during camera operation. The size of this rectangle determines the number of pixels that have to be transferred for each frame and has a significant influence on the required network bandwidth.

Lowering the resolution also often allows the image sensor to operate at a higher frame rate. Changes in the vertical resolution have more effect on the maximum frame rate than changes in the horizontal direction.

The way the resolution is controlled varies greatly between the driver technology used to access the camera:

- When using *GigE Vision*, the resolution is controlled through the GenICam features Width and Height.



- When using *IC Imaging Control*, the resolution is part of the video format, a parameter that combines pixel format, resolution and readout mode. For more information, refer to the *IC Imaging Control* documentation sections on `VideoFormat` and `VideoFormatDesc`.

Parameter	Horizontal Resolution
Minimum	256
Maximum	3536
Increment	16
GigEVision: GenICam	Width
Type	Integer

Parameter	Vertical Resolution
Minimum	256
Maximum	3536
Increment	4
GigEVision: GenICam	Height
Type	Integer

5.1.3 Readout Modes

The ViC 43GX676 camera offers different sensor readout modes.

By default, the camera outputs all pixels of the image sensor.

In *binning* modes, a number of neighboring pixels is merged into one output pixel during readout. The nature of this merge operation is sensor-specific, most sensors either add the pixel values or average them.

The way the readout modes are controlled depends greatly upon which driver technology is used to access the camera:

- When using *GigE Vision*, the readout mode is controlled through the *GenICam* features `DecimationHorizontal`, `DecimationVertical`, `BinningHorizontal` and `BinningVertical`.
- When using *IC Imaging Control*, the readout mode is part of the video format - a parameter that which combines pixel format, resolution and readout mode. For more information, refer to the *IC Imaging Control* documentation sections on `VideoFormat` and `VideoFormatDesc`.

The following readout modes are supported:

- Default
- Binning 2X



Parameter	Binning Horizontal
Valid Values	1, 2
GigEVision: GenICam	BinningHorizontal
Type	Integer

Parameter	Binning Vertical
Valid Values	1, 2
GigEVision: GenICam	BinningVertical
Type	Integer

5.1.4 Frame Rate

The frame rate is specified in frames per second and determines the camera's operating speed.

The way the frame rate is controlled depends greatly upon which driver technology is used to access the camera:

- When using *GigEVision*, the frame rate is controlled through the *GenICam* feature `AcquisitionFrameRate`.
- When using IC Imaging Control, the frame rate is selected from a list of available frame rates through APIs such as `Grabber::setFPS` or `ICImagingControl.DeviceFrameRate`.

The range of available frame rates depends upon other camera settings such as well, pixel format, resolution and readout modes.

Parameter	Frame Rate
Minimum	Depending on Pixel Format, Resolution, and Readout Mode
Maximum	Depending on Pixel Format, Resolution, and Readout Mode
GigEVision: GenICam	<code>AcquisitionFrameRate</code>
Type	Float

Please note: Enabling [Device Link Throughput Limit Mode](#) can limit the frame rate below the configured value.

The following tables show the maximum frame rate for some combinations of pixel format and resolution.

8-Bit Bayer Raw



Width	Height	Maximum Frame Rate
3536	3536	9
1920	1080	43
640	480	71

12-Bit Packed Bayer Raw

Width	Height	Maximum Frame Rate
3536	3536	6
1920	1080	28
640	480	71

16-Bit Bayer Raw

Width	Height	Maximum Frame Rate
3536	3536	4
1920	1080	21
640	480	63

YUV 4:2:2

Width	Height	Maximum Frame Rate
3536	3536	4
1920	1080	21
640	480	63

YUV 4:1:1 (a)

Width	Height	Maximum Frame Rate
3536	3536	6
1920	1080	28
640	480	71

YUV 4:1:1 (b)



Width	Height	Maximum Frame Rate
3536	3536	6
1920	1080	28
640	480	71

RGB24

Width	Height	Maximum Frame Rate
3536	3536	3
1920	1080	14
640	480	42

8-Bit Monochrome

Width	Height	Maximum Frame Rate
3536	3536	9
1920	1080	43
640	480	71

5.1.5 Partial Scan Offset

If the selected resolution is smaller than the sensor size, the part of the sensor that is actually read out can be specified by the *Partial Scan Offset X* and *Partial Scan Offset Y* parameters. By default, the camera automatically positions the offsets so that the center of the sensor is used.

Parameter	Partial Scan Offset X
Minimum	0
Maximum	3280
Increment	8
GigEVision: GenICam	OffsetX
Type	Integer
VCD Property	VCDID_PartialScanOffset \VCDElement_PartialScanOffsetX



Parameter	Partial Scan Offset Y
Minimum	0
Maximum	3280
Increment	4
GigEVision: GenICam	OffsetY
Type	Integer
VCD Property	VCDID_PartialScanOffset \VCDElement_PartialScanOffsetY

If *Partial Scan Offset X* or *Partial Scan Offset Y* is configured to a value that would be invalid with the current setting of [Resolution](#) setting, the camera uses the maximum possible value.

Parameter	Partial Scan Auto Center
On	Automatically configure Partial Scan Offset X/Y so that the center area of the sensor is read out
True	
Off	Control Partial Scan Offset X/Y manually
False	
GigEVision: GenICam	OffsetAutoCenter
Type	Boolean
VCD Property	VCDID_PartialScanOffset \VCDElement_PartialScanAutoCenter

5.1.6 Image Flipping

The ViC 43GX676 camera allows flipping of the image data horizontally, vertically, or both. The *Flip Horizontal* and *Flip Vertical* parameters can be used to control this sensor feature.

Parameter	Flip Horizontal
True	Image data is flipped horizontally
False	Image data is not flipped horizontally
GigEVision: GenICam	ReverseX
Type	Boolean
VCD Property	VCDID_FlipHorizontal\VCDElement_Value



Parameter	Flip Vertical
True	Image data is flipped vertically
False	Image data is not flipped vertically
GigEVision: GenICam	ReverseY
Type	Boolean
VCD Property	VCDID_FlipVertical\VCDElement_Value

5.2 Image Sensor Control

5.2.1 Exposure Time

The *Exposure Time* parameter defines the time the camera opens its (electronic) shutter when it is taking an image.

Parameter	Exposure Time
Minimum	50 μ s
Maximum	1 s
Default	auto
GigEVision: GenICam	ExposureTime
Type	Float
VCD Property	VCDID_Exposure\VCDElement_Value

5.2.2 Gain

The *Gain* parameter defines the amplification that is applied to the image at sensor level.

Parameter	Gain
Minimum	0 dB
Maximum	72 dB
Default	auto
GigEVision: GenICam	Gain
Type	Float
VCD Property	VCDID_Gain\VCDElement_Value

5.2.3 Black Level

The *Black Level* parameter defines the lowest possibly intensity value of the image sensor.



Parameter	Black Level
Minimum	0
Maximum	4095
Default	0
GigEVision: GenICam	BlackLevel
Type	Float
VCD Property	VCDID_Brightness\VCDElement_Value

5.3 Automatic Exposure and Gain Control

The ViC 43GX676 camera can automatically control gain and exposure time. These automatic functions are enabled by default.

In order to optimize image parameters, a region of interest can be specified for automatic functions. Specifying a region of interest enables fine-grained control over the image area for which the image parameters are optimized. A selection of pre-defined area presets is available, but the user can also specify the coordinates of a custom rectangle.

In certain situations, it is desirable to limit the range of the auto-controlled parameters. For example, one might want to avoid high gain settings in order to keep noise levels low. Other applications require limiting the maximum exposure time so that movements do not get blurred. Therefore, the ranges of the gain and exposure parameter can be limited.

If both auto exposure and auto gain are active, the camera tries to lower the gain value in order to reduce noise and improve the image quality.

5.3.1 Auto Exposure

Parameter	Auto Exposure
Continuous	Enable Auto Exposure
True	
Off	Disable Auto Exposure
False	
GigEVision: GenICam	ExposureAuto
Type	Enumeration
VCD Property	VCDID_Exposure\VCDElement_Auto



5.3.2 Auto Gain

Parameter	Auto Gain
Continuous	Enable Auto Gain
True	
Off	Disable Auto Gain
False	
GigEVision: GenICam	GainAuto
Type	Enumeration
VCD Property	VCDID_Gain\VCDElement_Auto

5.3.3 Auto Reference Value

The *Auto Reference Value* parameter specifies the target brightness for both auto exposure and auto gain.

Parameter	Auto Reference Value
Minimum	0
Maximum	255
Default	96
GigEVision: GenICam	ExposureAutoReference
Type	Integer
VCD Property	VCDID_Exposure\VCDElement_AutoReference

5.3.4 Highlight Reduction

Enabling *Highlight Reduction* lets the auto exposure and auto gain functions reduce overexposed areas in the output image. This feature is particularly useful when using 10/12/16-bit output images and a tone mapping algorithm in post-processing when using higher bit depths as the dark areas still contain a lot of useful information.

Parameter	Highlight Reduction
True	Try to reduce overexposed areas
False	Ignore overexposed areas and focus on matching the image brightness to the selected Auto Reference Value .
GigEVision: GenICam	ExposureAutoHighlightReduction
Type	Boolean
VCD Property	VCDID_HighlightReduction\VCDElement_Value



5.3.5 Auto Exposure Limits

The *Auto Exposure Lower Limit* parameter determines the minimum possible value that can be set by the auto exposure algorithm.

Parameter	Auto Exposure Lower Limit
Minimum	50 μ s
Maximum	1 s
GigE Vision: GenICam	ExposureAutoLowerLimit
Type	Float

The *Auto Exposure Upper Limit* parameter determines the maximum possible value that can be set by the auto exposure algorithm.

Parameter	Auto Exposure Upper Limit
Minimum	50 μ s
Maximum	1 s
GigE Vision: GenICam	ExposureAutoUpperLimit
Type	Float
VCD Property	VCDID_Exposure\VCDElement_AutoMaxValue

If the *Auto Exposure Upper Limit Auto* parameter is enabled, the value of *Auto Exposure Upper Limit* is automatically kept at the maximum possible value for the current frame rate.

Parameter	Auto Exposure Upper Limit Auto
On	Select <i>Auto Exposure Upper Limit</i> automatically
Off	Let the user control <i>Auto Exposure Upper Limit</i>
GigE Vision: GenICam	ExposureAutoUpperLimitAuto
Type	Enumeration
VCD Property	VCDID_Exposure\VCDElement_AutoMaxValueAuto

5.3.6 Auto Gain Limits

The *Auto Gain Lower Limit* parameter determines the minimum possible value that can be set by the auto gain algorithm.



Parameter	Auto Gain Lower Limit
Minimum	0 dB
Maximum	72 dB
GigEVision: GenICam	GainAutoLowerLimit
Type	Float

The *Auto Gain Upper Limit* parameter determines the maximum possible value that can be set by the auto gain algorithm.

Parameter	Auto Gain Upper Limit
Minimum	0 dB
Maximum	72 dB
GigEVision: GenICam	GainAutoUpperLimit
Type	Float

5.4 Trigger

The trigger mode can be used to take images at very specific points in time which are specified by an electrical signal connected to the TRIGGER_IN pin of the I/O connector of the camera.

5.4.1 Trigger Mode

The *Trigger Mode* parameter enables the trigger mode.

Parameter	Trigger Mode
On	Enable Trigger Mode
True	
Off	Disable Trigger Mode
False	
GigEVision: GenICam	TriggerMode
Type	Enumeration
VCD Property	VCDID_Trigger\VCDElement_Value

5.4.2 Trigger Polarity

The *Trigger Polarity* parameter controls whether a trigger event is accepted on the rising or falling edge of the signal connected to the TRIGGER_IN line.



Parameter	Trigger Polarity
RisingEdge	Accept rising edge as trigger signal
True	
FallingEdge	Accept falling edge as trigger signal
False	
GigEVision: GenICam	TriggerActivation
Type	Enumeration
VCD Property	VCDID_Trigger\VCDElement_Polarity

5.4.3 Software Trigger

The *Software Trigger* function can be used to simulate a trigger pulse, in turn causing one image to be exposed and delivered to the host computer.

Parameter	Software Trigger
Execute	Simulate one trigger pulse
GigEVision: GenICam	TriggerSoftware
Type	Command
VCD Property	VCDID_Trigger\VCDElement_SoftwareTrigger

5.4.4 Trigger Burst Count

The *Trigger Burst Count* parameter allows the camera to be configured to take more than one image per trigger pulse. By default, this parameter is set to 1 so that exactly one image is acquired. The images are taken as rapidly as possible given current settings (i.e. as limited by the current exposure time and frame rate settings).

Parameter	Trigger Burst Count
Minimum	1
Maximum	65535
Default	1
GigEVision: GenICam	AcquisitionBurstFrameCount
Type	Integer
VCD Property	VCDID_Trigger\VCDElement_TriggerBurstCount



5.4.5 Trigger Source

The *Trigger Source* parameter allows the camera to be configured to only accept trigger signals from a specified source, e.g. only software trigger.

Parameter	Trigger Source
Any	Allow trigger signals from any source
Line1	Allow only hardware trigger
Software	Allow only software trigger
GigEVision: GenICam	TriggerSource
Type	Enumeration

5.4.6 Trigger Overlap

The *Trigger Overlap* feature gives information on when a new trigger pulse is accepted in the trigger -> exposure -> readout sequence.

Parameter	Trigger Overlap
Off	The next trigger pulse is only accepted once the previous frame has been read out from the sensor
Readout	The next trigger pulse is accepted during readout as long as the remaining readout time is shorter than the exposure time
GigEVision: GenICam	TriggerOverlap
Type	Enumeration
VCD Property	VCDID_Trigger\VCDElement_TriggerOverlap

5.4.7 Trigger Delay

The *Trigger Delay* parameter specifies a time for which the camera waits between receiving a trigger signal and starting the exposure of an image. Simulated trigger pulses generated through the *Software Trigger* function are not delayed by this parameter.

Parameter	Trigger Delay
Minimum	Dynamic, as low as 304.5 μ s
Maximum	1 s
GigEVision: GenICam	TriggerDelay
Type	Float
VCD Property	VCDID_Trigger\VCDElement_TriggerDelay



Dynamic minimum: The minimum value depends on other settings such as [Exposure Time](#), *Width*, *PixelFormat*, and [Trigger Polarity](#).

5.5 Trigger Timing Parameters

The Visus series offers several options for dealing with bad trigger signals. By using the *Debounce Time*, *Denoise Time* and *Mask Time* parameters, the camera can be configured to ignore pulses on its TRIGGER_IN line under certain conditions.

Useful values for these parameters are application-specific. They depend on the expected trigger frequency, the exposure time and assumptions about the input signal quality.

The default values for all these parameters is 0 μ s, assuming perfect signal quality.

5.5.1 Trigger Debounce Time

The *Trigger Debounce Time* parameter specifies the time for which the trigger input has to be low in order for the next trigger signal to be accepted.

Parameter	Trigger Debounce Time
Minimum	0 s
Maximum	1 s
Default	0 s
GigEVision: GenICam	TriggerDebouncer
Type	Float
VCD Property	VCDID_Trigger\VCDElement_TriggerDebouncer

5.5.2 Trigger Mask Time

The *Trigger Mask Time* parameter specifies the time for which trigger pulses are ignored after accepting a trigger signal.

Parameter	Trigger Mask Time
Minimum	0 s
Maximum	1 s
Default	0 s
GigEVision: GenICam	TriggerMask
Type	Float
VCD Property	VCDID_Trigger\VCDElement_TriggerMask



5.5.3 Trigger Noise Suppression Time

The *Trigger Noise Suppression Time* parameter specifies the time for which trigger input has to be active in order to be accepted as a trigger signal.

Parameter	Trigger Noise Suppression Time
Minimum	0 s
Maximum	1 s
Default	0 s
GigEVision: GenICam	TriggerDenoise
Type	Float
VCD Property	VCDID_Trigger\VCDElement_TriggerDenoise

5.6 Digital I/O

Visus series cameras have one digital input and two general purpose input/outputs pins.

The digital input can be used as a [Trigger](#) input, and the current status can also be examined directly.

The general-purpose input/output pins can be configured using [Line Mode](#) to either act as an input that can be read using [Line Status](#), or as an open-drain output whose value is defined by [Line Source](#) and [Line Inverter](#).

By setting Line Source of an output to `ExposureActive`, it can signal the exact moment when the image sensor is sensitive to light so that external light sources can be synchronized to its operation cycle.

See [I/O Connector](#) for a description of the electric properties of the I/O connector.

5.6.1 Line Selector

The *Line Selector* feature selects the physical line (or pin) of the external device connector to configure.

Parameter	Line Selector
Line0	Select Line 0
Line1	Select Line 1
Line2	Select Line 2
GigEVision: GenICam	LineSelector
Type	Enumeration

If a line is selected, all other Line* features will be applied to its associated device pin:



- [Line Name](#)
- [Line Mode](#)
- [Line Inverter](#)
- [Line Status](#)
- [Line Status Invalidate](#)
- [Line Source](#)
- [Line Format](#)

5.6.2 Line Name

Line Name returns the name of the line selected by [Line Selector](#).

Parameter	Line Name
GigEVision: GenICam	LineName
Type	String

5.6.3 Line Mode

Line Mode is a feature indicating the direction of the line selected by [Line Selector](#).

The direction for `Line0` and `Line2` can be changed, while `Line1`'s direction is always `Input`.

Parameter	Line Mode
Input	The selected line is an input.
Output	The selected line is an output.
GigEVision: GenICam	LineMode
Type	Enumeration

5.6.4 Line Inverter

The *Line Inverter* feature can be used to invert the output signal of the line selected by [Line Selector](#).

Line Inverter is only available if the [Line Mode](#) of the selected line is set to `Output`.

Parameter	Line Inverter
False	The line signal is not inverted.
True	The line signal is inverted.
GigEVision: GenICam	LineInverter
Type	Boolean



5.6.5 Line Status

The *Line Status* feature returns the current status of the line selected by [Line Selector](#).

The status of the signal is taken after the signal was possible inverted by [Line Inverter](#).

Line Status is only available if the [Line Mode](#) of the selected line is set to *Input*.

Parameter	Line Status
True	The level of the line signal is High.
False	The level of the line signal is Low.
GigEVision: GenICam	LineStatus
Type	Boolean

5.6.6 Line Status Invalidate

Line Status Invalidate invalidates the value of [Line Status](#), causing it to be re-read from the device.

Parameter	Line Status Invalidate
Execute	Invalidates the value of <i>LineStatus</i> .
GigEVision: GenICam	LineStatusInvalidate
Type	Command

5.6.7 Line Source

Line Source selects which internal I/O source signal is output on the line selected by [Line Selector](#).

The *Line Source* feature is only available if the [Line Mode](#) of the selected line is set to *Output*.

Parameter	Line Source
UserOutput0	The line outputs the User Output Bit 0 state as defined by User Output Value .
UserOutput1	The line outputs the User Output Bit 1 state as defined by User Output Value .
UserOutput2	The line outputs the User Output Bit 2 state as defined by User Output Value .
ExposureActive	Device is doing exposure of a frame.
GigEVision: GenICam	LineSource
Type	Enumeration



5.6.8 Line Format

Line Format indicates the electrical format of the selected line selected by [Line Selector](#).

Parameter	Line Format
TTL	The Line is currently accepting or sending TTL level signals.
OptoCoupled	The Line is opto-coupled.
OpenDrain	The Line is Open Drain.
GigEVision: GenICam	LineFormat
Type	Enumeration

5.6.9 User Output Selector

User Output Selector selects which bit of the user output register will be set by [User Output Value](#).

The bits in the user output register can be selected as source signal in [Line Source](#).

Parameter	User Output Selector
UserOutput0	Selects bit 0 of the user output register.
UserOutput1	Selects bit 1 of the user output register.
UserOutput2	Selects bit 2 of the user output register.
GigEVision: GenICam	UserOutputSelector
Type	Enumeration

5.6.10 User Output Value

The *User Output Value* feature sets the value of the bit selected by [User Output Selector](#).

The bits in the user output register can be selected as source signal in [Line Source](#).

Parameter	User Output Value
False	Set the bit to 0.
True	Set the bit to 1.
GigEVision: GenICam	UserOutputValue
Type	Boolean



5.7 Strobe

The strobe function controls the automatic generation of output pulses on the STROBE_OUT pin which is synchronized to the image sensor's exposure time.

5.7.1 Strobe Enable

The *Strobe Enable* parameter enables the automatic generation of strobe pulses.

Parameter	Strobe Enable
On	Strobe enabled
True	
Off	Strobe disabled
False	
GigE Vision: GenICam	StrobeEnable
Type	Enumeration
VCD Property	VCDID_Strobe\VCDElement_Value

5.7.2 Strobe Polarity

The *Strobe Polarity* parameter can be used to invert the strobe pulse output.

Parameter	Strobe Polarity
ActiveHigh	The STROBE_OUT pin is logically high during the exposure time
True	
ActiveLow	The STROBE_OUT pin is logically low during the exposure time
False	
GigE Vision: GenICam	StrobePolarity
Type	Enumeration
VCD Property	VCDID_Strobe\VCDElement_StrobePolarity

5.7.3 Strobe Operation

The *Strobe Operation* parameter specifies how the length of the strobe pulses are controlled.



Parameter	Strobe Operation
Exposure	Output pulse duration is equal to the current exposure time
True	
GigEVision: GenICam	StrobeOperation
Type	Enumeration
VCD Property	VCDID_Strobe\VCDElement_StrobeMode

5.8 White Balance

The ViC 43GX676 color camera can perform white balance by digital multiplication of the appropriate raw pixel values.

5.8.1 Auto White Balance

ViC 43GX676 can perform *Auto White Balance*. It can be enabled continuously when changes in lighting conditions are expected. Under controlled lighting conditions, however, one-time white balance calibration is the recommended approach.

To perform one-time white balance calibration, place a reference white sheet in front of the camera and set `BalanceWhiteAuto` to *Once*. The camera will then find the correct white balance settings for the current light conditions and keep them active until instructed otherwise.

Parameter	Auto White Balance
Continuous	Enable automatic white balance
True	
Once	Enable automatic white balance until the color channels have been balanced once
One Push	
Off	Disable automatic white balance
False	
GigEVision: GenICam	BalanceWhiteAuto
Type	Enumeration
VCD Property	VCDID_WhiteBalance\VCDElement_Auto VCDID_WhiteBalance\VCDElement_OnePush

5.8.2 White Balance Mode

The default auto white balance algorithm is *Gray World*. It is selected by setting the *White Balance Mode* accordingly. The *Gray World* algorithm operates under the assumption that the average color of a scene is near gray and adjusts the white balance coefficients so the average color of the resulting image is gray as well. In the case where this assumption is



wrong (e.g. the camera is pointing at a blue carpet), the auto white balance algorithm will select coefficients that do not result in a visually accurate image.

To avoid the problems posed by the *Gray World* algorithm, the *Temperature* mode can be used. This mode operates by trying to determine the color temperature of the light source.

Parameter	White Balance Mode
Gray World	Use the <i>Gray World</i> model
Temperature	Use the <i>Temperature</i> model
GigEVision: GenICam	BalanceWhiteMode
Type	Enumeration
VCD Property	VCDID_WhiteBalance \VCDElement_WhiteBalanceMode

To assist the automatic white balance temperature detection, *White Balance Auto Preset* can be used to limit the range of valid color temperatures.

Parameter	White Balance Auto Preset
Any	Allow any color temperature
Auto Warm White	Limit color temperature to approximately 2500-4000 K
Auto Cool White	Limit color temperature to approximately 4000-5800 K
Auto Daylight	Limit color temperature to approximately 5700-7500 K
Auto Deep Shade	Limit color temperature to approximately 7500-10000 K
GigEVision: GenICam	BalanceWhiteAutoPreset
Type	Enumeration
VCD Property	VCDID_WhiteBalance \VCDElement_WhiteBalanceAutoPreset

5.8.3 Manual White Balance

If *Auto White Balance* is not enabled, the amplifiers for the red, green and blue channels can be controlled manually.



Parameter	White Balance Red
Minimum	0
Maximum	3.984375
Default	auto
GigEVision: GenICam	BalanceRatio[BalanceRatioSelector=Red]
Type	Float
VCD Property	VCDID_WhiteBalance \VCDElement_WhiteBalanceRed

Parameter	White Balance Green
Minimum	0
Maximum	3.984375
Default	auto
GigEVision: GenICam	BalanceRatio[BalanceRatioSelector=Green]
Type	Float
VCD Property	VCDID_WhiteBalance \VCDElement_WhiteBalanceGreen

Parameter	White Balance Blue
Minimum	0
Maximum	3.984375
Default	auto
GigEVision: GenICam	BalanceRatio[BalanceRatioSelector=Blue]
VCD Property	VCDID_WhiteBalance \VCDElement_WhiteBalanceBlue

If *White Balance Mode* is set to *Temperature*, the color temperature can be set directly. Additionally, a light source can be selected from a list of presets.



Parameter	White Balance Temperature
Minimum	2500 K
Maximum	10000 K
Default	auto
Increment	100
GigEVision: GenICam	BalanceWhiteTemperature
Type	Integer
VCD Property	VCDID_WhiteBalance \VCDElement_WhiteBalanceTemperature

Parameter	White Balance Temperature Preset
Sodium-Vapor Lamp	2500 K
Warm Light	2700 K
Halogen Light	3000 K
Neutral White	3500 K
Cool White Fluorescent Light	4000 K
Cool White/Daylight (CFL)	5000 K
Daylight	6000 K
Cool White LED	7500 K
Blue Sky	10000 K
GigEVision: GenICam	BalanceWhiteTemperaturePreset
Type	Enumeration
VCD Property	VCDID_WhiteBalance \VCDElement_TemperaturePreset

5.9 Image Processing

5.9.1 Gamma

Visus series cameras can perform gamma correction on the image data. If the pixel format of a color camera is set a YUV mode, gamma correction is applied to the Y channel. In bayer raw and RGB24 modes, all color channels are subject to the same gamma correction.



Parameter	Gamma
Minimum	0.3
Maximum	1.2
Default	0.55
GigEVision: GenICam	Gamma
Type	Float
VCD Property	VCDID_Gamma\VCDElement_Value

5.9.2 Lookup Table

The Visus series allows the user to specify a lookup table (LUT) that can transform pixel values. This lookup table can be used to perform tasks like histogram equalization inside the camera.

If the pixel format of a color camera is set to one of the YUV modes, the lookup table is applied only to the Y channel. In bayer raw and RGB24 modes, all color channels are subject to the same lookup operation.

The lookup table has 257 16-bit entries. The upper 8 bits of the image data are used to select the appropriate entry in the lookup table, while the remaining bits are used to interpolate between the selected entry and one of its neighbors.

The *LUT Enable* feature enables the lookup table.

Parameter	LUT Enable
True	Enable lookup table operation
False	Disable lookup table operation
GigEVision: GenICam	LUTEnable
Type	Boolean

The lookup table values can be programmed using the *LUT Index* and *LUT Value* features.

Parameter	LUT Index
Minimum	0
Maximum	256
GigEVision: GenICam	LUTIndex
Type	Integer



Parameter	LUT Value
Minimum	0
Maximum	65535
GigEVision: GenICam	LUTValue
Type	Integer

The whole lookup table can be quickly reprogrammed through the *LUT Value All* feature.

Parameter	LUT Value All
Value	1028 bytes of memory containing 257 LUT entries. Each 16-bit LUT entry is aligned on a 32-bit boundary
GigEVision: GenICam	LUTValueAll
Type	Register

Important: Since gamma correction is implemented using the same hardware as the lookup table, gamma correction is disabled when the lookup table is enabled.

5.10 Color Processing

The ViC 43GX676 color camera allows color adjustments with the *Hue* and *Saturation* parameters. These adjustments work with all output pixel formats.

Important: When a bayer raw pixel format is selected, *Hue* and *Saturation* still work. However, when at least one of them is enabled (set to non-default value), the resulting image is slightly blurred because of the way these parameters are implemented internally.

5.10.1 Hue

The *Hue* parameter controls the color angle of the output image.

Parameter	Hue
Minimum	-180
Maximum	180
Default	0
GigEVision: GenICam	Hue
Type	Float
VCD Property	VCDID_Hue\VCDElement_Value



5.10.2 Saturation

The *Saturation* parameter controls the color saturation of the output image.

Parameter	Saturation
Minimum	0
Maximum	255
Default	64
GigEVision: GenICam	Saturation
Type	Float
VCD Property	VCDID_Saturation\VCDElement_Value

5.10.3 Color Correction Matrix

As seen in the [Spectral Characteristics](#) diagram, the frequencies at which the red, green and blue pixels respond to incoming light overlap. This causes the colors of objects in captured images to differ from the colors of the same objects seen in reality.

A RGB to RGB color correction matrix can be used to change the pixel data output of the camera so that the colors in captured image are a closer match to what is expected by human observers.

Parameter	Enable Color Correction Matrix
True	Enable Color Correction Matrix
False	Disable Color Correction Matrix
GigEVision: GenICam	ColorTransformationEnable
Type	Boolean
VCD Property	VCDID_ColorMatrix\VCDElement_Value

By default, the values of the color matrix coefficients are initialized with values optimized for skin tones and other everyday objects.

If necessary, the matrix coefficients can be controlled manually.

When using *GenICam*, select a coefficient using `ColorTransformationValueSelector` and then change it via the `ColorTransformationValue`.

When using *IC Imaging Control*, the matrix coefficients are controlled via the `VCDElement_ColorMatrix[RGB][RGB]` elements of `VCDID_ColorMatrix`.



Parameter	Red contribution to the red pixel
Minimum	-3.9375
Maximum	3.9375
GigEVision: GenICam	ColorTransformationValue [ColorTransformationValueSelector=Gain00]
Type	Float
VCD Property	VCDID_ColorMatrix \VCDElement_ColorMatrixRR

Parameter	Green contribution to the red pixel
Minimum	-3.9375
Maximum	3.9375
GigEVision: GenICam	ColorTransformationValue [ColorTransformationValueSelector=Gain01]
Type	Float
VCD Property	VCDID_ColorMatrix \VCDElement_ColorMatrixRG

Parameter	Blue contribution to the red pixel
Minimum	-3.9375
Maximum	3.9375
GigEVision: GenICam	ColorTransformationValue [ColorTransformationValueSelector=Gain02]
Type	Float
VCD Property	VCDID_ColorMatrix \VCDElement_ColorMatrixRB

Parameter	Red contribution to the green pixel
Minimum	-3.9375
Maximum	3.9375
GigEVision: GenICam	ColorTransformationValue [ColorTransformationValueSelector=Gain10]
Type	Float
VCD Property	VCDID_ColorMatrix \VCDElement_ColorMatrixGR



Parameter	Green contribution to the green pixel
Minimum	-3.9375
Maximum	3.9375
GigE Vision: GenICam	ColorTransformationValue [ColorTransformationValueSelector=Gain11]
Type	Float
VCD Property	VCDID_ColorMatrix \VCDElement_ColorMatrixGG

Parameter	Blue contribution to the green pixel
Minimum	-3.9375
Maximum	3.9375
GigE Vision: GenICam	ColorTransformationValue [ColorTransformationValueSelector=Gain12]
Type	Float
VCD Property	VCDID_ColorMatrix \VCDElement_ColorMatrixGB

Parameter	Red contribution to the blue pixel
Minimum	-3.9375
Maximum	3.9375
GigE Vision: GenICam	ColorTransformationValue [ColorTransformationValueSelector=Gain20]
Type	Float
VCD Property	VCDID_ColorMatrix \VCDElement_ColorMatrixBR

Parameter	Green contribution to the blue pixel
Minimum	-3.9375
Maximum	3.9375
GigE Vision: GenICam	ColorTransformationValue [ColorTransformationValueSelector=Gain21]
Type	Float
VCD Property	VCDID_ColorMatrix \VCDElement_ColorMatrixBG



Parameter	Blue contribution to the blue pixel
Minimum	-3.9375
Maximum	3.9375
GigE Vision: GenICam	ColorTransformationValue [ColorTransformationValueSelector=Gain22]
Type	Float
VCD Property	VCDID_ColorMatrix \VCDElement_ColorMatrixBB

5.11 Region of Interest for Auto Functions

Visus series cameras allow for the setting of a region of interest that is used while controlling the [Auto Exposure](#), [Auto Gain](#) and [Auto White Balance](#) functions.

5.11.1 Auto Functions ROI Enable

The *Auto Functions ROI Enable* parameter allows for the use of a region of interest for auto functions.

Parameter	Auto Functions ROI Enable
True	Auto functions only take a specified part of the image into account
False	Auto functions look at the whole image
GigE Vision: GenICam	AutoFunctionsROIEnable
Type	Boolean
VCD Property	VCDID_AutoRoi\VCDElement_Value

5.11.2 Auto Functions ROI Preset

The *Auto Functions ROI Preset* parameter lets the user select from a list of ROI presets.



Parameter	Auto Functions ROI Preset
Full Sensor	Select the full output image
Center 50%	Select a rectangular area in the center of the output image
Center 25%	Select a small rectangular area in the center of the output image
Bottom Half	Select the bottom half of the output image
Top Half	Select the top half of the output image
Custom Rectangle	Select a custom rectangle for fine-grained control
GigEVision: GenICam	AutoFunctionsROI_Preset
Type	Enumeration
VCD Property	VCDID_AutoRoi\VCDElement_AutoRoiPreset

5.11.3 Auto Functions ROI Custom Rectangle

When *Auto Functions ROI Preset* is set to *Custom Rectangle*, the user can manually set the position and size of the region of interest. The coordinates are relative to the origin of the current video format as specified by [Partial Scan Offset](#).

Parameter	Auto Functions ROI Left
Minimum	0
Maximum	3520
Increment	2
GigEVision: GenICam	AutoFunctionsROI_Left
Type	Integer
VCD Property	VCDID_AutoRoi \VCDElement_AutoRoiLeftRelative

Parameter	Auto Functions ROI Top
Minimum	0
Maximum	3520
Increment	2
GigEVision: GenICam	AutoFunctionsROI_Top
Type	Integer
VCD Property	VCDID_AutoRoi \VCDElement_AutoRoiTopRelative



Parameter	Auto Functions ROI Width
Minimum	16
Maximum	3536
Increment	2
GigEVision: GenICam	AutoFunctionsROIWidth
Type	Integer
VCD Property	VCDID_AutoRoi \VCDElement_AutoRoiWidthRelative

Parameter	Auto Functions ROI Height
Minimum	16
Maximum	3536
Increment	2
GigEVision: GenICam	AutoFunctionsROIHeight
Type	Integer
VCD Property	VCDID_AutoRoi \VCDElement_AutoRoiHeightRelative

5.12 User Sets

Visus series cameras can store their complete configuration into built-in non-volatile memory. The camera configuration can be saved into and restored from one of two available memory slots upon user's request. Additionally, the camera can be configured to load one of the user's camera configurations at startup.

5.12.1 User Set Selector

The *User Set Selector* parameter selects the memory slot on which consecutive load and save commands are executed.

Parameter	User Set Selector
UserSet1	First of the two memory slots for user configurations
UserSet2	Second of the two memory slots for user configurations
Default	A special memory slot that always contains the camera's factory default configuration. It cannot be overwritten
GigEVision: GenICam	UserSetSelector
Type	Enumeration



5.12.2 Load User Set

By using the *Load User Set* command, the user can restore the camera configuration from the memory slot selected by *User Set Selector*.

Parameter	Load User Set
Execute	Restore the camera configuration from the memory slot specified by <i>User Set Selector</i>
GigEVision: GenICam	UserSetLoad
Type	Command

5.12.3 Save User Set

By using the *Save User Set* command, the user can save the camera configuration into the memory slot selected by *User Set Selector*.

Parameter	Save User Set
Execute	Save the current camera configuration into the memory slot specified by <i>User Set Selector</i>
GigEVision: GenICam	UserSetSave
Type	Command

5.12.4 Default User Set

The *Default User Set* parameter controls the camera's startup behavior. It selects which memory slot is used for device initialization when the camera is powered up.

Parameter	Default User Set
UserSet1	Load configuration from the first memory slot
UserSet2	Load configuration from the second memory slot
Default	Load factory default configuration
GigEVision: GenICam	UserSetDefault
Type	Enumeration

5.13 Timestamp Control

Visus series cameras run an internal timestamp clock. The clock starts at zero when the camera is powered up.

The source of the timestamp clock has a frequency tolerance of ± 20 ppm.

All image buffers sent by the camera have a timestamp attached to them.



Notification for asynchronous [Events](#) also contain a timestamp value.

The time stamp can be synchronized to other network devices via [Precision Time Protocol](#).

5.13.1 Timestamp Latch

The *Timestamp Latch* command copies the current value of the camera's timestamp counter into the [Timestamp Latch Value](#) so that it can be read later.

Parameter	Timestamp Latch
Execute	Copies the current value of the camera's timestamp into Timestamp Latch Value .
GigE Vision: GenICam	TimestampLatch
Type	Command

5.13.2 Timestamp Latch Value

The *Timestamp Latch Value* feature contains the value of camera's timestamp counter at the time of the previous execution of the [Timestamp Latch](#) command.

A human-readable interpretation of the value can be read from [Timestamp Latch String](#).

Parameter	Timestamp Latch Value
GigE Vision: GenICam	TimestampLatchValue
Type	Integer
Unit	µs

5.13.3 Timestamp Latch String

The *Timestamp Latch String* feature contains a human-readable interpretation of the value of [Timestamp Latch Value](#).

Parameter	Timestamp Latch String
GigE Vision: GenICam	TimestampLatchString
Type	String

5.13.4 Timestamp Reset

The *Timestamp Reset* command resets the camera's timestamp counter to start from zero.



Parameter	Timestamp Reset
Execute	Resets the camera's timestamp counter.
GigEVision: GenICam	TimestampReset
Type	Command

Important: Resetting the timestamp counter is not possible if [PTP Enable](#) is enabled.

5.14 Precision Time Protocol

All Visus series cameras can synchronize its internal clock to other devices via *Precision Time Protocol* (PTP, IEEE 1588).

When multiple PTP devices are connected through the same network, they will synchronize their clocks. This allows the image timestamps to remain comparable between cameras.

A camera running with PTP enabled can also schedule actions to be executed at a specified time point in the future through *Scheduled Actions*.

PTP is enabled by default.

5.14.1 PTP Enable

The *PTP Enable* parameter enables or disables the camera's usage of the *Precision Time Protocol*.

Parameter	PTP Enable
True	Use Precision Time Protocol
False	PTP disabled
GigEVision: GenICam	PtpEnable
Type	Boolean

5.14.2 PTP Status

PTP Status is a read-only feature that reports the current status of the *Precision Time Protocol* algorithm.



Parameter	PTP Status
Master	The camera acts as PTP master clock.
Slave	The camera synchronizes its time stamp to a PTP master clock.
Uncalibrated	PTP was recently enabled, or a recent change in the network configuration initiated a resynchronization.
Disabled	PTP is disabled.
GigEVision: GenICam	PtpStatus
Type	Enumeration

5.15 Action Scheduler

When *Precision Time Protocol* is enabled, the action scheduler can be used to plan and run actions at some point in the future.

The only action the camera can perform right now is triggering images.

Action triggers are only accepted when [Trigger Source](#) is set to `Action0` or `Any`.

5.15.1 Action Selector

The *Action Selector* feature selects the action that the [Action Scheduler Time](#), [Action Scheduler Interval](#), [Action Scheduler Commit](#) and [Action Scheduler Cancel](#) features act on.

Parameter	Action Selector
0	<code>Action0</code> , which is hard-wired to trigger images
GigEVision: GenICam	<code>ActionSelector</code>
Type	Enumeration

5.15.2 Action Scheduler Time

The *Action Scheduler Time* is the time for when an action is scheduled, specified as a PTP timestamp in nanosecond units.

Scheduling the action to a time in the past will cause the action to be performed immediately.

Scheduling a repeated action to start in the past will ignore missed actions and continue as if it had been scheduled earlier.

Parameter	Action Scheduler Time
GigEVision: GenICam	<code>ActionSchedulerTime</code>
Type	Integer



5.15.3 Action Scheduler Interval

The *Action Scheduler Interval* feature allows instructing the action scheduler to repeat the scheduled action in a fixed interval, indefinitely.

If the interval is set to 0, the action is performed once and not repeated.

The interval is specified in microseconds.

Parameter	Action Scheduler Interval
Minimum	0
Maximum	4294967295 us
GigEVision: GenICam	ActionSchedulerInterval
Type	Integer

5.15.4 Action Scheduler Commit

Executing the *Action Scheduler Commit* command commits an action to the queue of scheduled actions.

The action is planned to be performed at the time specified by [Action Scheduler Time](#).

If [Action Scheduler Interval](#) has a value other than 0, the action will be repeated with the specified interval indefinitely, or until the [Action Scheduler Cancel](#) command is executed.

There is a finite number of queue slots available, trying to queue too many actions will fail. The maximum length of the queue is reported by the `ActionQueueSize` feature.

Parameter	Action Scheduler Commit
Execute	Schedule the action specified by Action Selector to be performed at a specified time in the future.
GigEVision: GenICam	ActionSchedulerCommit
Type	Command

5.15.5 Action Scheduler Cancel

Executing the *Action Scheduler Cancel* command cancels all scheduled actions of the action type selected by [Action Selector](#).



Parameter	Action Scheduler Cancel
Execute	Cancel all scheduled actions of the type specified by Action Selector.
GigEVision: GenICam	ActionSchedulerCancel
Type	Command

5.16 Events

Visus series devices can send asynchronous event packets, notifying the application about certain events during device operation.

To enable a specific event, select the event to enable in [Event Selector](#) and then set [Event Notification](#) to *On*.

The way to receive the event notifications depends on the used camera SDK. In most cases, a notification handler has to be registered on the feature named after the event, e.g. *EventTest* or *EventExposureEnd*. Additional event data can often be queried via additional features with a derived name, e.g. *EventTestTimestamp* or *EventExposureEndFrameID*.

5.16.1 Event Selector

The *Event Selector* parameter selects an event to configure.

Parameter	Event Selector
FrameTriggerMissed	Selects the FrameTriggerMissed event
Line1FallingEdge	Selects the Line1FallingEdge event
Line1RisingEdge	Selects the Line1RisingEdge event
Test	Selects the Test event
GigEVision: GenICam	EventSelector
Type	Enumeration

5.16.2 Event Notification

The *Event Notification* parameter enables or disables the event selected by [Event Selector](#).

Parameter	Event Notification
On	Enables notifications for the selected event
Off	Disables notifications for the selected event
GigEVision: GenICam	EventNotification
Type	Enumeration



5.16.3 Event Frame Trigger Missed

The *Event Frame Trigger Missed* feature is notified when the camera receives a trigger pulse, but the sensor was not in a state where a new exposure could be started.

The value of this feature has no meaning and should not be read.

Parameter	Event Frame Trigger Missed
GigEVision: GenICam	EventFrameTriggerMissed
Type	Integer

The *Event Frame Trigger Missed Timestamp* parameter identifies the point in time when the current frame trigger missed event occurred.

Please refer to the documentation of your camera SDK on how to safely read the timestamp associated with the current event when a notification is received.

Parameter	Event Frame Trigger Missed Timestamp
GigEVision: GenICam	EventFrameTriggerMissedTimestamp
Type	Integer

5.16.4 Event Line1 Falling Edge

The *Event Line1 Falling Edge* feature is notified when the input on Line1 changes from high to low.

The value of this feature has no meaning and should not be read.

Parameter	Event Line1 Falling Edge
GigEVision: GenICam	EventLine1FallingEdge
Type	Integer

The *Event Line1 Falling Edge Timestamp* parameter identifies the point in time when the current line1 falling edge event occurred.

Please refer to the documentation of your camera SDK on how to safely read the timestamp associated with the current event when a notification is received.

Parameter	Event Line1 Falling Edge Timestamp
GigEVision: GenICam	EventLine1FallingEdgeTimestamp
Type	Integer



5.16.5 Event Line1 Rising Edge

The *Event Line1 Rising Edge* feature is notified when the input on Line1 changes from high to low.

The value of this feature has no meaning and should not be read.

Parameter	Event Line1 Rising Edge
GigEVision: GenICam	EventLine1RisingEdge
Type	Integer

The *Event Line1 Rising Edge Timestamp* parameter identifies the point in time when the current line1 rising edge event occurred.

Please refer to the documentation of your camera SDK on how to safely read the timestamp associated with the current event when a notification is received.

Parameter	Event Line1 Rising Edge Timestamp
GigEVision: GenICam	EventLine1RisingEdgeTimestamp
Type	Integer

5.16.6 Event Test

The *Event Test* feature is notified when a test event occurs.

To generate a test event, use the *Test Event Generate* command.

The value of this feature has no meaning and should not be read.

Parameter	Event Test
GigEVision: GenICam	EventTest
Type	Integer

The *Event Test Timestamp* parameter identifies the point in time when the current test event occurred.

Please refer to the documentation of your camera SDK on how to safely read the timestamp associated with the current event when a notification is received.

Parameter	Event Test Timestamp
GigEVision: GenICam	EventTestTimestamp
Type	Integer

The *Test Event Generate* command can be used to generate a test event.



Parameter	Test Event Generate
Execute	Generate one test event
GigEVision: GenICam	TestEventGenerate
Type	Command

5.17 Bandwidth Control

When using multiple Visus series devices connected to the same network adapter, the data rate has to be considered to allow consistent operation.

To limit the bandwidth of a camera, set [Device Link Throughput Limit Mode](#) to `On`, and set [Device Link Throughput Limit](#) to the desired maximum data rate.

5.17.1 Device Link Throughput Limit Mode

The *Device Link Throughput Limit Mode* parameter enables or disables the effect of [Device Link Throughput Limit](#).

If set, the camera's internal frame rate is automatically reduced to fit into the available bandwidth.

An inter-packet delay is added between streaming packets to ensure the network bandwidth does not exceed the limit.

Parameter	Device Link Throughput Limit Mode
Off	The bandwidth the device uses for streaming is unlimited.
On	The maximum bandwidth the device uses for streaming is defined by Device Link Throughput Limit .
GigEVision: GenICam	DeviceLinkThroughputLimitMode
Type	Enumeration

5.17.2 Device Link Throughput Limit

The *Device Link Throughput Limit* parameter defines the maximum bandwidth used by the device to stream data.

[Device Link Throughput Limit Mode](#) must be set to `On` for *Device Link Throughput Limit* to have an effect.



Parameter	Device Link Throughput Limit
Minimum	1000000 Bps
Maximum	125000000 Bps
GigEVision: GenICam	DeviceLinkThroughputLimit
Type	Integer



6 Status LEDs

6.1 LEDs on the RJ45 Connector

The LEDs on the RJ45 connector show the network connection status and network activity.

LED	Description
Green	On when connected to Gigabit Ethernet
Orange	Network activity indicator



7 Revision History

Date	Version	Description
2025/7/24		Initial Release of this document



ViC 43GX676 Technical Reference Manual

All product and company names in this document may be trademarks and tradenames of their respective owners and are hereby acknowledged.

The Imaging Source Europe GmbH cannot and does not take any responsibility or liability for any information contained in this document. The source code presented in this document is exclusively used for didactic purposes. The Imaging Source does not assume any kind of warranty expressed or implied, resulting from the use of the content of this document or the source code.

The Imaging Source Company reserves the right to make changes in specifications, function or design at any time and without prior notice.

Last update: November 2025

© 2025 The Imaging Source

All rights reserved. Reprint, also in parts, only allowed with permission of The Imaging Source Europe GmbH.

All weights and dimensions are approximate. Unless otherwise specified, the lenses shown in the context of cameras are not shipped with these cameras.

Headquarters:

*The Imaging Source Europe GmbH
Überseetor 18, D-28217 Bremen, Germany
Phone: +49 421 33591-0*

North & South America:

*The Imaging Source, LLC
4600 Park Road, Suite 470, Charlotte, NC 28209, United States
Phone: +1 877-462-4772*

Asia Pacific:

*The Imaging Source Asia Co., Ltd.
3F., No. 43-7/8, Zhongxing Road
Xizhi District, New Taipei City 221012, Taiwan
Phone: +886 2-2792-3153*

www.theimagingsource.com