

Optronis CoaXPress Cameras  
CamPerform CP70 Series

# User Manual

## CP70-12-M/C-188



**CoaXPress**

**Document Reference** 1874-SU-01-L  
**Release Date** 17/08/2018

## About this manual

Thank you for using an Optronis product.

The purpose of this document is to provide a description of Optronis CP70-12-M/C-188 camera.

Please read this manual thoroughly before operating your new camera for the first time. Please follow all instructions and observe warnings.

This document is subject to change without notice and corresponds to the last camera firmware version.

You can check product page download area to be sure you are using:

- Last Datasheet version
- Last Manual version
- Last Firmware version
- Last Firmware Update software version
- Last CAD data version

<http://optronis.com/en/products/camperform-cp70-12-mc-188/>

## Support

We hope that this manual can answer your questions, but should you have any further questions or if you wish to claim a service or warranty case, please contact your local dealer or refer to the Optronis support. You can contact our support by using our website or by email at the following address: [support@optronis.com](mailto:support@optronis.com). To process your request efficiently please prepare following information:

- Camera Model name: CPX0-XX-M/C-XX. (See label at the bottom side of the camera).
- Serial-Number: 1xxx-ST-XXX. (See label at the bottom side of the camera).
- Frame Grabber Model
- Cable type (BNC or Din 1.0/2.3, adapter types...)
- Operating System (Windows 7/10/32bit/64bit ...)
- Short description of the problem

## Contacts

To contact us, please use the information below.

Address	OPTRONIS GMBH Ludwigstr. 2 D-77694 Kehl Germany Tel.: +49 (0) 78 51/91 26-0 / Fax: +49 (0) 78 51/91 26-10
Website	<a href="http://optronis.com/en/">http://optronis.com/en/</a>
Contact Form	<a href="http://optronis.com/en/kontakt/">http://optronis.com/en/kontakt/</a>
General Inquiries	<a href="mailto:info@optronis.com">info@optronis.com</a>
Sales	<a href="mailto:sales@optronis.com">sales@optronis.com</a>
Support	<a href="mailto:support@optronis.com">support@optronis.com</a>

# Table of Contents

1	General.....	6
1.1	Declaration of Conformity.....	6
1.2	RoHS Compliance .....	7
1.3	Standards .....	7
1.4	Remarks.....	7
1.5	Scope of Delivery.....	7
2	Getting Started.....	8
2.1	General Precautions.....	8
2.1.1	Environmental Conditions .....	8
2.1.2	Camera Handling.....	8
2.2	Setting Up System .....	9
2.2.1	Typical System Configuration .....	9
2.2.2	Set Up Lenses.....	9
2.2.3	Optical Considerations.....	10
3	Camera Overview .....	11
3.1	Model Description.....	11
3.1.1	Model Name and Options.....	11
3.2	Technical Data.....	12
3.2.1	General Info .....	12
3.2.2	Spectral Response.....	13
3.2.3	Glass Filter.....	13
3.2.4	Mechanical Drawings - Dimensions and Mounting Points .....	14
4	Camera Main Features .....	15
4.1	Frame Format.....	15
4.1.1	Supported Pixel Formats.....	15
4.1.2	Single ROI.....	15
4.1.3	Dual ROI .....	16
4.2	Available CXP Configurations .....	18
4.3	Acquisition Control - Frame Generation and Synchronization .....	18
4.4	TriggerActivation .....	19
4.5	Frame Rate and Exposure .....	19
4.5.1	Synchronization timings.....	20
4.5.2	Max & Min FPS.....	21
4.5.3	Max & Min Exposure Time.....	21

4.6	Sync Out Output.....	21
4.7	Image Enhancement .....	22
4.7.1	Hot Pixels Correction .....	22
4.7.2	Gain.....	22
4.8	Counter Information .....	22
4.9	Multi Slope (HDR) mode.....	22
4.9.1	Multi Slope Parameters .....	22
4.9.2	Multi Slope Principle .....	23
4.9.3	Multi-Slope Example.....	23
4.10	Save User Configuration to Flash .....	24
5	Camera Hardware Interface.....	25
5.1	Connectors and LED .....	25
5.1.1	Identify Connectors and LED Positions .....	25
5.1.2	Powering Camera.....	25
5.1.3	CoaXPRESS Connectors .....	26
5.1.4	Auxiliary Connector.....	27
5.1.5	CoaXPRESS Status LEDs .....	29
6	Camera Control Interface.....	30
6.1	GenICam XML Interface .....	30
6.1.1	CoaXPRESS GenICam Compliant Interface.....	30
6.1.2	XML Entry Access Mode.....	30
6.1.3	XML Entry Types Description .....	30
6.1.4	XML Entry Allowed Values.....	30
6.1.5	XML Masked Values.....	31
6.1.6	Acquisition/Live Stop Required.....	31
6.2	XML Main Entries - Features Description.....	32
7	Firmware Update .....	36
8	Revisions.....	37
8.1	Manual Revision .....	37
8.2	Firmware Revision.....	37

# Table of Figures

Figure 1: Typical System .....	9
Figure 2: Field of View .....	10
Figure 3: Camera Model Name Decoder .....	11
Figure 4: Camera Serial Number Decoder .....	11
Figure 5: Camera Spectral Response .....	13
Figure 6: Glass Filter typical transmittance (1830-SS-10 IR Filter).....	13
Figure 7: CP70 Dimensions (with F-Mount option) .....	14
Figure 8: Camera Single ROI control .....	16
Figure 9: Camera Dual ROI control .....	16
Figure 10: Camera output image when using dual ROI .....	17
Figure 11: Sync Timings .....	20
Figure 12: Multi-Slope control .....	23
Figure 13: CP70 HW Identification.....	25
Figure 14: CP70 Power Connector .....	26
Figure 15: CP70 Auxiliary Connector .....	27
Figure 16: Sync In Input Schematics .....	28
Figure 17: Sync Out Output Schematics .....	28
Figure 18: Camera Series Selection .....	36
Figure 19: Software Interface .....	36

# 1 General

---

## 1.1 Declaration of Conformity



### **Declaration of Conformity**

**In accordance with the EU directive 2014/30/EU (electromagnetical compatibility) of 26. February 2014**

Hereby we explain that those corresponds to below designated products in its conception and design as well as in circulation the execution the fundamental safety and health requirements of the Community directive 2014/30/EU brought by us. In the case of a change of the product not co-ordinated with us this explanation loses its validity.

**Manufacturer:** Optronis GmbH  
Ludwigstr. 2  
D-77694 Kehl

**Authorized person** Dr. Patrick Summ  
(Managing Director)

**Description of the electrical equipment:**

function: Machine Vision Kamera  
type / modell: CP70-12-M-188  
serial number: 1874-ST-017

**The agreement with further valid guidelines / regulations following for the product is explained:**

EMV Directive (2014/30/EU) of 26. February 2014

**Reference to the harmonized standards:**

DIN EN 61326-1:2006-10  
Electrical equipment for measurement, control and laboratory use  
– EMC requirements -  
Part 1: General requirements

**Date:** 27. December 2016

**Personal data of the signer:** Dr. Patrick Summ

**Signature:**

## 1.2 RoHS Compliance



CamPerform CP70-12-M/C-188 cameras are Pb free manufactured.

## 1.3 Standards

The camera has been developed according to following standards:

- CoaXPress Standard Version 1.1.1 - JIA CXP-001-2015
- GenICam SFNC 2.3
- GenICam PFNC 2.1

## 1.4 Remarks

The following signs are used in this user manual to highlight some information:



Remarks and additional information.



Attention, warnings.

## 1.5 Scope of Delivery

The camera is delivered together with:

- Brief Introduction

Available accessories are:

- Lens mount:
  - C-Mount lens adapter
  - F-Mount lens adapter
  - G-Mount lens adapter
  - M42x1 lens adapter
  - M42x0.75 lens adapter
  - Custom mounts on request
- Pigtail cable CP70, CP90
- Power supply CP70, CP90
- Programming cable CP70, CP90

## 2 Getting Started

---

### 2.1 General Precautions

#### 2.1.1 Environmental Conditions

Recommended environmental conditions are:

Temperature range during operation: < + 40°C / ~ + 104°F (ambient temperature)  
> 0°C / ~ + 32°F (ambient temperature)

Humidity: < 80%



Optronis does not guaranty camera operation beyond above conditions and camera lifetime might be reduced.

#### 2.1.2 Camera Handling

Please be careful when using camera. Pay attention especially to:

Camera power	Please be careful when powering camera. Use power over Coaxpress (PoCXP) or delivered external power supply (option).
Temperature and Humidity	Please respect recommended conditions. You may use controlled airflow or heatsinks to keep camera in better temperature conditions.
Direct sun light	Please avoid direct-sun light, camera sensor may be damaged.
Dust and Cleaning	The camera is produced in a dust-controlled environment. Please be careful when changing lens, mount or accessing any part close to the sensor. Always unplug the camera before cleaning it. Do not use cleaning liquids or sprays. Instead, use a dry and soft duster.



Do not open the housing of the camera.  
Warranty becomes void if the camera housing is opened.



## 2.2 Setting Up System

### 2.2.1 Typical System Configuration

A typical system with Optronis CoaXPress camera is composed of:

- An Optronis CoaXPress camera
- CoaXPress cables
- An acquisition and control system (a CoaXPress Frame Grabber in a PC)
- A Control Software based on Frame Grabber features
- Optional features (External power supply, External synchronization system, etc...).

Here is an illustration of such a system:

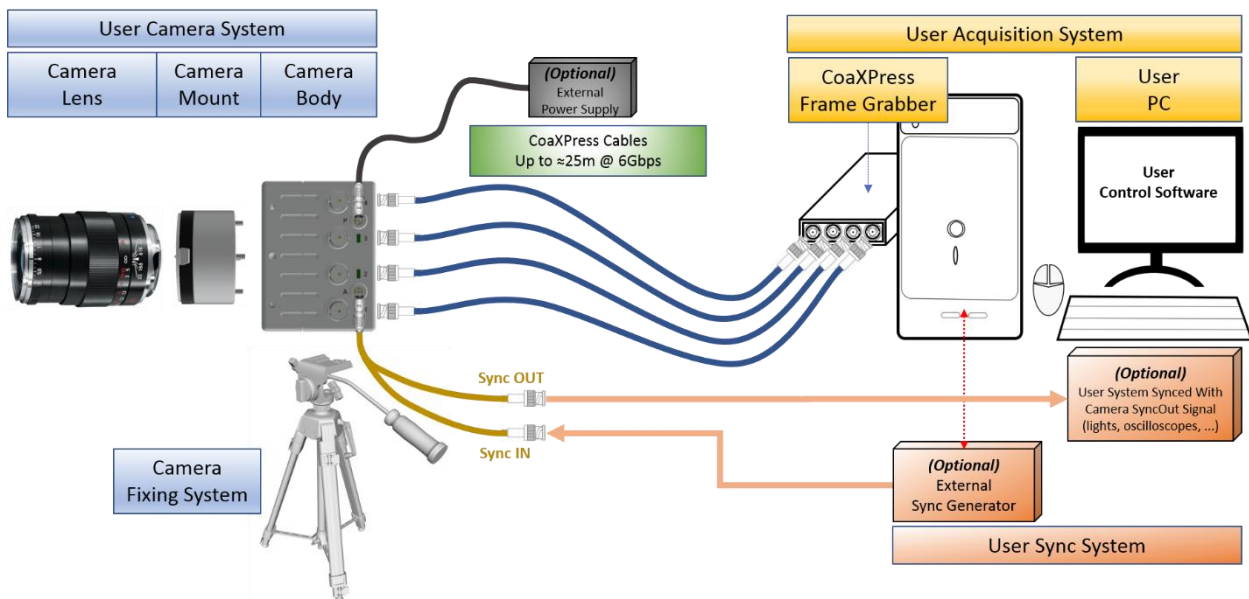

Figure 1: Typical System

### 2.2.2 Set Up Lenses

Please be careful when installing or removing camera lens. Depending on your lens mount type and lens, pay attention to following points:

- If your lens has a mounting mark, first align lens-holder and lens mounting marks and then rotate anti-clockwise to lock the lens. To remove the lens, unlock the lens-holder silver clip and rotate clockwise until marks are aligned. Then remove the lens.
- If your lens has a screw thread, rotate anti-clockwise to remove it and clockwise to installing it.
- If you are removing the lens from the camera, always use a cap on the camera to avoid dust infiltration. Use also caps on both lens sides for the same reason.
- Do not forget to remove the cap of your lens before using the camera.

## 2.2.3 Optical Considerations

A typical optical system can be represented as below.

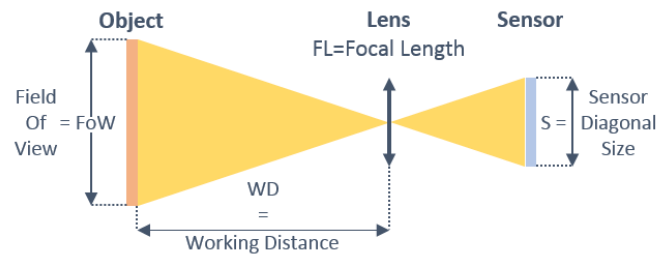

**Figure 2: Field of View**

Using above notations:

The sensor size depends on frame dimension:

$$\text{Sensor Diagonal Size} = S = \text{PixelSize} \times \sqrt{\text{Resolution}_X^2 + \text{Resolution}_Y^2}$$

To select a lens, you can use the following formula:

$$\text{Focal Length} = FL = \frac{WD}{1 + \frac{FoW}{S}} \text{ (distances in millimeters)}$$

Alternatively, if you already have a lens, you can compute working distance using the following formula:

$$\text{Working Distance} = WD = FL \times \left(1 + \frac{FoW}{S}\right) \text{ (distances in millimeters)}$$

### **Examples:**

- PixelSize = 0.008mm
- Full resolution 1696 x 1708
- FoW = Object size = 100 mm
- WD = 300 mm

$$S = 0,008 \times \sqrt{1696^2 + 1708^2} = 19,26 \text{ mm}$$

$$FL = \frac{300}{1 + \frac{100}{19,26}} \sim 48,5 \text{ mm}$$

⇒ Selected focal length = 50 mm.

Same example but using a 35mm lens.

$$WD = 35 \times \left(1 + \frac{100}{19,26}\right) \sim 217 \text{ mm}$$

⇒ Object must be set at least at WD = 217 mm.

### 3 Camera Overview

#### 3.1 Model Description

##### 3.1.1 Model Name and Options

CamPerform camera series decoding information are illustrated here after. Check camera label on the bottom side to get both:

- Ref.: Camera Model Name (see Figure 3)
- S/N.: Camera Serial Number (see Figure 4)

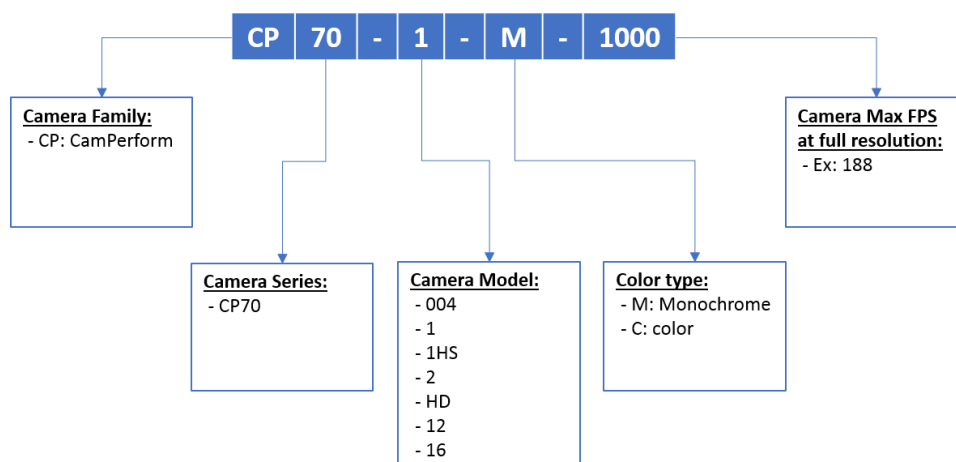

Figure 3: Camera Model Name Decoder

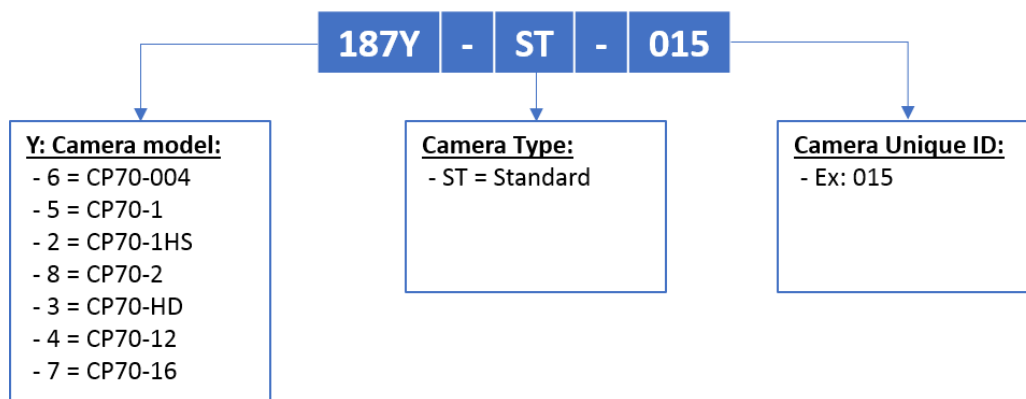

Figure 4: Camera Serial Number Decoder

## 3.2 Technical Data

### 3.2.1 General Info

Feature	Comments
Power Source	External power supply or Power over CoaXPress (PoCXP): + 24V +/- 5% DC < 200mV ripple
Sensor resolution	4080 x 3072
Frame rate @ max. sensor res	188 fps
Image sensor	CMV12000 Global Shutter CMOS
Exposure Time	30 $\mu$ s - 1/Framerate
Active Area	22.44 mm x 16.90 mm
Sensor Diagonal Dimension	28.09 mm
Pixel Size	5.5 $\mu$ m
A/D Conversion	10Bit, 8 Bit
Dynamic	60 dB
Sensitivity	4.64 V/lux*s @525 nm
Saturation capacity (FWC)	12300 e-
SNR	40.9 dB
DSNU1288	160 e-
PRNU1288	1.3%
Non-linearity error	< 0.5%
Shutter efficiency	global electronic shutter
Trigger signal	TTL, 3.3 - 5 V, 10 mA, optically isolated
Trigger modes	internal free-run, external, CXP
Video Interface	CoaxPress CXP6, CXP5, CXP3 – 4 links
Uplink	Over CoaxPress
Mounting Screws	4 x M4 (depth 6mm) in front 4 x M2.5 (depth 5mm) at camera rear 2 x M4 (depth 6mm) on each 4 sides (8 in total) 1 x ¼ - 20 UNC (depth 6mm) on center of each 4 sides (4 in total)
Power consumption	Approximately 8.5 Watt
CoaxPress connectors	CoaxPress 4 x 1.0/2.3 DIN
Size	85 mm x 85 mm x 49 (without mount)
Weight	Approximately 400g without lens and mount

### 3.2.2 Spectral Response

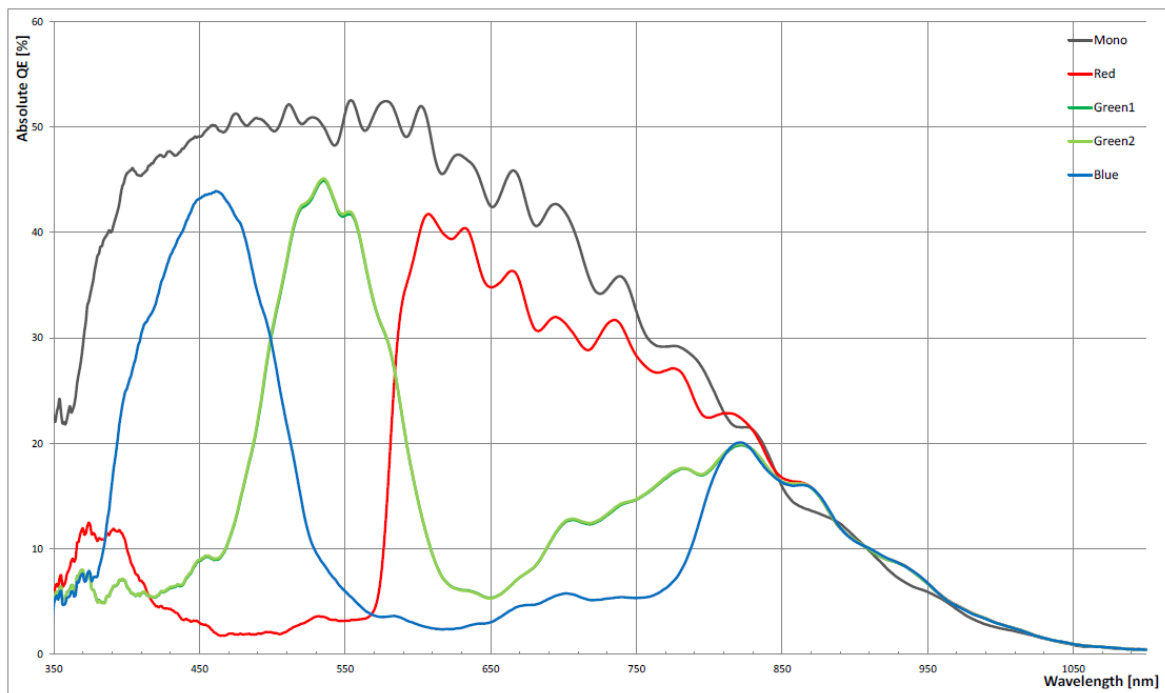

Figure 5: Camera Spectral Response

### 3.2.3 Glass Filter

Color cameras (CP70-12-C-188 model) are delivered with an IR filter placed in front of the sensor. Its typical transmittance is illustrated on Figure 6.

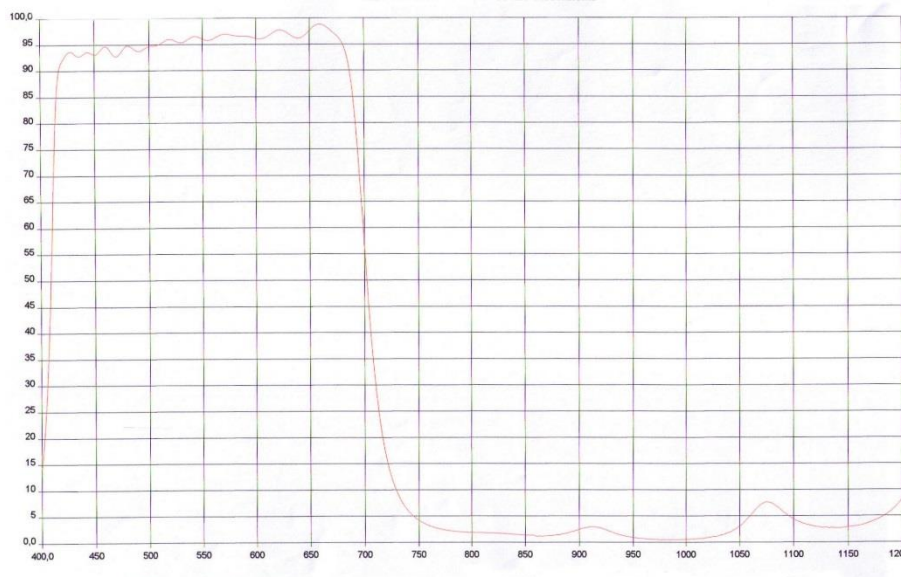

Figure 6: Glass Filter typical transmittance (1830-SS-10 IR Filter)

3.2.4 Mechanical Drawings - Dimensions and Mounting Points

3.2.4.1 *CP70 Mechanical Dimensions (with F-Mount - /FM option)*

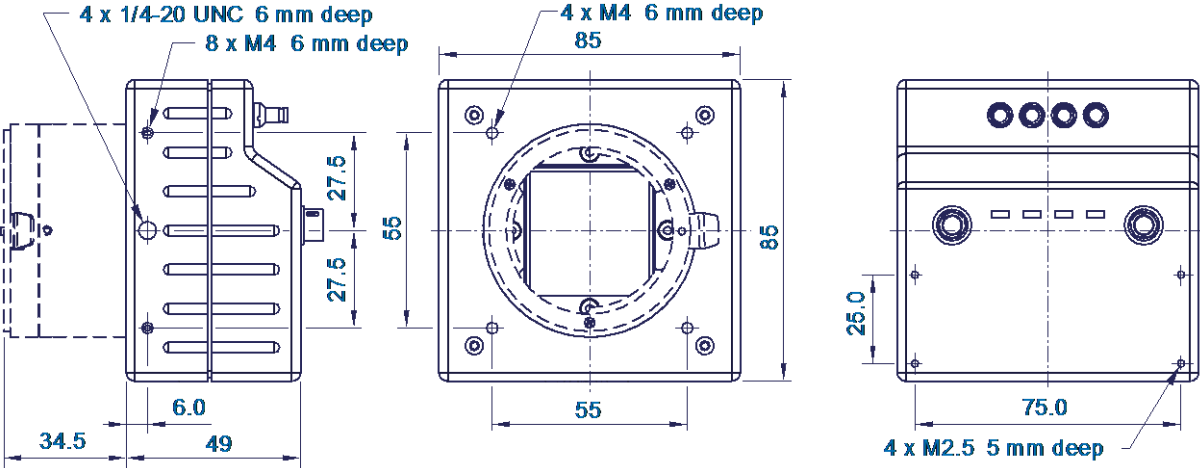

Figure 7: CP70 Dimensions (with F-Mount option)

## 4 Camera Main Features

---

This paragraph describes camera main features and how they can be used. It focuses on principles and overall understanding of these features. The camera control interface and specific values used to access these features are detailed in later paragraph "[6.2. XML Main Entries - Features Description, page 32](#)".

As explained later, these features are controlled by an XML file divided in "entries". *XML entries* are using this special text font for better identification in this paragraph.

Please check also "[6.2. XML Main Entries - Features Description, page 32](#)" paragraph to have a precise description of allowed values for each entry.

### 4.1 Frame Format

#### 4.1.1 Supported Pixel Formats

The camera supports the following pixel formats:

- Mono 8
- Bayer GB8 (Color cameras only)
- Mono10\_CXP1\_0 (used only for retro compatibility)
- Mono 10
- Bayer GB10 (Color cameras only)

Pixel format is controlled by XML entry:

- *PixelFormat*

#### 4.1.2 Single ROI

The full frame resolution of the camera is:

- 4080 x 3072

The resolution can be reduced in both directions. Resolution is controlled by XML entries:

- *Width / WidthMax*
- *Height / HeightMax*

When reducing the resolution, the ROI is centered in both directions by default. ROI position is controlled by XML entries:

- *OffsetX*
- *OffsetY*

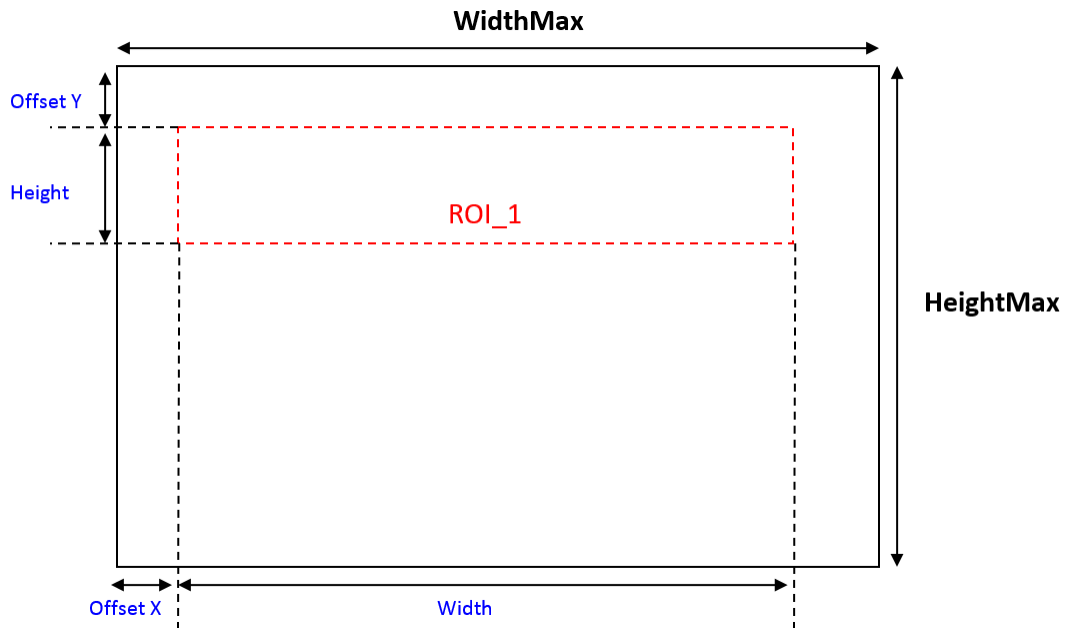

Figure 8: Camera Single ROI control

### 4.1.3 Dual ROI

#### 4.1.3.1 Dual ROI control

Dual ROI mode is controlled by XML entries:

- *Disable\_DUAL\_ROI*
- *Width / OffsetX*
- *YStart\_1 / YSize\_1*
- *YStart\_2 / YSize\_2*
- *Height = YSize\_1 + YSize\_2, must be updated manually after setting YSize\_1 and YSize\_2.*

The figure here after (Figure 9) shows how to use these entries.

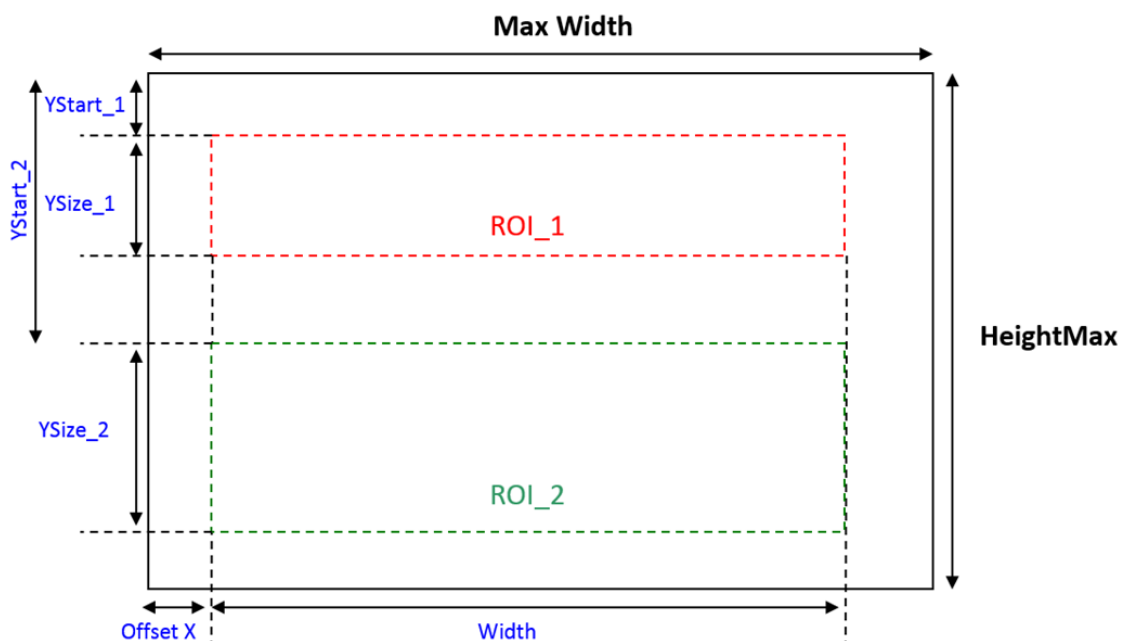

Figure 9: Camera Dual ROI control



### 4.1.3.2 Enabling and Configuring dual ROI

To enable and use dual ROI:

- Stop Acquisition
- Set *Width / OffsetX* according your needs. Both ROI share the same *Width / OffsetX*.
- Set *Disable\_DUAL\_ROI* to “Off”
- Set ROIs parameters *YStart\_1/ YSize\_1* and *YStart\_2/ YSize\_2* following these rules
  - ⇒  $(\text{Width} + \text{Offset X}) \leq \text{WidthMax}$
  - ⇒  $(\text{YStart}_1 + \text{YSize}_1) < \text{YStart}_2$
  - ⇒  $(\text{YStart}_1 + \text{YSize}_1) + (\text{YStart}_2 + \text{YSize}_2) \leq \text{HeightMax}$
- Set *Height = YSize\_1 + YSize\_2*

### 4.1.3.3 Dual ROI output Image

When using the Dual ROI mode, the output image send to the Frame Grabber is one image composed by the 2 ROIs with:

Output width = *Width*.

Output height = *Height = YSize\_1 + YSize\_2*.

It is up to Frame Grabber application to separate ROIs according dual ROI parameters.

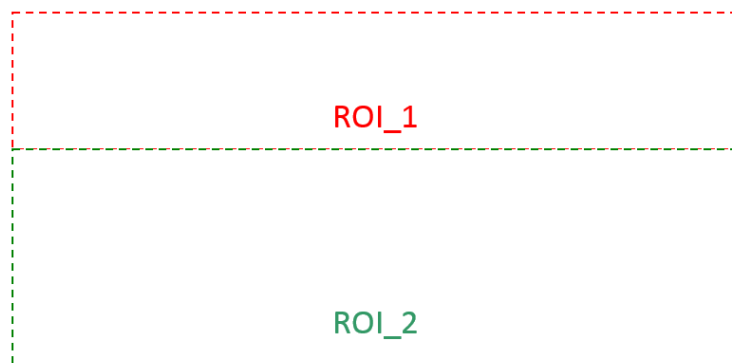

**Figure 10: Camera output image when using dual ROI**

### 4.1.3.4 Disabling dual ROI

To disable dual ROI, set *Disable\_DUAL\_ROI* entry to “On”, it will reset to ‘0’ dual ROI parameters. Then the camera is set to single ROI and is controlled as explained in previous paragraph [4.1.2 Single ROI](#).

## 4.2 Available CXP Configurations

The CoaXPress standard allows a lot of different configurations (number of cables, transfer rates, ...). You may want to change it to fit your system needs.

This camera is compatible with:

- CXP3\_X4 = 4 links at 3.125Gbps
- CXP5\_X4 = 4 links at 5Gbps
- **CXP6\_X4 = 4 links at 6Gbps (default configuration)**

CXP configuration is controlled by XML entry:

- [ConnectionConfig](#)



Using a lower transfer rate allows longer cable length.

## 4.3 Acquisition Control - Frame Generation and Synchronization

The camera frame acquisition is controlled by using camera XML AcquisitionStart and AcquisitionStop commands.

The camera frame acquisition can be synchronized by 3 different ways:

- **Camera Internal Generator:** (*AcquisitionMode* = "Continuous")  
 In this mode, the camera uses its own sync generator and generates frames continuously when acquisition is started. Frames are generated according to *AcquisitionFrameRate* value.  
 Please check next paragraph "[4.5. Frame Rate and Exposure, page 19](#)" for more information about frame rate and exposure control.
- **External Synchronization Generator:** (*AcquisitionMode* = "Single Frame")  
 In this mode, the camera uses an external signal to generate frames. You must apply a TTL signal the Sync In input of the camera. Please respect signal limits (current and voltage) and use the Aux. to BNC adapter or respect Aux. connector pinout (Hardware information in "[5.1.4. Auxiliary Connector, page 27](#)" paragraph).  
 Please check next paragraph "[4.5. Frame Rate and Exposure, page 19](#)" for more information about frame rate and exposure control.
- **Synchronization over CoaXPress by Frame Grabber:** (*AcquisitionMode* = "CoaxPress")  
 CoaXPress standard allows Frame Grabber synchronizing camera frame generation using specific packets called *trigger packets* sent on "CoaXPress uplink".  
 The frame grabber sends 2 kind of trigger packets: rising edge and falling edge trigger packets. It allows the camera to build a square synchronization signal:
  - Its period is the period of the rising edge trigger packets.
  - Its pulse width is the time difference between falling edge trigger packets and rising edge trigger packets.
 So, it is very similar as using an external generator but controlled by user acquisition system (usually a PC + a CoaXPress frame grabber).  
 Please check next paragraph "[4.5. Frame Rate and Exposure, page 19](#)" for more information about frame rate and exposure control.



Please check your Frame Grabber manual to use its trigger over CoaXPress mode.

Acquisition is controlled by XML entries:

- *AcquisitionStart*
- *AcquisitionStop*
- *AcquisitionMode*

## 4.4 TriggerActivation

When using CoaXPress or External synchronization modes, this entry select selects the edge of the trigger signal use for image synchronization.

Supported values are:

- RisingEdge
- FallingEdge

The TriggerActivation is controlled by XML entry:

- *TriggerActivation*

## 4.5 Frame Rate and Exposure

- **Camera Internal generator:** (*AcquisitionMode* = “Continuous”)
  - Frame rate: In this mode, frame rate is defined by camera register and can be modified using camera XML control interface.
  - Exposure: In this mode, the exposure is defined by camera register and can be modified using camera XML control interface.
- **External Synchronization generator:** (*AcquisitionMode* = “Single Frame”)
  - Frame rate: In this mode, the frame rate is defined by the external TTL signal period. The allowed frame rate range is the same as in Internal Synchronization.
  - Exposure: In this mode, the exposure can be controlled by 2 different sources. The XML “Granularity” feature allows you to select the control source:
    - *Granularity* = “On”: Same as in the “Continuous” mode, camera register controls the exposure and can be modified using camera XML control interface.
    - *Granularity* = “Off”: The exposure is controlled by the external TTL signal pulse width.
- **Synchronization over CoaXPress by Frame Grabber:** (*AcquisitionMode* = “CoaxPress”)
  - Frame rate: In this mode, the frame rate is defined by Frame Grabber “Trigger packets” period. The allowed frame rate range is the same as in Internal Synchronization.
  - Exposure: In this mode, the exposure can be controlled by 2 different sources. The XML *Granularity* feature allows you to select the control source:
    - *Granularity* = “On”: Same as in the “Continuous” mode, camera register controls the exposure and can be modified using camera XML control interface.
    - *Granularity* = “Off”: The exposure is controlled by the CoaXPress TTL signal pulse width.

Frame rate and exposure are controlled by XML entries:

- *AcquisitionFrameRate*
- *ExposureTime*
- *Granularity*

## 4.5.1 Synchronization timings

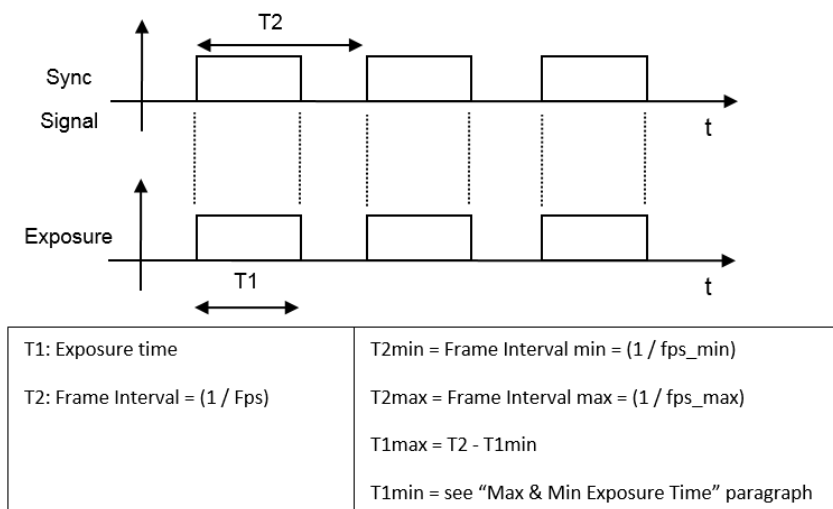

Figure 11: Sync Timings

### 4.5.1.1 @ Internal Synchronization

Timings are controlled by camera. Using XML interface range ensures that timings are respected.

### 4.5.1.2 @ External Synchronization

- If *Granularity* is enabled ("On"):
    - T2 is controlled by user external generator signal period
    - T1 is controlled by camera
  - If *Granularity* is disabled ("Off"):
    - T2 is controlled by user external generator signal period
    - T1 is controlled by user external generator pulse width
- In both cases, timings must be respected.

### 4.5.1.3 @Synchronization over CoaXPress

- If *Granularity* is enabled ("On"):
    - T2 is controlled by CoaXPress frame grabber "signal" period
    - T1 is controlled by camera
  - If *Granularity* is disabled ("Off"):
    - T2 is controlled by CoaXPress frame grabber "signal" period
    - T1 is controlled by CoaXPress frame grabber "signal" pulse width
- In both cases, timings must be respected.

## 4.5.2 Max & Min FPS

Camera maximum FPS can be reached at default CoaXPress configuration. If you reduce CoaXPress speed (ex: CXP6 to CXP5 or CXP3), the maximum FPS is reduced.

**$Max_{FPS}$**  = A frame rate calculator will be soon online on our Website.

You can contact Optronis support to get a Windows version of this frame rate calculator.

**$Min_{FPS} = 20$**

**Maximum Frame Rate Examples (at default CoaXPress configuration):**

<u>PixelResolution_X</u>	<u>PixelResolution_Y</u>	<u>Max Frame rate</u>
4080	3072	188
4080	2160	267
3840	3072	188
3840	2160	267
1920	1080	527
1920	1024	555
512	512	1077
256	256	2035
...	...	...
256	8	14652

## 4.5.3 Max & Min Exposure Time

The maximum exposure time depends on current frame rate and can be calculated using this formula:

**$Min_{Exposure} = 30\mu s$**

$$Max_{Exposure} = \frac{1}{Framerate} - Min_{Exposure}$$

## 4.6 Sync Out Output

The camera output Sync Out delivers a TTL signal reflecting camera frame acquisition. External synchronization may be operated in level detection mode. Please see the external synchronization timing for more information about resulting frame rates and exposure times.

The Sync Out output can be used to synchronize other devices as e.g. additional cameras or external light flashes.

Using camera accessory “Pigtail cable” (BNC adapter) is the easiest way to use Sync Out signal.

Note that:

- Sync Out signal period is the real effective frame delivered by the camera.
- Sync Out signal high time is the effective exposure time done by the camera.

## 4.7 Image Enhancement

### 4.7.1 Hot Pixels Correction

A hot pixel correction is done during camera production. Up to 768 “hot pixels” can be corrected. This correction is enabled by default (“**On**”) and can be disabled (“**Off**”) to display raw pixels.

HotPixelCorrection is controlled by XML entry:

- *HotPixelCorrection*

### 4.7.2 Gain

An analog gain can be applied in case of low luminosity for example.

Gain is controlled by XML entry:

- *Gain*

Supported values are “x1”, “x2” and “x3”.

## 4.8 Counter Information

An optional counter information can be enabled.

When enabled (“**Yes**”), this counter information is integrated in the first pixels of every transferred frame and replace the first 40 bits (i.e. 5 pixels in Mono8 pixel format). This 40bit counter is built as follow:

- 16 first bits contain an image counter (incrementing with every frame transferred)
- 24 next bits contain a micro-second precision counter that indicates the time when the frame exposure has started.

When disabled (“**No**”), no information is integrated in the transferred frames and all bits are pixel data.

Counter Information is controlled by XML entry:

- *AddCounterInformation*

## 4.9 Multi Slope (HDR) mode

### 4.9.1 Multi Slope Parameters

The camera has the possibility to achieve a high optical dynamic range by using a multiple slope feature. This feature will partially reset those pixels which reach a programmable voltage, while leaving the other pixels untouched. This can be done 2 times within one exposure time to achieve a maximum of 3 exposure slopes.

Multi-Slope mode is controlled by XML entries:

- *NumberSlopes*
- *ExpKp1*
- *ExpKp2*
- *Vtfl1*
- *Vtfl2*

## 4.9.2 Multi Slope Principle

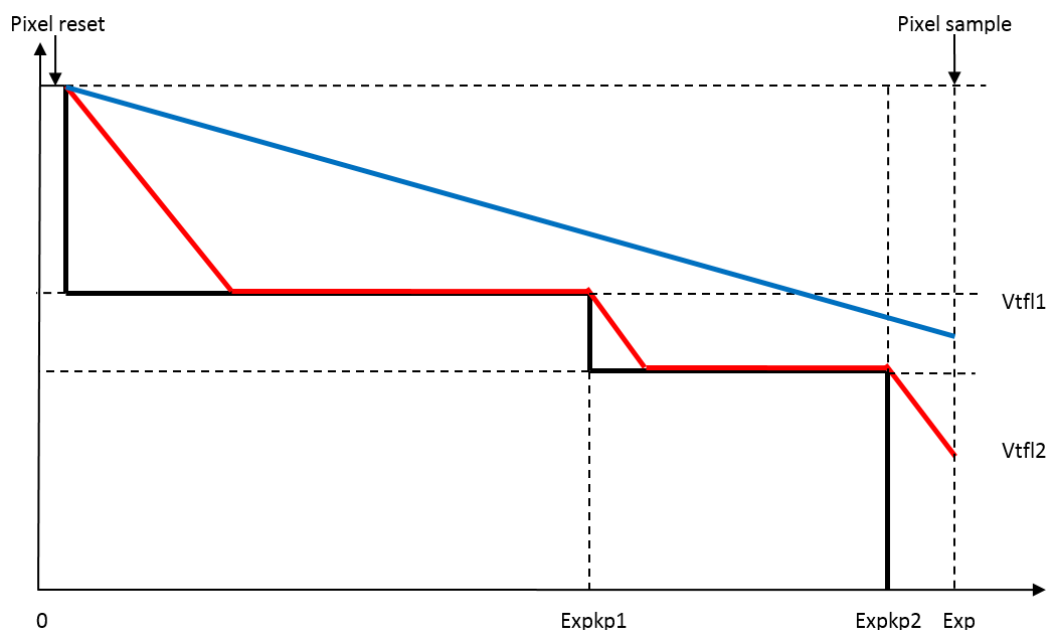

Figure 12: Multi-Slope control

In the figure above, the red lines represent a pixel on which a large amount of light is falling. The blue line represents a pixel on which less light is falling. As shown in the figure, the bright pixel (red) is held to a programmable voltage for a programmable time during the exposure time. This happens two times to make sure that at the end of the exposure time the pixel is not saturated. The darker pixel (blue) is not influenced by this multiple slope and will have a normal response. The  $V_{tfl1}$  voltages and different exposure times are programmable. Using this feature, a response as detailed in the figure below can be achieved. The placement of the kneepoints in X is controlled by the  $V_{tfl}$  programming, while the slope of the segments is controlled by the programmed exposure times.

Default values of  $Expkp1$  and  $Expkp2$  are 50% and 70% of the total exposure time.  $V_{tfl1}$  is set to 45 and  $V_{tfl2}$  is set to 55 (corresponding to the figure above).  $V_{tfl1}$  corresponds to  $Expkp1$ ,  $V_{tfl2}$  corresponds to  $Expkp2$ .

- $NumberSlopes$  range 1 to 3
- $V_{tfl1}$  and  $V_{tfl2}$  range: 0 to 63 (0 equals 0% level, 63 equals 100%level).
- $Expkp1$  and  $Expkp2$  range 1 to 100 (1 equals 1%, 100 equals 100%).

## 4.9.3 Multi-Slope Example

It is suggested to operate as follow:

- Select single slope ( $NumberSlopes = 1$ ) and look to image (oversaturated)
- Select double slope ( $NumberSlopes = 2$ ) and check with adapting  $V_{tfl1}$  if dark regions keep clearly visible.
- Increase  $Expkp1$  until oversaturated regions become visible. Go from 1 to maximum range.
- If still oversaturation, then go to triple slope ( $NumberSlopes = 3$ ) and check with adapting  $V_{tfl2}$  if some former oversaturated regions keep visible.
- Increase  $Expkp2$  from 1 to maximum range to adjust visibility further.

## 4.10 Save User Configuration to Flash

Camera can boot using a specific user configuration stored in its flash memory. At power up, the camera uses any user configuration previously saved. If no user configuration is there, the camera boots using the default factory configuration.

User configuration can be saved by calling command “SaveToFlashWithRebootAndWithoutAutoStart”.

A second command “SaveToFlashWithRebootAndWithAutoStart” save user configuration but also force live/acquisition start without requiring any frame grabber command. Beware that if frame grabber sends Connection Reset command (Default CXP behavior), the stream will be stopped and this “AutoStart” feature won’t be used.

To boot with default camera configuration, user configuration must be deleted by calling XML command “FactoryFlash”.

User configuration in camera flash is controlled by XML entries:

- *SaveToFlashWithRebootAndWithAutoStart*
- *SaveToFlashWithRebootAndWithoutAutoStart*
- *FactoryFlash*



## 5 Camera Hardware Interface

### 5.1 Connectors and LED

#### 5.1.1 Identify Connectors and LED Positions

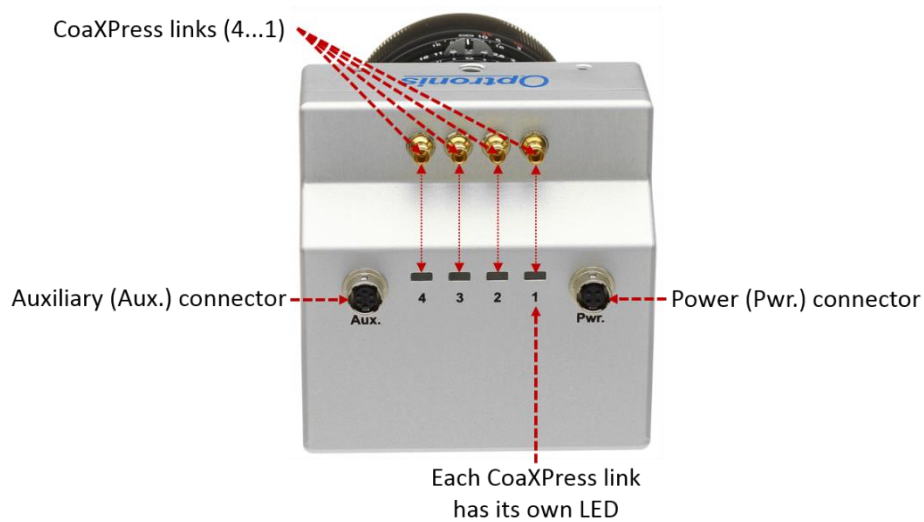

**Figure 13: CP70 HW Identification**

#### 5.1.2 Powering Camera

Camera can be powered either by Power over Coaxpress (PoCXP) or using its external power connector.

##### 5.1.2.1 *Using PoCXP*

When using PoCXP, the power is supplied by the Frame Grabber through CXP cable on cable n°1. Other cables are used only for data transfer.

Please refer to your Frame Grabber documentation for more information.

### 5.1.2.2 External Power Supply

Power connector is used to power camera when using an external power supply instead of power over CoaXPress feature (PoCXP).

The connector is labelled “Pwr” for CP70.

Optronis Camera accessory “Power supply” is recommended when using an external power supply. Alternatively, your power supply must respect bellow characteristics:

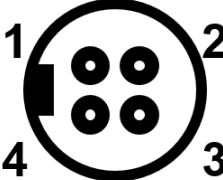
<b>CP70 Series</b>	
Connector info: Camera (P) connector type: <ul style="list-style-type: none"> <li>• <b>Hirose HR10A-7R-4S</b></li> </ul> Cable Connector: <ul style="list-style-type: none"> <li>• <b>Hirose HR10A-7P-4P</b></li> </ul>	
Connector View: <div style="text-align: center;">  </div> <p style="text-align: center;"><small>Figure 14: CP70 Power Connector</small></p>	
Connector Pinout:	
<b>Pin 1, 2: VCC</b>	+24Volt +/-5% (Ripple < 200mV) Inrush Current ~0,6A
<b>Pin 3, 4: GND</b>	Power Ground

### 5.1.3 CoaXPress Connectors

<b>CP70 Series</b>	
Connector info: 4 x 75 Ω 1.0/2.3 DIN connector. Compliant with IEC 61169-29, as required by CoaXPress specification.	
Remark: Connectors are labelled from 1 to 4	

## 5.1.4 Auxiliary Connector

Auxiliary connector is used to access camera Sync In and Sync Out IOs and for firmware updates.

The connector is labelled “Aux” for CP70.

Camera accessory “Pigtail cable” gives user 2 x 50-ohm BNC connectors to access Sync IN and Sync Out signals.

Camera accessory “Programming cable” allows an USB connection to a PC for firmware updates.

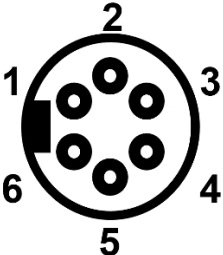
CP70 Series	
Connector info: Camera (A) connector type: <ul style="list-style-type: none"> <li>• <b>Hirose HR10A-7R-6S</b></li> </ul> Cable Connector: <ul style="list-style-type: none"> <li>• <b>Hirose HR10A-7P-6P</b></li> </ul>	
Connector View: 	
<small>Figure 15: CP70 Auxiliary Connector</small>	
Connector Pinout:	
<b>Pin 1: Sync IN</b>	External Synchronization Input. TTL level: < 0,8 Volt (low) > 2 Volt (high)
<b>Pin 2: Reserved</b>	
<b>Pin 3: Sync Out</b>	External Synchronization Output. TTL level @ high impedance, 0 to 2 Volt @ 50 Ohm.
<b>Pin 4,5,6: GND</b>	Ground

### 5.1.4.1 Sync In

The Sync In camera input is TTL adapted (high impedance). To adapt to 50 Ohm, please add an external 50 Ohm termination. The input principle is described by Figure 16.

To operate Sync In correctly, a Sync In driver has to be used with a minimum sink current (TTL low level) of 5mA.

Source Current (TTL High Level) of the Sync In Driver is negligible (0mA)



Sync In input voltage limits are: [-5V ⇔ +30V].  
Voltages beyond these limits may damage camera.

Easiest driver circuit is a transistor working in open collector configuration.

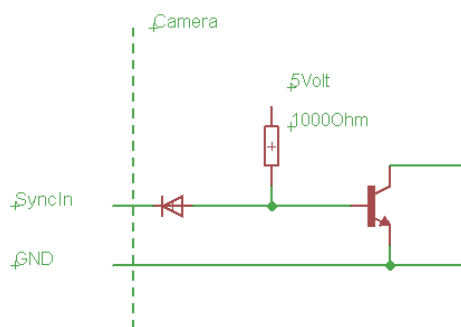

Figure 16: Sync In Input Schematics

### 5.1.4.2 Sync Out

Sync Out has a built in 50 Ohm driver. The output principle is described by Figure 17.

At 50 Ohm termination, the driver voltage is between 0 (low level) to ≈2 Volts (high level).

At high impedance termination, the driver voltage is in between 0 (low level) to ~4 Volts (high level).

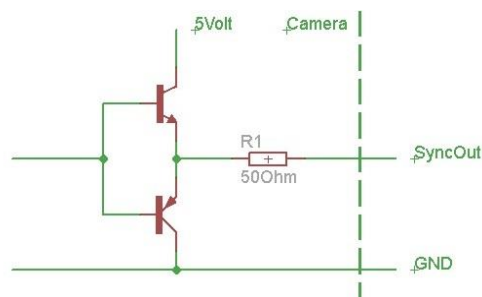

Figure 17: Sync Out Output Schematics

## 5.1.5 CoaXPress Status LEDs

LED colors and states are defined by CoaXPress standard. The table here after is listed all possibilities.

Camera LEDs Colors	Camera LED States
Red	Off
Orange	Solid
Green	Fast Flash 12.5Hz (20ms on, 60ms off)
	Slow Flash 0.5Hz (1s on, 1s off)
	Slow pulse 1Hz (200ms on, 800ms off)

Each 4 CoaXPress links / connector has its dedicated LED indicating its status. The table here after describes camera link status for every possible LED state.

Camera Link State	LED state
No power	Off
System booting	Solid orange or Led Chaser
Powered, but nothing connected (only for power over power connector)	Slow pulse red
Link detection in progress, PoCXP active	Fast flash green
Link detection in progress, PoCXP not in use	Fast flash orange
Camera / Grabber incompatible, PoCXP active	Slow flash alternate red / green
Camera / Grabber incompatible, PoCXP not in use	Slow flash alternate red / orange
Camera connected, but no data being transferred	Slow pulse green
Camera connected, waiting for event (e.g. trigger, exposure pulse)	Slow pulse orange
Camera connected, transferring frames	Solid green
Error during data transfer	500ms red pulse
System error	Fast flash red
Firmware Update	Solid red

## 6 Camera Control Interface

---

### 6.1 GenICam XML Interface

#### 6.1.1 CoaXPress GenICam Compliant Interface

The camera control is based on camera registers accesses (read and/or write). Some of these registers are defined by CoaXPress standard and others are Optronis specific and are used to controlled camera specific features.

The camera firmware contains a GenICam / CoaXPress compliant XML file which gives access to all required camera registers and thus allows a simplified control of the camera by any CoaXPress compliant Frame Grabber.

This XML file consists in entries. Each of these entries correspond to a camera feature and use its own access type, values, ranges, etc... Paragraphs here after are explaining more in details how to use this XML file.

#### 6.1.2 XML Entry Access Mode

Each XML entry have a specific access mode:

- RO: Read Only  
This entry can be only read, any write access will be ignored.
- RW: Read and Write  
This entry can be read and write.
- WO: Write Only  
This entry is supposed to be write only.

#### 6.1.3 XML Entry Types Description

Each XML entry use a specific type of data.

- String
- Integer
- Float
- Command: (for example, AcquisitionStart() or AcquisitionStop())
- Enumeration: list of allowed value. (for example, "On", "Off")
- IntSwissKnife: A formula computing an Integer using some other XML entries.

#### 6.1.4 XML Entry Allowed Values

Some XML entries have a limited range of possible values depending on their type.

### 6.1.4.1 Numbers (Integer, Float, ...)

For numbers (integer, float, etc...), limits are defined by:

- All these entries consist in a 4bytes register access.
- Masked = If a bit mask must be applied when accessing this value
- Min = Minimum possible value
- Max = Maximum possible value
- Inc = Increment

A value X is defined by formula  $X = MinValue + N \times Inc$   
 This value must respect  $Min \leq X \leq Max$

### 6.1.4.2 Strings

For Strings, the limit is the length “L” (number of characters).

### 6.1.4.3 Command

A command consists in writing a fixed value = command value “CV” in a camera register. All these entries consist in a 4bytes register access.

### 6.1.4.4 Enumeration

XML gives a list of values. Only listed values are valid. All these entries consist in a 4bytes register access.

## 6.1.5 XML Masked Values

Some XML entries are sharing the same camera registers and use bit masking to access the dedicated bits.

These entries use XML parameters “LSB” and “MSB” to identify the right bits.

#### **Example:**

If an XML entry has “Mask: LSB:31-MSB:16”, it means that the you access a 4bytes/32bit register and only the upper 16 bits are used by this entry.

## 6.1.6 Acquisition/Live Stop Required

Some XML features require to stop image acquisition to be modified. Please be careful and stop camera image acquisition when it is required.

In XML entries description paragraph, such entries are greyed out as shown in above example to ease their identification.

#### **Example of greyed out XML entry:**

Width @ 0x6000	RW	Integer	Min: 128 Max: WidthMax Inc: 128	This feature represents the actual image width expelled by the camera (in pixels).
-------------------	----	---------	---------------------------------------	--



If you modify a feature requiring acquisition to be stopped without stopping acquisition, camera behavior may become unstable and a power cycle may be required.

## 6.2 XML Main Entries - Features Description

Main XML entries are described in below tables. For more information and full XML content, you can retrieve full camera full XML file using your frame grabber XML tools.

Xml entry Name Address	Access Mode	Type	Valid Values	Description
<i>DeviceControl category</i>				
DeviceVendorName @ 0x2000	RO	String	L = 32	Name of the manufacturer of the device.
DeviceModelName @ 0x2020	RO	String	L = 32	This feature provides the model of the device.
DeviceFirmwareVersion @ 0x2090	RO	String	L = 32	Version of the firmware in the device.
DeviceID @ 0x6028	RO	String	L = 16	This feature stores a camera identifier.
<i>ImageFormatControl category</i>				
WidthMax @ 0x6000	RO	Integer	Mask: LSB:15-MSB:0	Maximum width (in pixels) of the image. The dimension is calculated after horizontal binning, decimation or any other function changing the horizontal dimension of the image.
HeightMax @ 0x6004	RO	Integer	Mask: LSB:15-MSB:0	Maximum height (in pixels) of the image. This dimension is calculated after vertical binning, decimation or any other function changing the vertical dimension of the image.
Width @ 0x6000	RW	Integer	Mask: LSB:31 - MSB:16 Min: 256 Max: WidthMax Inc: 16	This feature represents the actual image width expelled by the camera (in pixels).
Height @ 0x6004	RW	Integer	Mask: LSB:31-MSB:16 Min: 8 Max: HeightMax Inc: 8	This feature represents the actual image height expelled by the camera (in pixels).
OffsetX @ 0x60D0	RW	Integer	Min: 0 Max: OffsetXMax Inc: 32	Horizontal offset from the origin to the area of interest (in pixels).
OffsetY @ 0x60D4	RW	Integer	Min: 0 Max: OffsetYMax Inc: 8	Vertical offset from the origin to the area of interest (in pixels).
PixelFormat @ 0x60F0	RW	Enumeration	List: "Mono8" "Mono10_CXP1_0" "Mono10" "BayerGB8" "BayerGB10"	This feature indicates the format of the pixel to use during the acquisition.



Xml entry Name Address	Access Mode	Type	Valid Values	Description
<b>AcquisitionControl category</b>				
AcquisitionMode @ 0x6018	RW	Enumeration	List: "Continuous" "SingleFrame" "CoaxPress"	This feature controls the acquisition mode of the device. <ul style="list-style-type: none"> <li>• Continuous: Camera internal trig</li> <li>• SingleFrame: Camera ext. IO trig</li> <li>• CoaxPress: trig over CXP</li> </ul>
TriggerActivation @ 0x614C	RW	Enumeration	List: "RisingEdge" "FallingEdge"	This feature control which edge of the trigger signal is used for image sync, when AcquisitionMode = "SingleFrame" or "CoaxPress". This feature has no effect in "Continuous" mode.
AcquisitionStart @0x601C	RW	Command	CV = '1' Mask: LSB:31-MSB:24	This feature starts the Acquisition of the device.
AcquisitionStop @0x601C	RW	Command	CV = '0' Mask: LSB:31-MSB:24	This feature stops the Acquisition of the device at the end of the current Frame.
AcquisitionFrameRate @ 0x60C0	RW	Float	Min: 20 Max: dynamic, depends on other parameters Max available at address 0x60C4	Frame rate in Hz.
ExposureTime @0x60C8	RW	Float	Min: 30 Max: dynamic, depends on other parameters Max available at address 0x60CC	Sets the Exposure time (in microseconds) when ExposureMode is Timed. This controls the duration where the photosensitive cells are exposed to light.
Granularity @ 0x6018	RW	Enumeration	List: "On" "Off"	Granularity mode. If "On", the exposure is controlled by "ExposureTime" entry. If "Off", exposure is controlled by Sync In pulse width (External or CoaxPress trig modes only).
<b>TransportLayerControl category</b>				
PayloadSize	RO	IntSwissKnife		Provides the number of bytes transferred for each image or chunk on the stream channel. This includes any end-of-line, end-of-frame statistics or other stamp data. This is the total size of data payload for a data block.
<b>Support category</b>				
Standard @ 0x0000	RO	Integer		CXP Bootstrap register Standard.
Revision @ 0x0004	RO	Integer		CXP Bootstrap register Revision.

Xml entry Name Address	Access Mode	Type	Valid Values	Description
<b>CXP category</b>				
ConnectionReset @ 0x4000	RW	Integer		CXP Bootstrap register ConnectionReset.
DeviceConnectionID @ 0x4004	RO	Integer		CXP Bootstrap register DeviceConnectionID.
MasterHostConnectionID @ 0x4008	RO	Integer		CXP Bootstrap register MasterHostConnectionID.
ControlPacketDataSize @ 0x400C	RO	Integer		CXP Bootstrap register ControlPacketDataSize.
StreamPacketDataSize @ 0x4010	RW	Integer		CXP Bootstrap register StreamPacketDataSize.
ConnectionConfig @ 0x4014	RW	Enumeration	List: "CXP3_X4" "CXP5_X4" "CXP6_X4"	CXP Bootstrap register ConnectionConfig.
ConnectionConfigDefault @ 0x4018	RO	Integer		CXP Bootstrap register ConnectionConfigDefault.
TapGeometry	RO	Enumeration	List: "X1Y1"	TapGeometry
<b>Optronis category...</b>				
IndicatorLamps @ 0x601C	RW	Enumeration	List: "On" "Off" Mask: LSB:8-MSB:15	Switch ON/OFF indicator lamps.
AddCounterInformation @ 0x62DC	RW	Enumeration	List: "Yes" "no"	AddCounterInformation
HotPixelCorrection @ 0x6140	RW	Enumeration	List: "On" "Off"	Enable or disable hot pixels correction.
Gain @ 0x6160	RW	Enumeration	List: "x1" "x2" "x3"	Analog gain applied on every pixel.
ColorSensor @ 0x6038	RO	Integer	Min: 0 Max: 1 Inc: 1	Indicates if camera has camera a color sensor. '0' means mono sensor. '1' means color sensor.
Disable_DUAL_ROI @ 0x6110	RW	Enumeration	List: "On" "Off"	Disable dual ROI feature.
YStart_1 @ 0x6100	RW	Integer	Min: 0 Max: 3071 Inc: 8	This feature represents the actual ROI1 vertical start expelled by the camera (in pixels).
YSize_1 @ 0x6104	RW	Integer	Min: 8 Max: 3072 Inc: 8	This feature represents the actual ROI1 vertical height expelled by the camera (in pixels).
YStart_2 @ 0x6108	RW	Integer	Min: 0 Max: 3071 Inc: 8	This feature represents the actual ROI2 vertical start expelled by the camera (in pixels)
YSize_2 @ 0x610C	RW	Integer	Min: 8 Max: 3072 Inc: 8	This feature represents the actual ROI2 vertical height expelled by the camera (in pixels).

Xml entry Name Address	Access Mode	Type	Valid Values	Description
<i>...Optronis category</i>				
SaveToFlashWithRebootAndWithAutoStart @ 0x6024	RW	Command	CV= '0x0101'	Save current user configuration to flash. The camera will start with this setup and will start streaming after power up automatically. Beware that if frame grabber sends a Reset command (Default CXP behavior), the stream will be stopped this "AutoStart" feature won't be used.
SaveToFlashWithRebootAndWithoutAutoStart @ 0x6024	RW	Command	CV= '0x0001'	Save current user setup to flash. The camera will start with this setup.
FactoryFlash @ 0x6024	RW	Command	CV= '0x0000'	Reset any user setup saved in flash. The camera will boot in factory default configuration.
NumberSlopes @ 0x6164	RW	Integer	Min: 1 Max: 3 Inc: 1	Number of slopes.
ExpKp1 @ 0x6144	RW	Integer	Min: 1 Max: 100 Inc: 1	1 <sup>st</sup> multi slope exposure.
ExpKp2 @ 0x6148	RW	Integer	Min: 1 Max: 100 Inc: 1	2 <sup>nd</sup> multi slope exposure.
Vtfl1 @ 0x6168	RW	Integer	Min: 0 Max: 63 Inc: 1 Mask: LSB:31- MSB:26	1 <sup>st</sup> multi slope voltage.
Vtfl2 @ 0x6168	RW	Integer	Min: 0 Max: 63 Inc: 1 Mask: LSB:24- MSB:19	2 <sup>nd</sup> multi slope voltage.

## 7 Firmware Update

Camera firmware update is available through camera Aux connector by using the camera accessory “Programming cable”. This cable allows an USB connection to a PC and must be used together with Optronis Windows update software “UCXP\_flash.exe”.



Before updating camera firmware, please check product website page (download tab) to be sure that you have:

- The Last Firmware Version
- The Last Firmware Update Software Version (Setup\_UCXP\_Flash\_vx.y.z.exe)

Update process is described in “ReadMe.pdf” file generated when installing UCXP Flash.exe. Please check this file to get the last up to date firmware update process description. Default folder is:

*C:\Program Files (x86)\Optronis\UCXP\_Flash\_vx.x.x\Documentation\*

Please find below a quick description of the updating process:

- 1) If your software is out of date or if this is the first use:  
Execute last version of “Setup\_UCXP\_Flash\_vx.y.z.exe” to install Firmware Update Software and Programming cable Drivers.  
Restart computer.
- 2) Connect USB cable to PC and camera Aux input.  
Use PC rear USB ports as front ports are often not working.
- 3) Power cycle the camera.
- 4) Start UCXP\_Flash.exe
- 5) Select your camera series

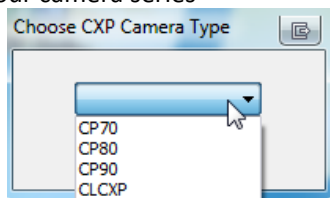

Figure 18: Camera Series Selection

- 6) When UCXP\_flash.exe is connected to the camera, camera LEDs become solid RED.  
Click on “Upload RBF” button and select the new firmware (.rbf file)

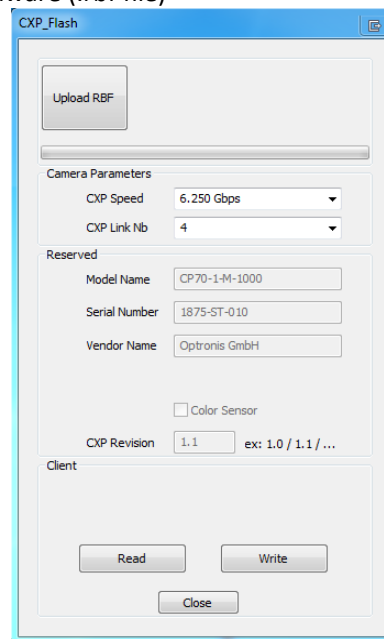

Figure 19: Software Interface

- 7) Wait end of process (10 to 20 minutes, depending on camera and firmware size)  
Power cycle camera when programming is finished.



If remaining time is higher than 20min, it often means that the cable is not well detected. Close software and end “UCXP\_flash” process if it is still running. Choose another USB port, power cycle camera and restart software.

## 8 Revisions

---

### 8.1 Manual Revision

Manual Revision	Date	Description
L	17/08/2018	<ul style="list-style-type: none"> <li>• Correct Power Connector pinout</li> </ul>
K	24/04/2018	<ul style="list-style-type: none"> <li>• Update several registers addresses after firmware modification (see firmware v13.0.6 release note in next table).</li> </ul>
J	03/04/2018	<ul style="list-style-type: none"> <li>• Update content</li> </ul>
I	29/01/2018	<ul style="list-style-type: none"> <li>• Update content</li> <li>• New presentation and layout</li> <li>• Synchronized content with datasheet v7/2016</li> </ul>

### 8.2 Firmware Revision

Firmware Revision	Date	Description
v13.0.6	24/04/2018	<ul style="list-style-type: none"> <li>• Minor corrections</li> <li>• Improve stability when modifying CoaXPress speed or topology</li> <li>• <b>Modify several register addresses.</b> New addresses are: <ul style="list-style-type: none"> <li>- AddCounterInformation: @ 0x62DC</li> <li>- Gain: @ 0x6160</li> <li>- NumberSlopes: @ 0x6164</li> <li>- Vtfl1: @ 0x6168</li> <li>- Vtfl2: @ 0x6168</li> </ul> </li> </ul>
v13.0.5	18/01/2018	<ul style="list-style-type: none"> <li>• Minor corrections</li> <li>• Add Trigger Activation feature (rising or falling edge)</li> </ul>
V13.0.3	20/10/2017	<ul style="list-style-type: none"> <li>• Minor corrections</li> </ul>